

KOMATSU PW160-7
Max Capacity Contours of Radius(m) Plots 2.1m Dipper
Gradient 1 in -25 Height 2m Lift BP
Unlocked Rail Cant -150mm

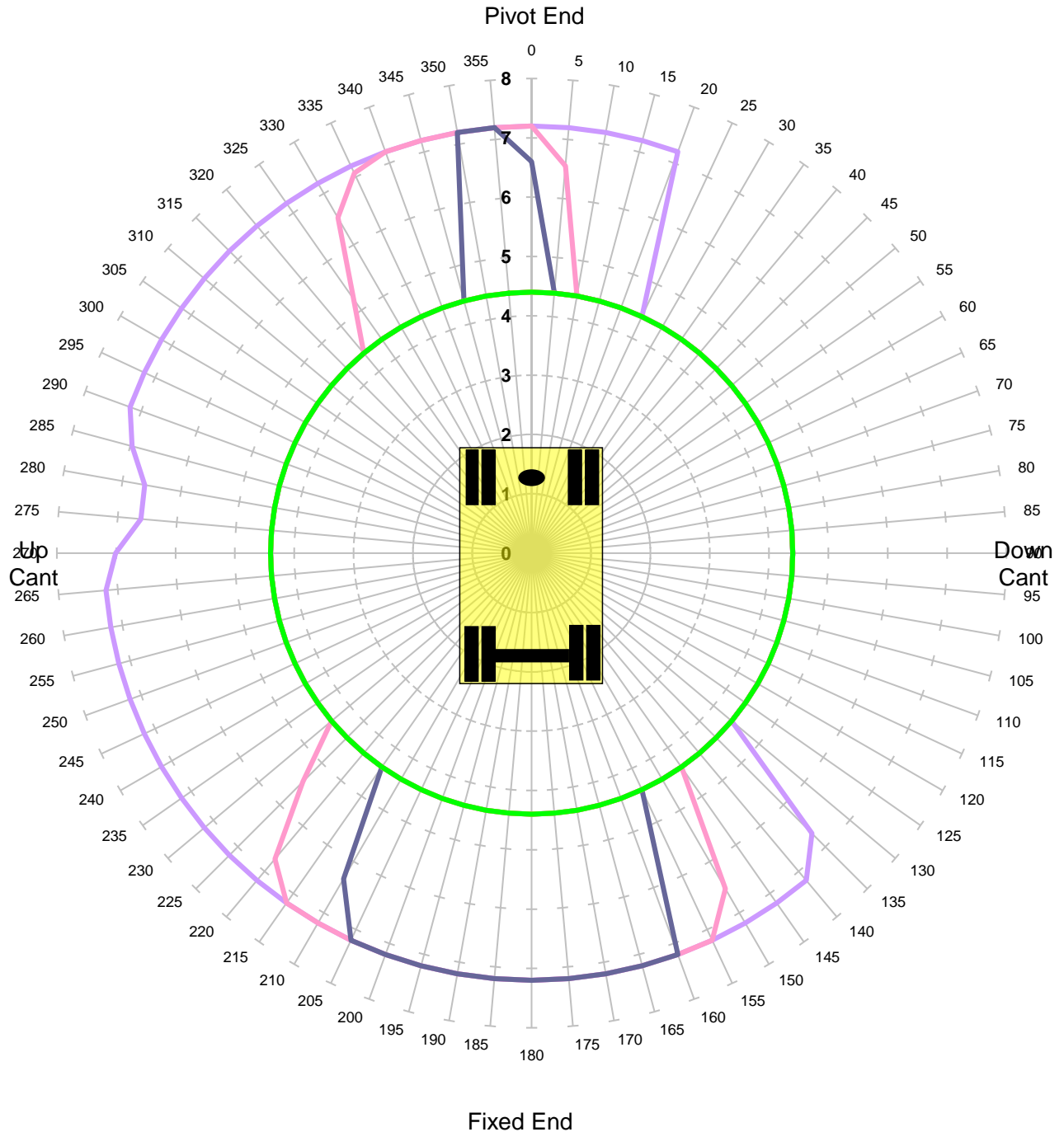

Units in Tonnes

- 1
 — 2
 — 3
 — 4
 — 5
 — 6
 — 7

MACHINE & MODEL:	KOMATSU PW160-7	REFERENCE:	REXQUOTE
SERIAL No:	2325	DATE OF CHART:	7-Feb-2022
EQUIPMENT:	5.15m+2.1m	SAFETY FACTOR:	63.0%
COMMENT:			

KOMATSU PW160-7

**Max Capacity Contours of Radius(m) Plots 2.1m Dipper
Gradient 1 in -25 Height 2m Lift BP**

Unlocked Rail Cant -50mm

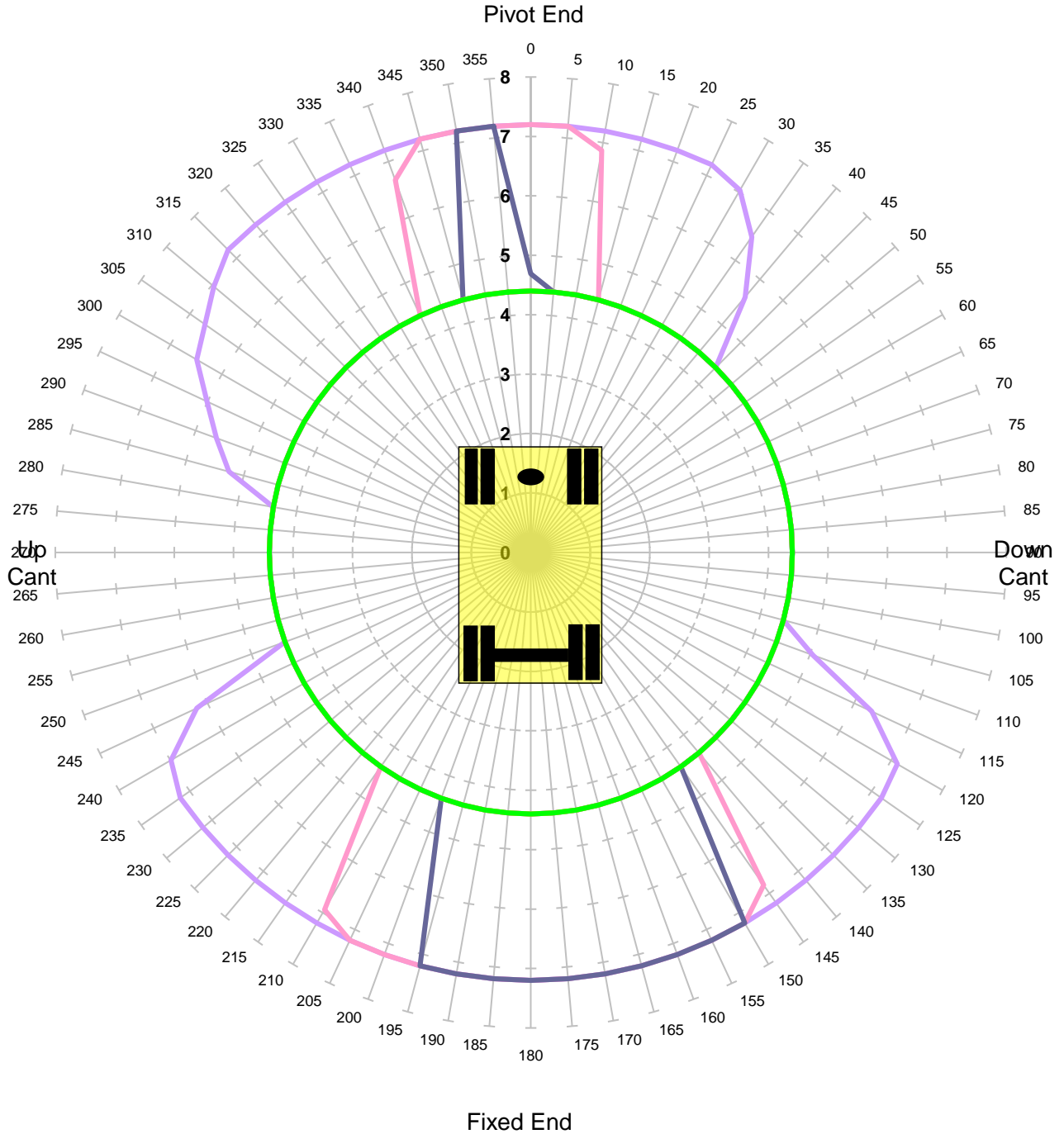

Units in Tonnes

- 1
- 2
- 3
- 4
- 5
- 6
- 7

MACHINE & MODEL:	KOMATSU PW160-7	REFERENCE:	REXQUOTE
SERIAL No:	2325	DATE OF CHART:	7-Feb-2022
EQUIPMENT:	5.15m+2.1m	SAFETY FACTOR:	63.0%
COMMENT:			

KOMATSU PW160-7
Max Capacity Contours of Radius(m) Plots 2.1m Dipper
Gradient 1 in -25 Height 2m Lift BP
Unlocked Rail Cant 50mm

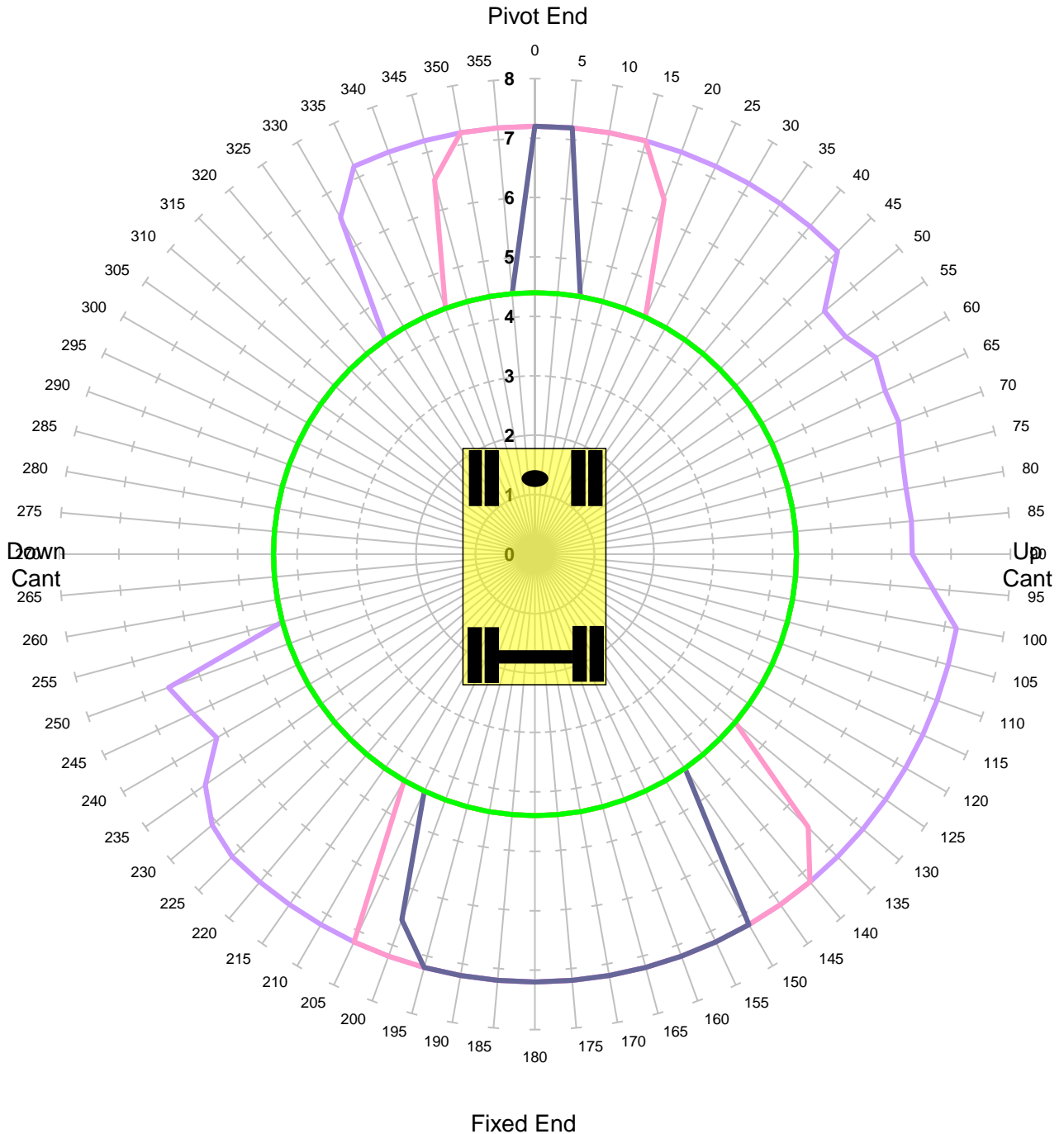

Units in Tonnes

- 1
- 2
- 3
- 4
- 5
- 6
- 7

MACHINE & MODEL:	KOMATSU PW160-7	REFERENCE:	REXQUOTE
SERIAL No:	2325	DATE OF CHART:	7-Feb-2022
EQUIPMENT:	5.15m+2.1m	SAFETY FACTOR:	63.0%
COMMENT:			

KOMATSU PW160-7
Max Capacity Contours of Radius(m) Plots 2.1m Dipper
Gradient 1 in -25 Height 2m Lift BP
Unlocked Rail Cant 150mm

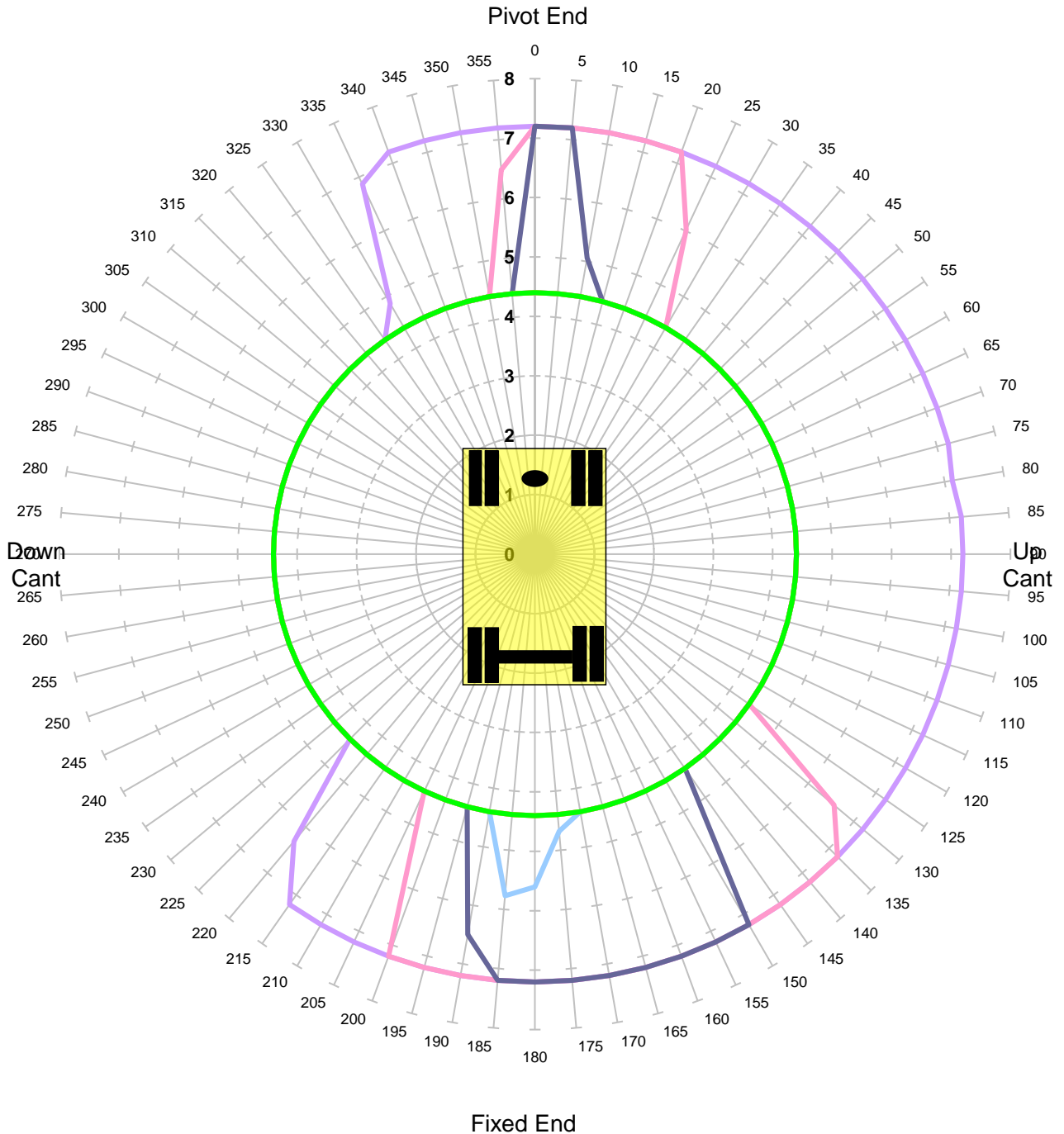

Units in Tonnes

- 1
 — 2
 — 3
 — 4
 — 5
 — 6
 — 7

MACHINE & MODEL: SERIAL No: EQUIPMENT: COMMENT:	KOMATSU PW160-7 2325 5.15m+2.1m	REFERENCE: DATE OF CHART: SAFETY FACTOR:	REXQUOTE 7-Feb-2022 63.0%

KOMATSU PW160-7
Max Capacity Contours of Radius(m) Plots 2.1m Dipper
Gradient 1 in -25 Height 2m Lift BP
Locked Rail Cant -150mm

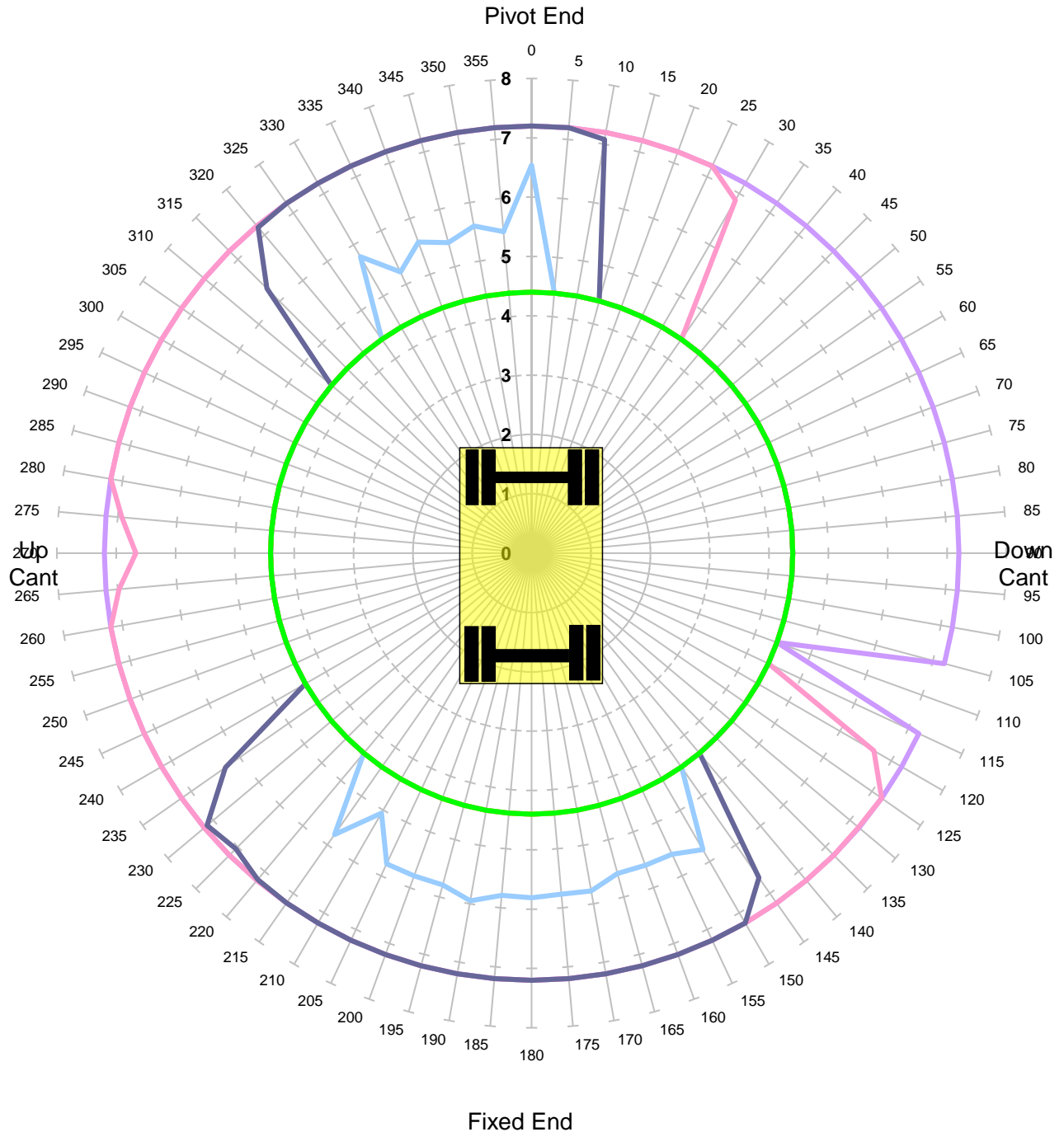

Units in Tonnes

- 1
 — 2
 — 3
 — 4
 — 5
 — 6
 — 7

MACHINE & MODEL:	KOMATSU PW160-7	REFERENCE:	REXQUOTE
SERIAL No:	2325	DATE OF CHART:	7-Feb-2022
EQUIPMENT:	5.15m+2.1m	SAFETY FACTOR:	85.0%
COMMENT:			

KOMATSU PW160-7
Max Capacity Contours of Radius(m) Plots 2.1m Dipper
Gradient 1 in -25 Height 2m Lift BP
Locked Rail Cant -50mm

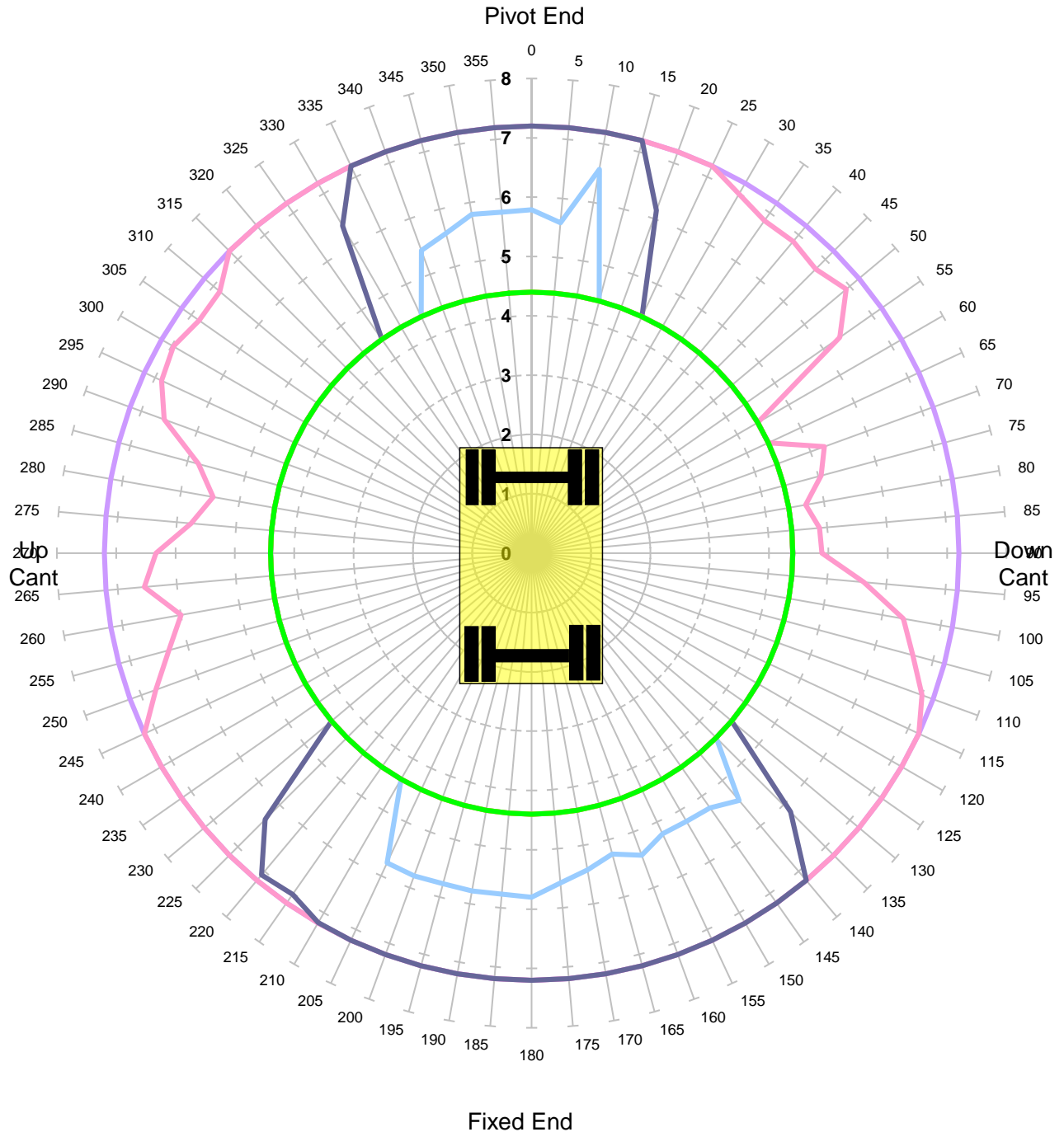

Units in Tonnes

- 1
 — 2
 — 3
 — 4
 — 5
 — 6
 — 7

MACHINE & MODEL:	KOMATSU PW160-7	REFERENCE:	REXQUOTE
SERIAL No:	2325	DATE OF CHART:	7-Feb-2022
EQUIPMENT:	5.15m+2.1m	SAFETY FACTOR:	85.0%
COMMENT:			

KOMATSU PW160-7
Max Capacity Contours of Radius(m) Plots 2.1m Dipper
Gradient 1 in -25 Height 2m Lift BP
Locked Rail Cant 50mm

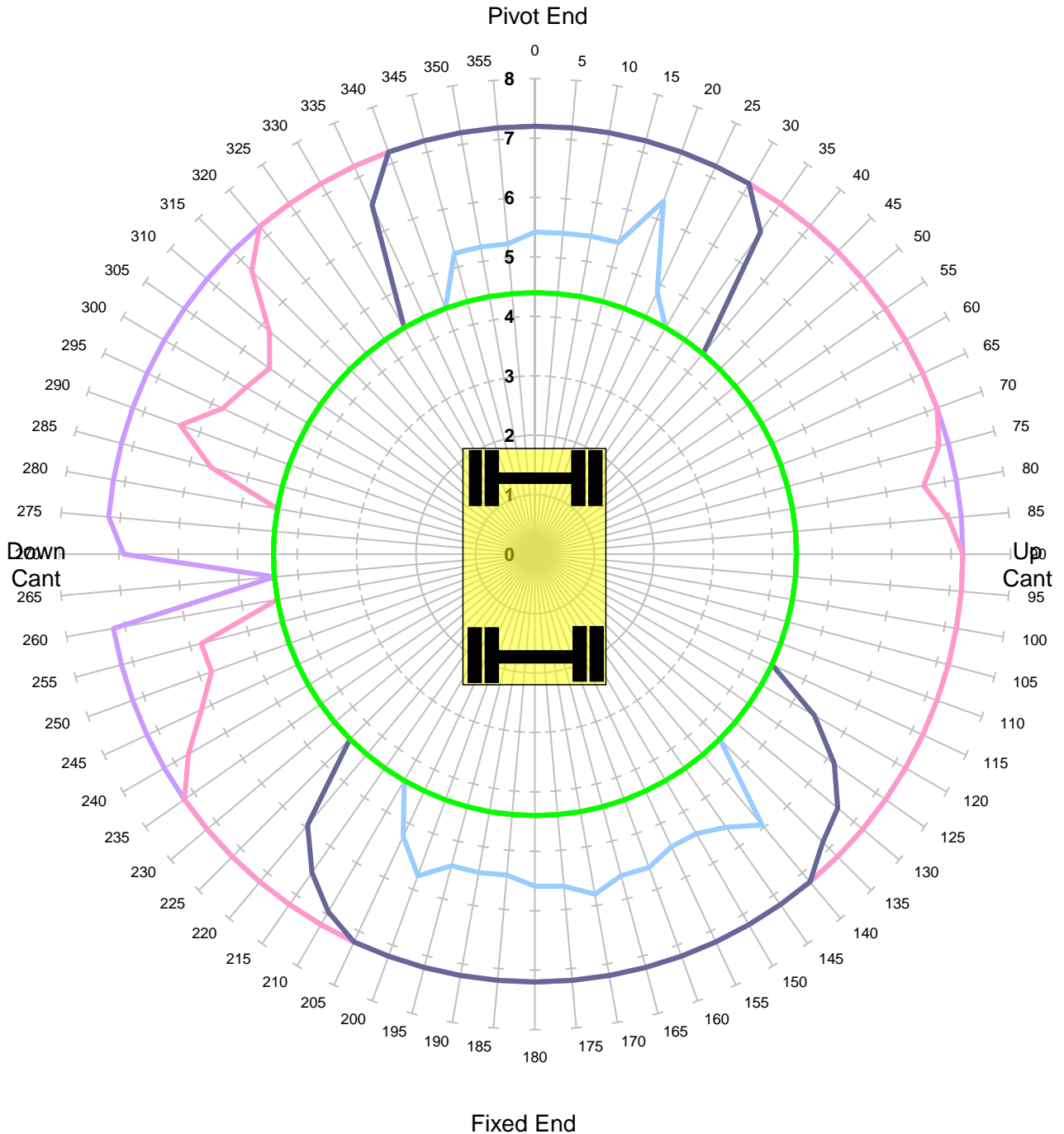

Units in Tonnes

- 1
 — 2
 — 3
 — 4
 — 5
 — 6
 — 7

MACHINE & MODEL:	KOMATSU PW160-7	REFERENCE:	REXQUOTE
SERIAL No:	2325	DATE OF CHART:	7-Feb-2022
EQUIPMENT:	5.15m+2.1m	SAFETY FACTOR:	85.0%
COMMENT:			

KOMATSU PW160-7
Max Capacity Contours of Radius(m) Plots 2.1m Dipper
Gradient 1 in -25 Height 2m Lift BP
Locked Rail Cant 150mm

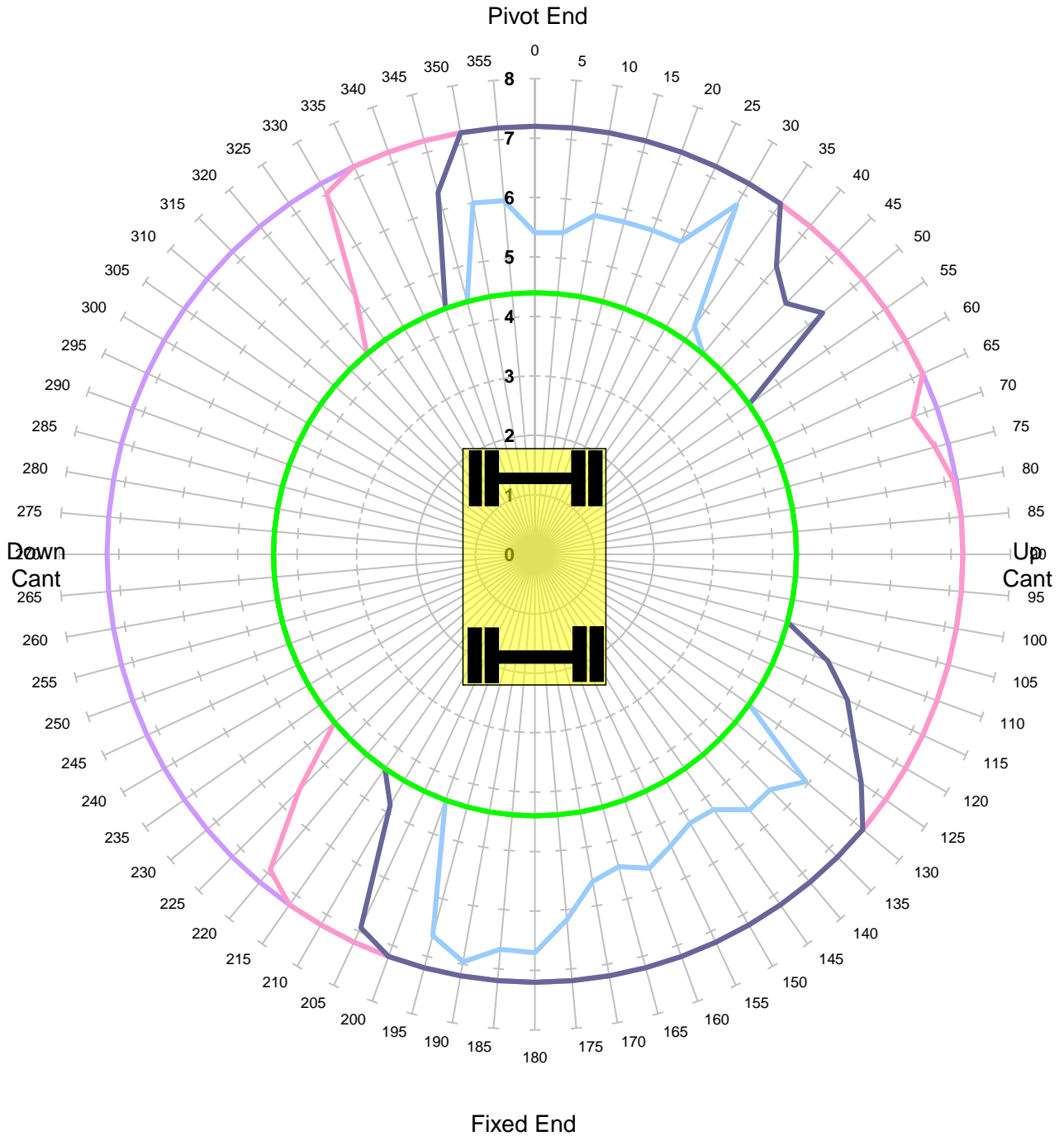

Units in Tonnes

- 1
 — 2
 — 3
 — 4
 — 5
 — 6
 — 7

MACHINE & MODEL:	KOMATSU PW160-7	REFERENCE:	REXQUOTE
SERIAL No:	2325	DATE OF CHART:	7-Feb-2022
EQUIPMENT:	5.15m+2.1m	SAFETY FACTOR:	85.0%
COMMENT:			

KOMATSU PW160-7

**Max Capacity Contours of Radius(m) Plots 2.1m Dipper
Level Ground Height 2m Lift BP**

Unlocked Road

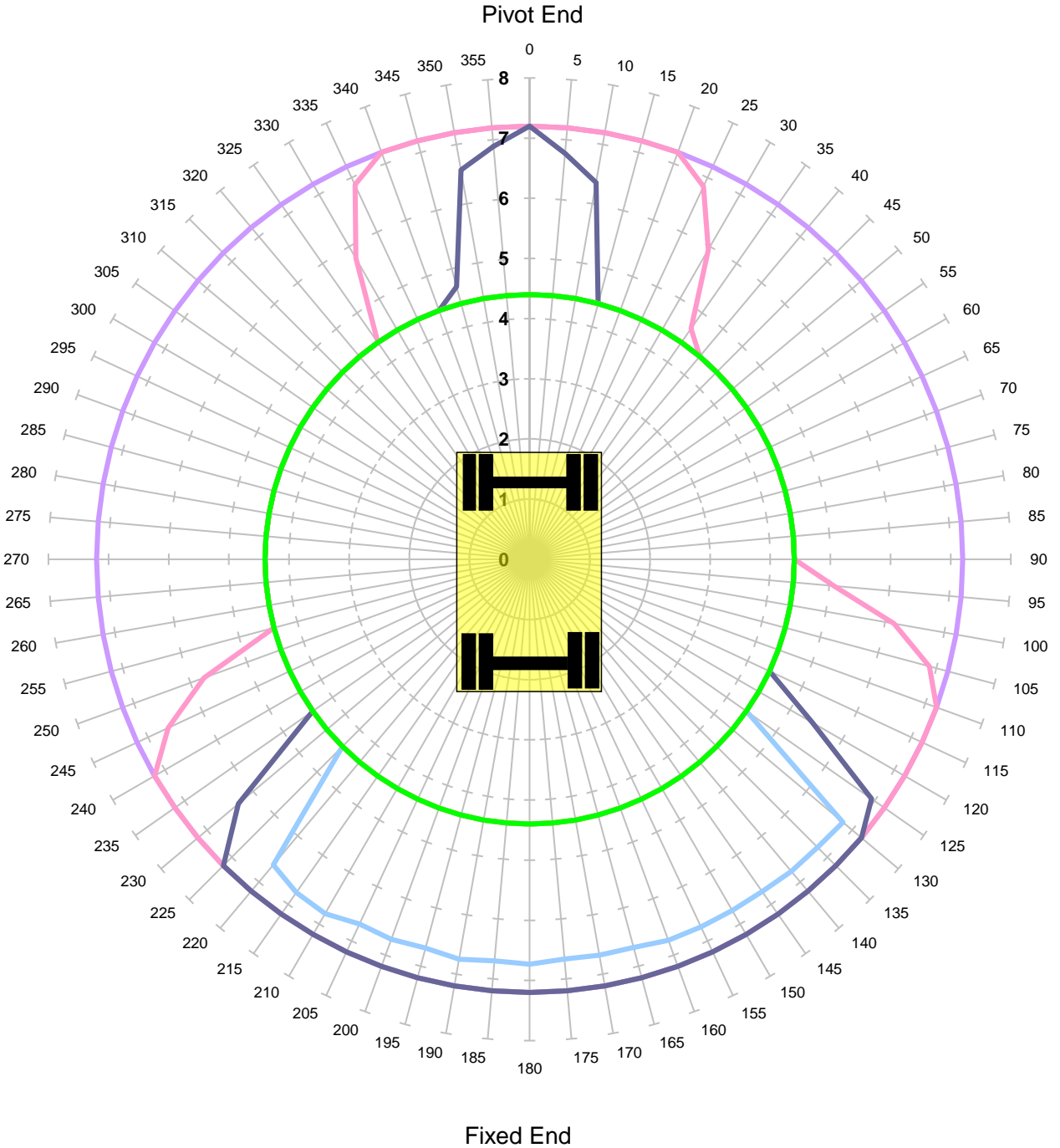

Units in Tonnes

- 1
 — 2
 — 3
 — 4
 — 5
 — 6
 — 7

MACHINE & MODEL:	KOMATSU PW160-7	REFERENCE:	REXQUOTE
SERIAL No:	2325	DATE OF CHART:	7-Feb-2022
EQUIPMENT:	5.15m+2.1m	SAFETY FACTOR:	67.0%
COMMENT:			

KOMATSU PW160-7

**Max Capacity Contours of Radius(m) Plots 2.1m Dipper
Level Ground Height 2m Lift BP
Locked Road**

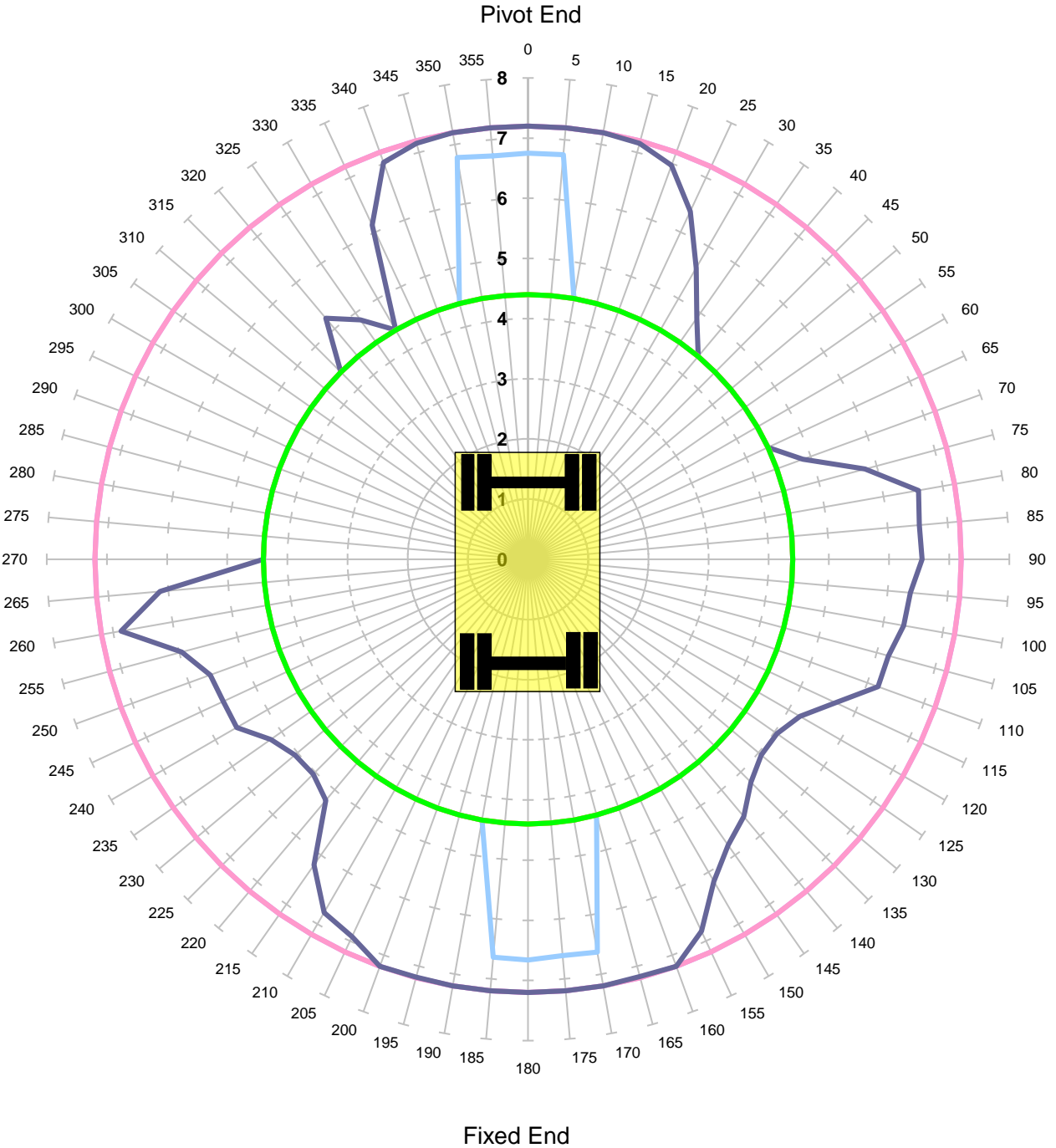

Units in Tonnes

- 1
- 2
- 3
- 4
- 5
- 6
- 7

MACHINE & MODEL:	KOMATSU PW160-7	REFERENCE:	REXQUOTE
SERIAL No:	2325	DATE OF CHART:	7-Feb-2022
EQUIPMENT:	5.15m+2.1m	SAFETY FACTOR:	67.0%
COMMENT:			

KOMATSU PW160-7

**Max Capacity Contours of Radius(m) Plots 2.1m Dipper
Gradient 1 in -25 Height 2m Lift BP**

Unlocked Rail Cant -150mm - Tandem Lift

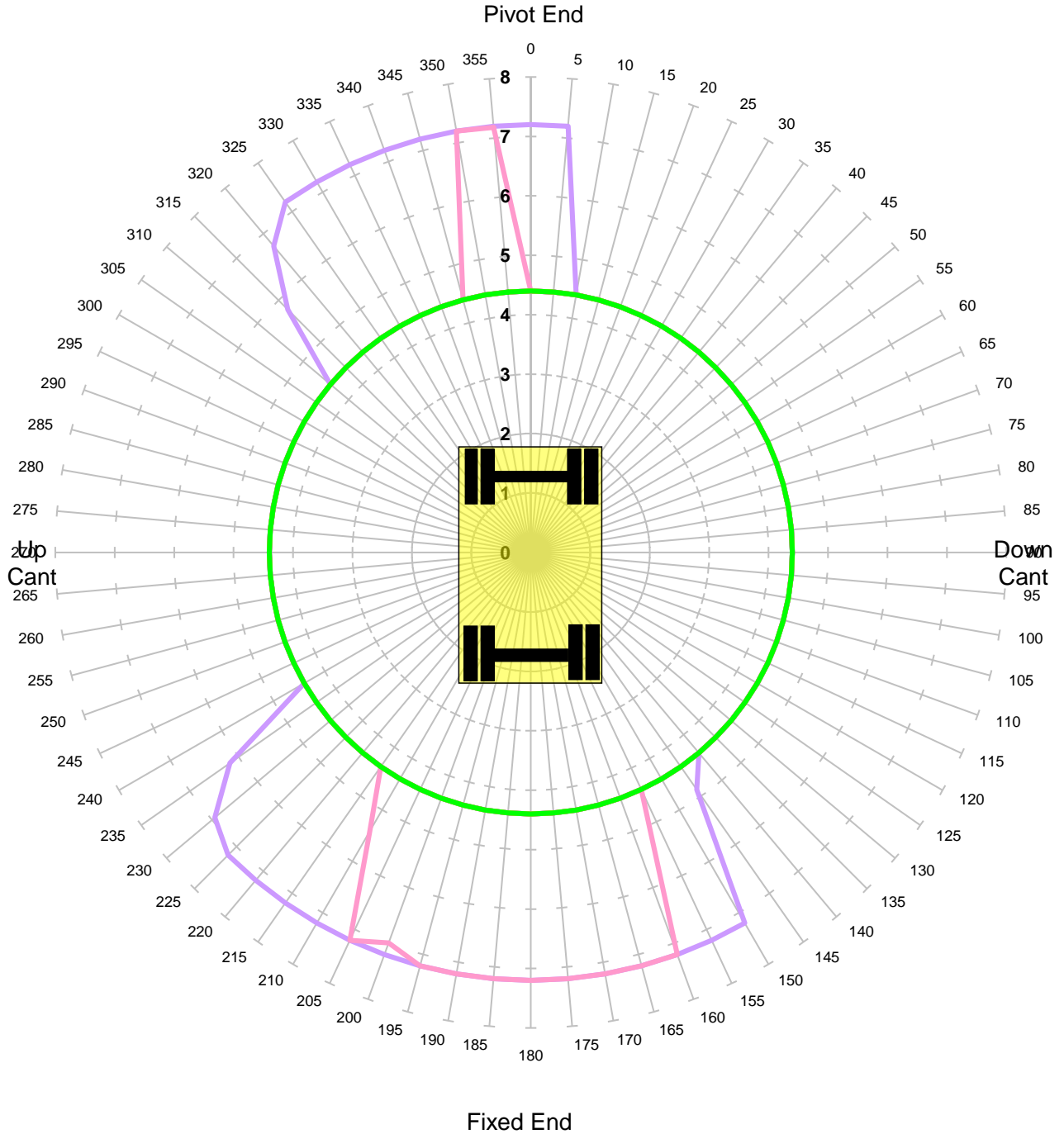

Units in Tonnes

- 1
- 2
- 3
- 4
- 5
- 6
- 7

MACHINE & MODEL:	KOMATSU PW160-7	REFERENCE:	REXQUOTE
SERIAL No:	2325	DATE OF CHART:	7-Feb-2022
EQUIPMENT:	5.15m+2.1m	SAFETY FACTOR:	39.0%
COMMENT:			

KOMATSU PW160-7

**Max Capacity Contours of Radius(m) Plots 2.1m Dipper
Gradient 1 in -25 Height 2m Lift BP**

Unlocked Rail Cant -50mm - Tandem Lift

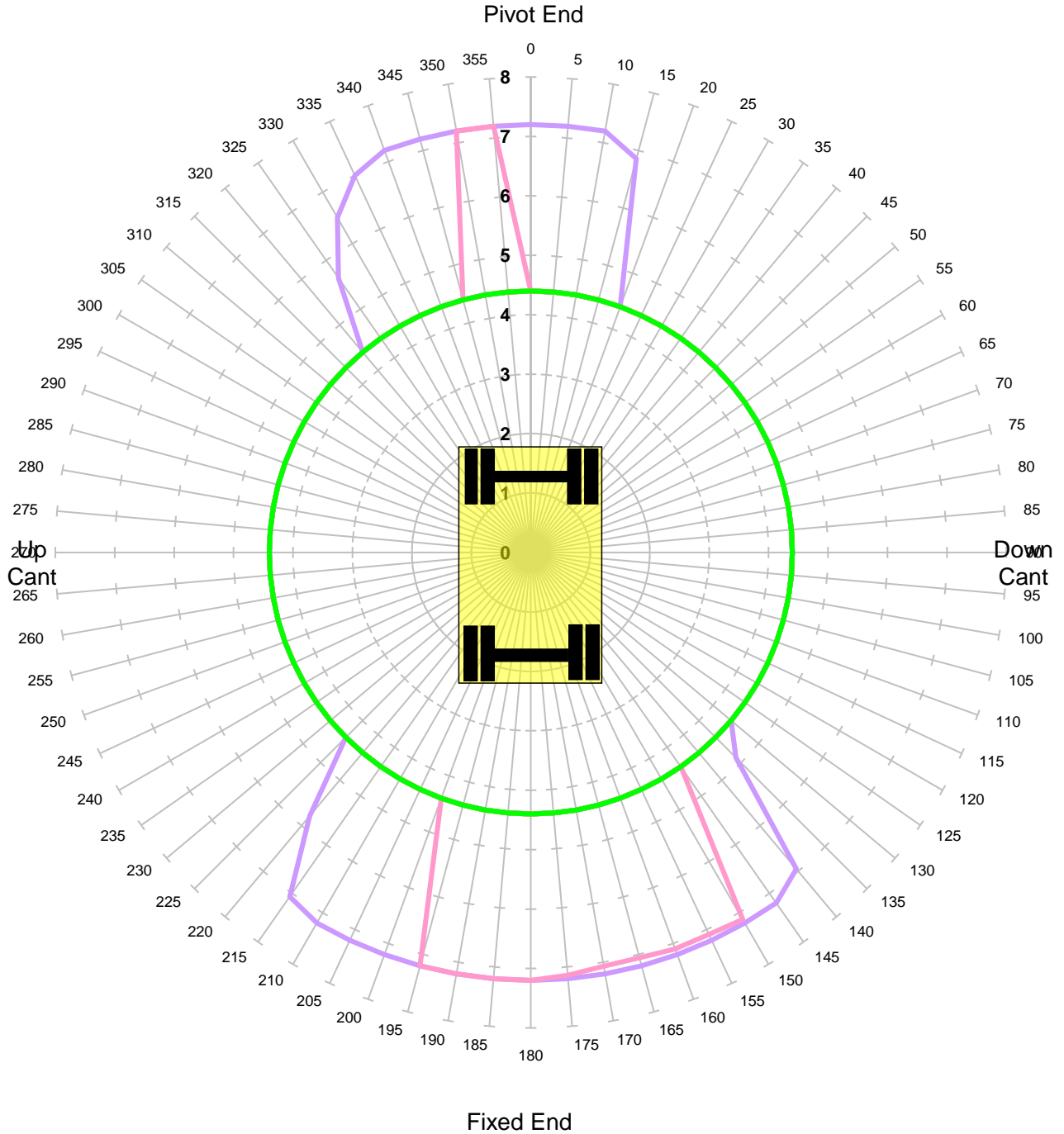

Units in Tonnes

- 1
- 2
- 3
- 4
- 5
- 6
- 7

MACHINE & MODEL:	KOMATSU PW160-7	REFERENCE:	REXQUOTE
SERIAL No:	2325	DATE OF CHART:	7-Feb-2022
EQUIPMENT:	5.15m+2.1m	SAFETY FACTOR:	39.0%
COMMENT:			

KOMATSU PW160-7

**Max Capacity Contours of Radius(m) Plots 2.1m Dipper
Gradient 1 in -25 Height 2m Lift BP**

Unlocked Rail Cant 50mm - Tandem Lift

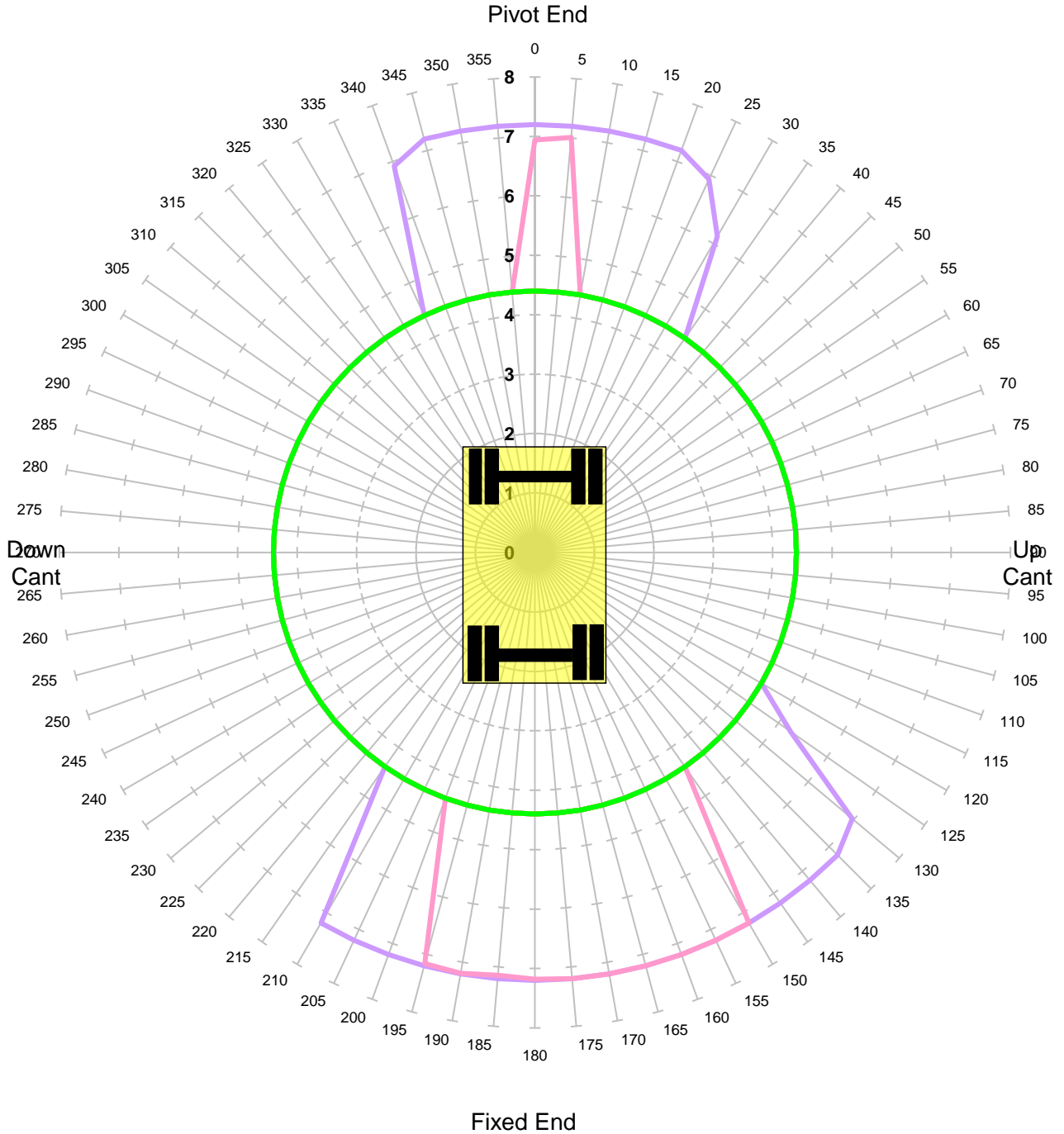

Units in Tonnes

- 1
- 2
- 3
- 4
- 5
- 6
- 7

MACHINE & MODEL:	KOMATSU PW160-7	REFERENCE:	REXQUOTE
SERIAL No:	2325	DATE OF CHART:	7-Feb-2022
EQUIPMENT:	5.15m+2.1m	SAFETY FACTOR:	39.0%
COMMENT:			

KOMATSU PW160-7

**Max Capacity Contours of Radius(m) Plots 2.1m Dipper
Gradient 1 in -25 Height 2m Lift BP**

Unlocked Rail Cant 150mm - Tandem Lift

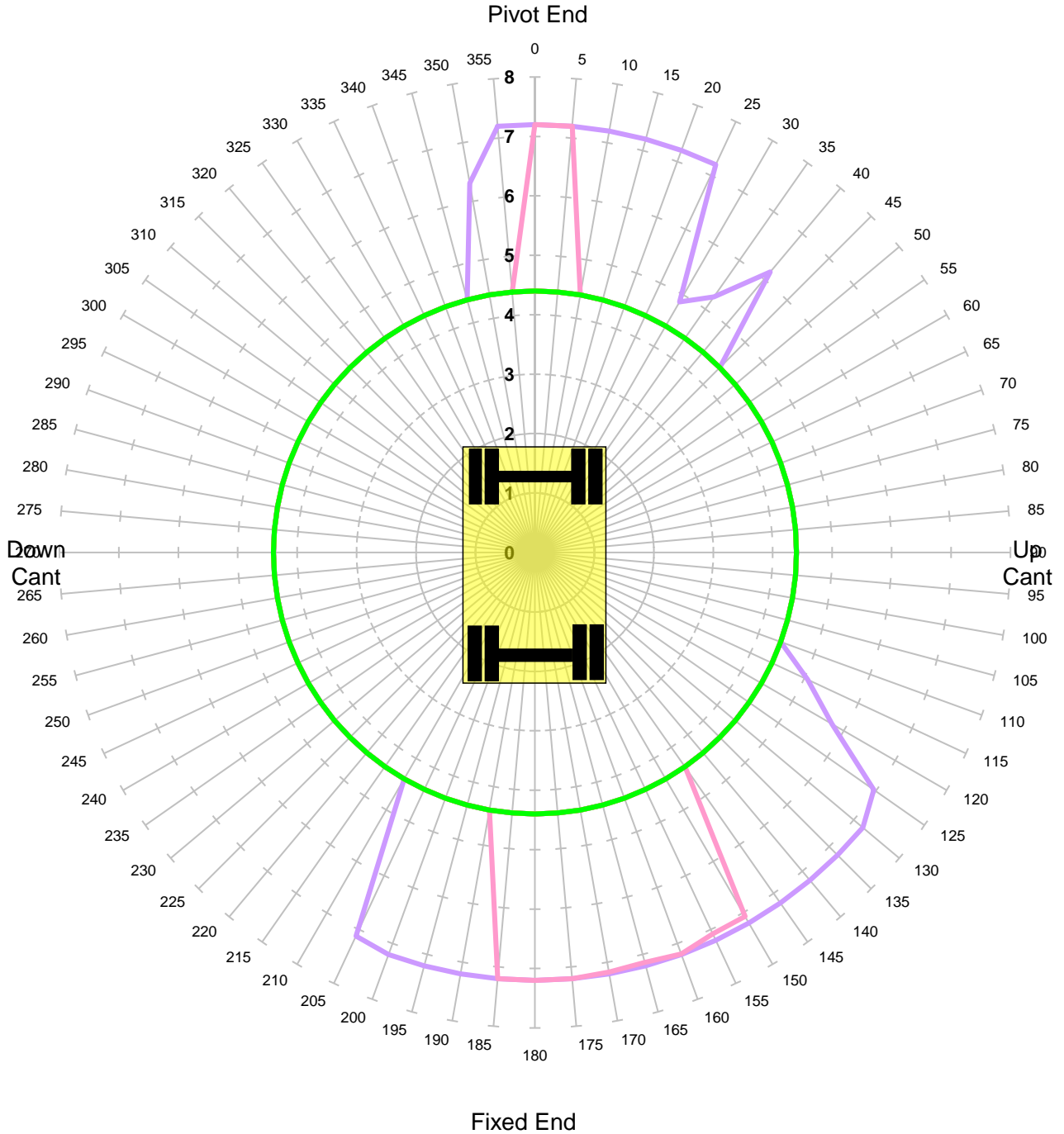

Units in Tonnes

- 1
- 2
- 3
- 4
- 5
- 6
- 7

MACHINE & MODEL:	KOMATSU PW160-7	REFERENCE:	REXQUOTE
SERIAL No:	2325	DATE OF CHART:	7-Feb-2022
EQUIPMENT:	5.15m+2.1m	SAFETY FACTOR:	39.0%
COMMENT:			

KOMATSU PW160-7

**Max Capacity Contours of Radius(m) Plots 2.1m Dipper
Gradient 1 in -25 Height 2m Lift BP**

Locked Rail Cant -150mm - Tandem Lift

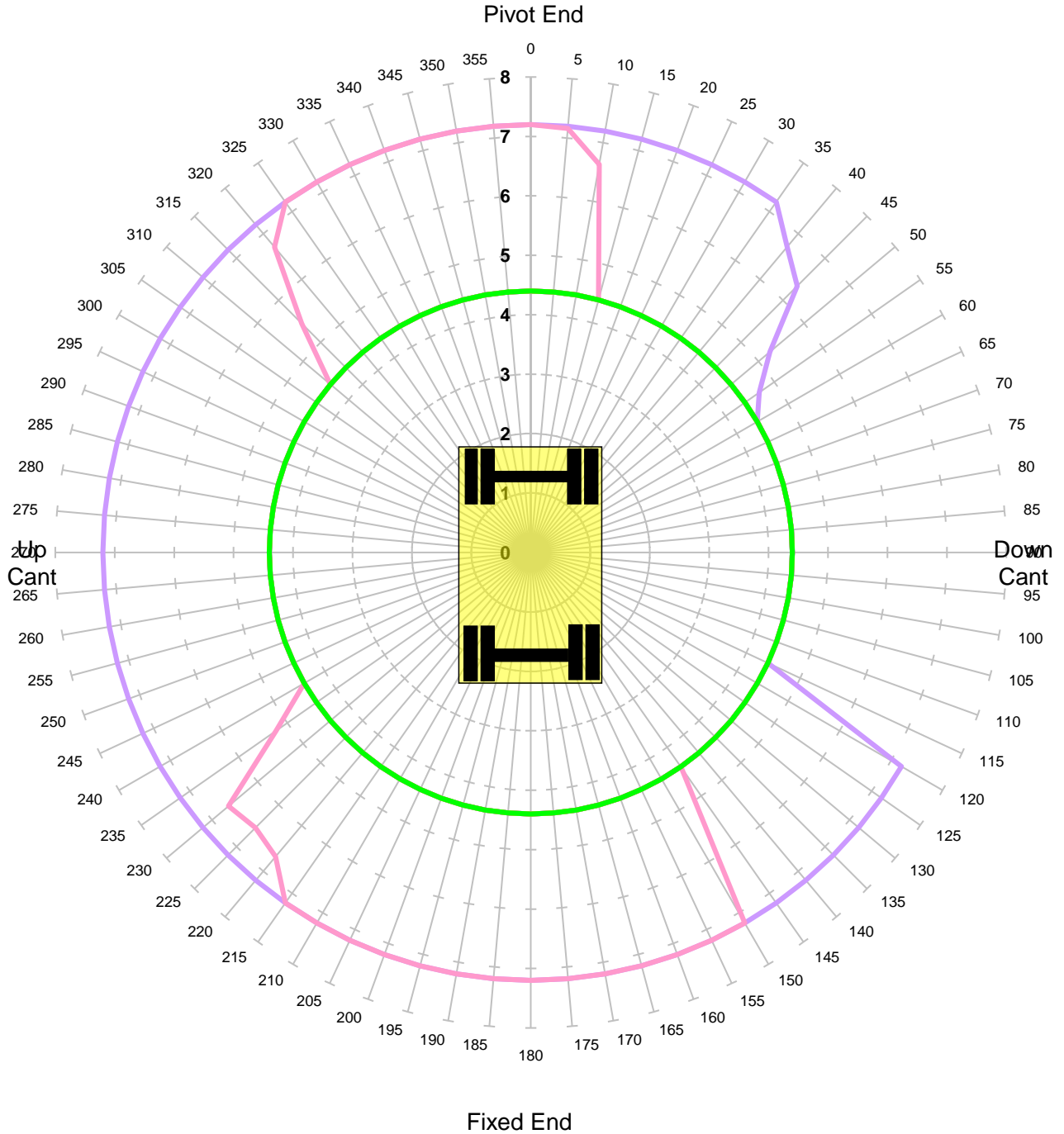

Units in Tonnes

- 1
- 2
- 3
- 4
- 5
- 6
- 7

MACHINE & MODEL:	KOMATSU PW160-7	REFERENCE:	REXQUOTE
SERIAL No:	2325	DATE OF CHART:	7-Feb-2022
EQUIPMENT:	5.15m+2.1m	SAFETY FACTOR:	53.0%
COMMENT:			

KOMATSU PW160-7

**Max Capacity Contours of Radius(m) Plots 2.1m Dipper
Gradient 1 in -25 Height 2m Lift BP**

Locked Rail Cant -50mm - Tandem Lift

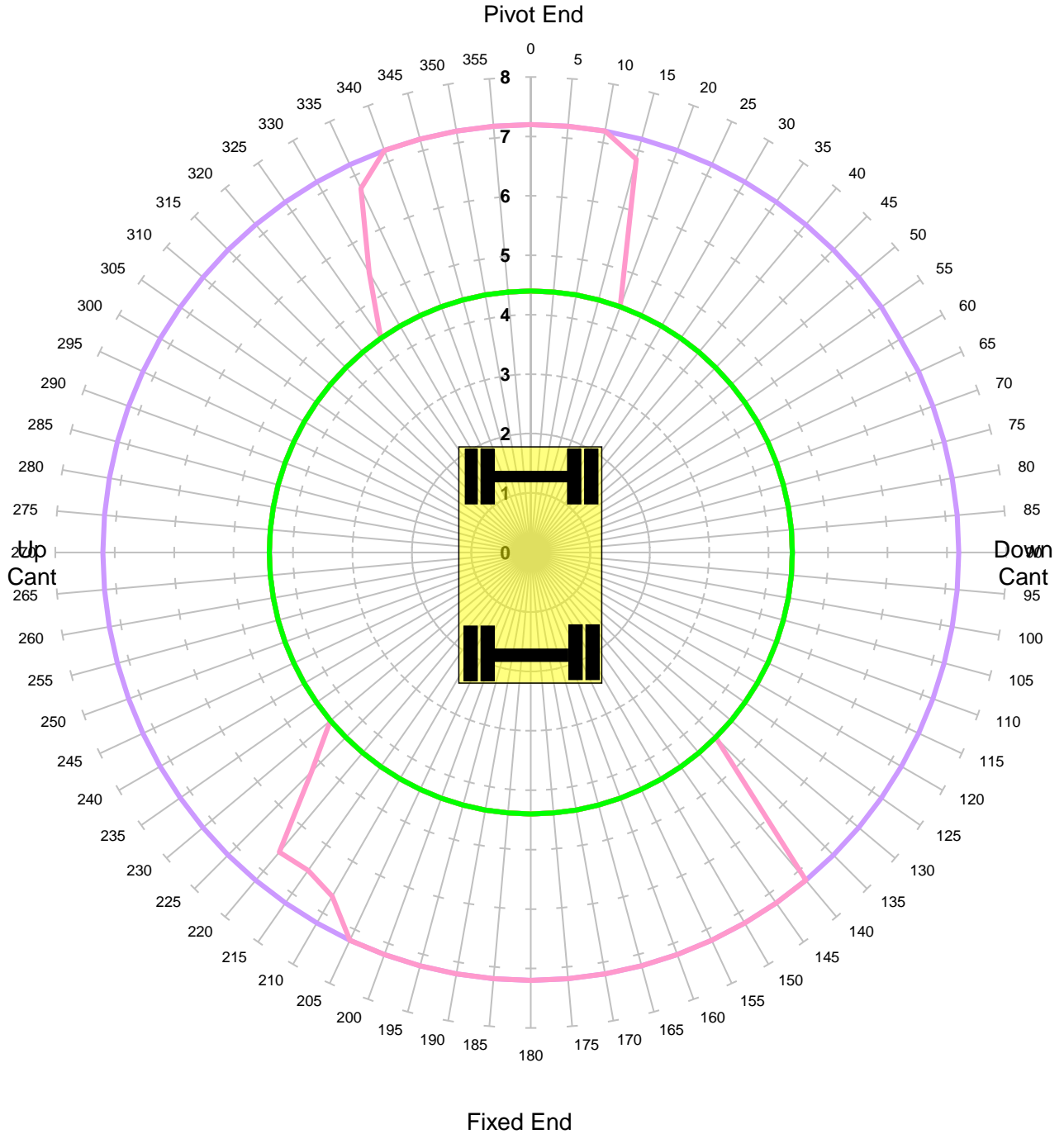

Units in Tonnes

- 1
- 2
- 3
- 4
- 5
- 6
- 7

MACHINE & MODEL:	KOMATSU PW160-7	REFERENCE:	REXQUOTE
SERIAL No:	2325	DATE OF CHART:	7-Feb-2022
EQUIPMENT:	5.15m+2.1m	SAFETY FACTOR:	53.0%
COMMENT:			

KOMATSU PW160-7

**Max Capacity Contours of Radius(m) Plots 2.1m Dipper
Gradient 1 in -25 Height 2m Lift BP**

Locked Rail Cant 50mm - Tandem Lift

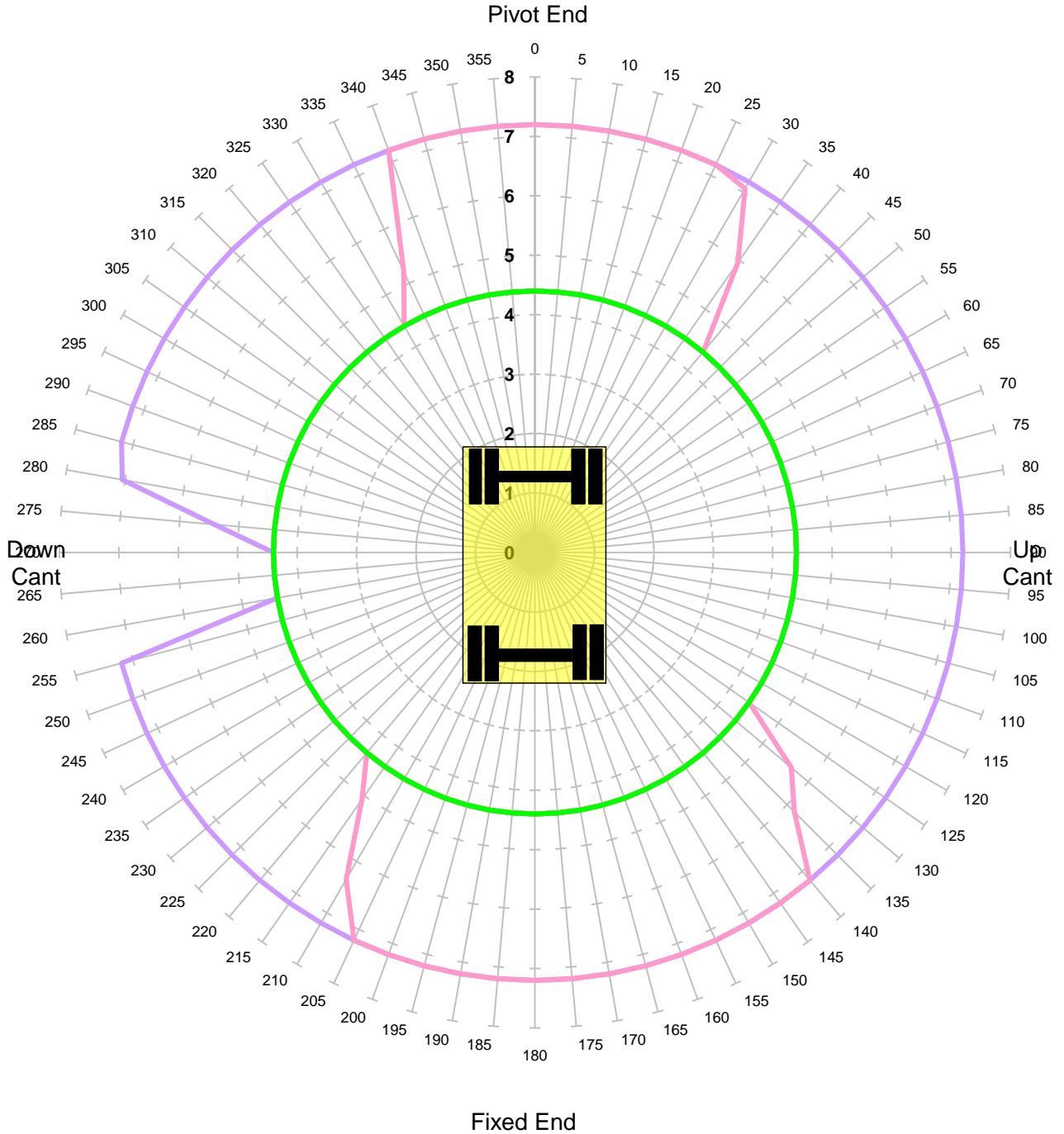

Units in Tonnes

- 1
- 2
- 3
- 4
- 5
- 6
- 7

MACHINE & MODEL:	KOMATSU PW160-7	REFERENCE:	REXQUOTE
SERIAL No:	2325	DATE OF CHART:	7-Feb-2022
EQUIPMENT:	5.15m+2.1m	SAFETY FACTOR:	53.0%
COMMENT:			

KOMATSU PW160-7

**Max Capacity Contours of Radius(m) Plots 2.1m Dipper
Gradient 1 in -25 Height 2m Lift BP**

Locked Rail Cant 150mm - Tandem Lift

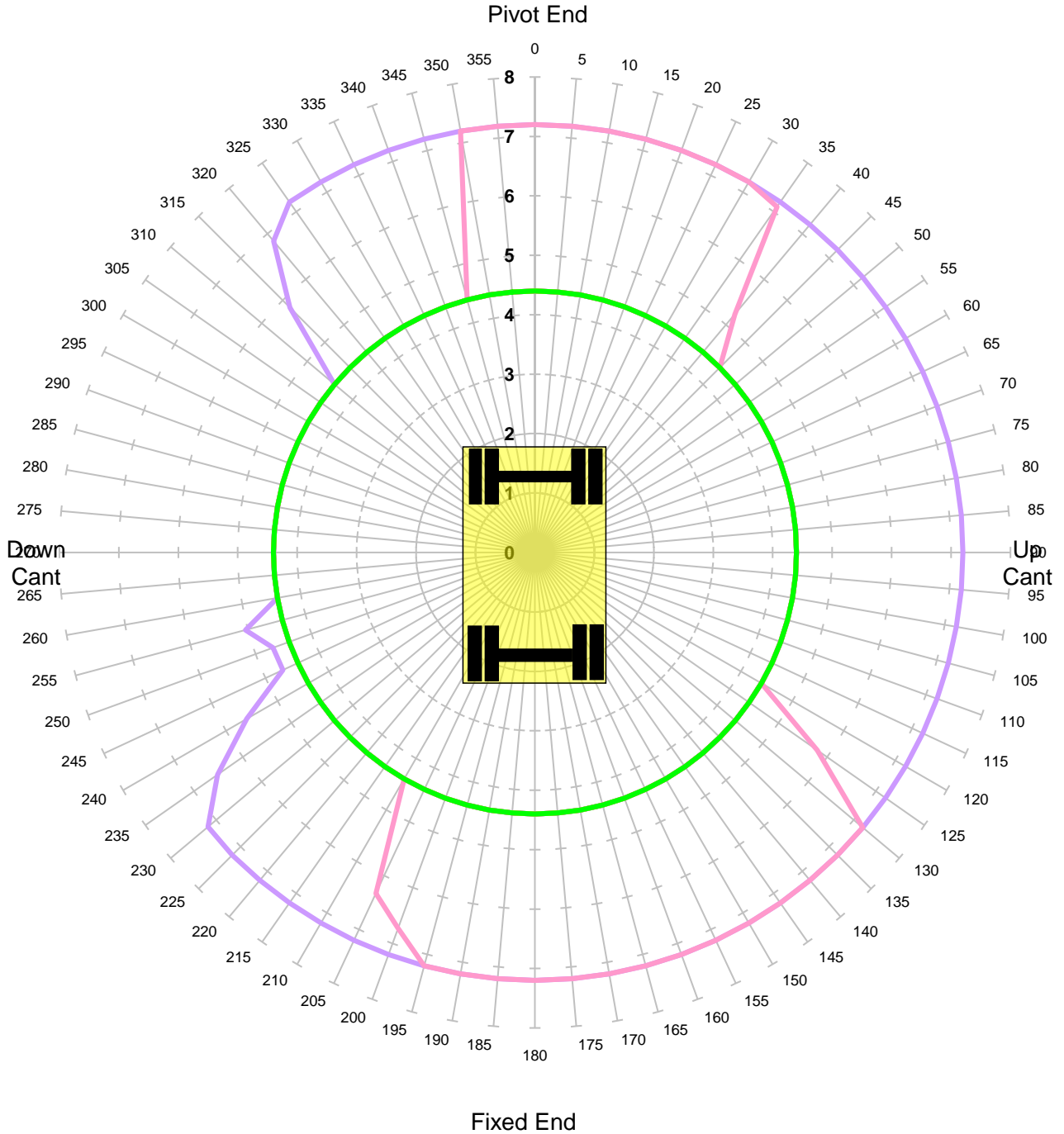

Units in Tonnes

- 1
- 2
- 3
- 4
- 5
- 6
- 7

MACHINE & MODEL:	KOMATSU PW160-7	REFERENCE:	REXQUOTE
SERIAL No:	2325	DATE OF CHART:	7-Feb-2022
EQUIPMENT:	5.15m+2.1m	SAFETY FACTOR:	53.0%
COMMENT:			

KOMATSU PW160-7

**Max Capacity Contours of Radius(m) Plots 2.1m Dipper
Level Ground Height 2m Lift BP
Unlocked Road - Tandem Lift**

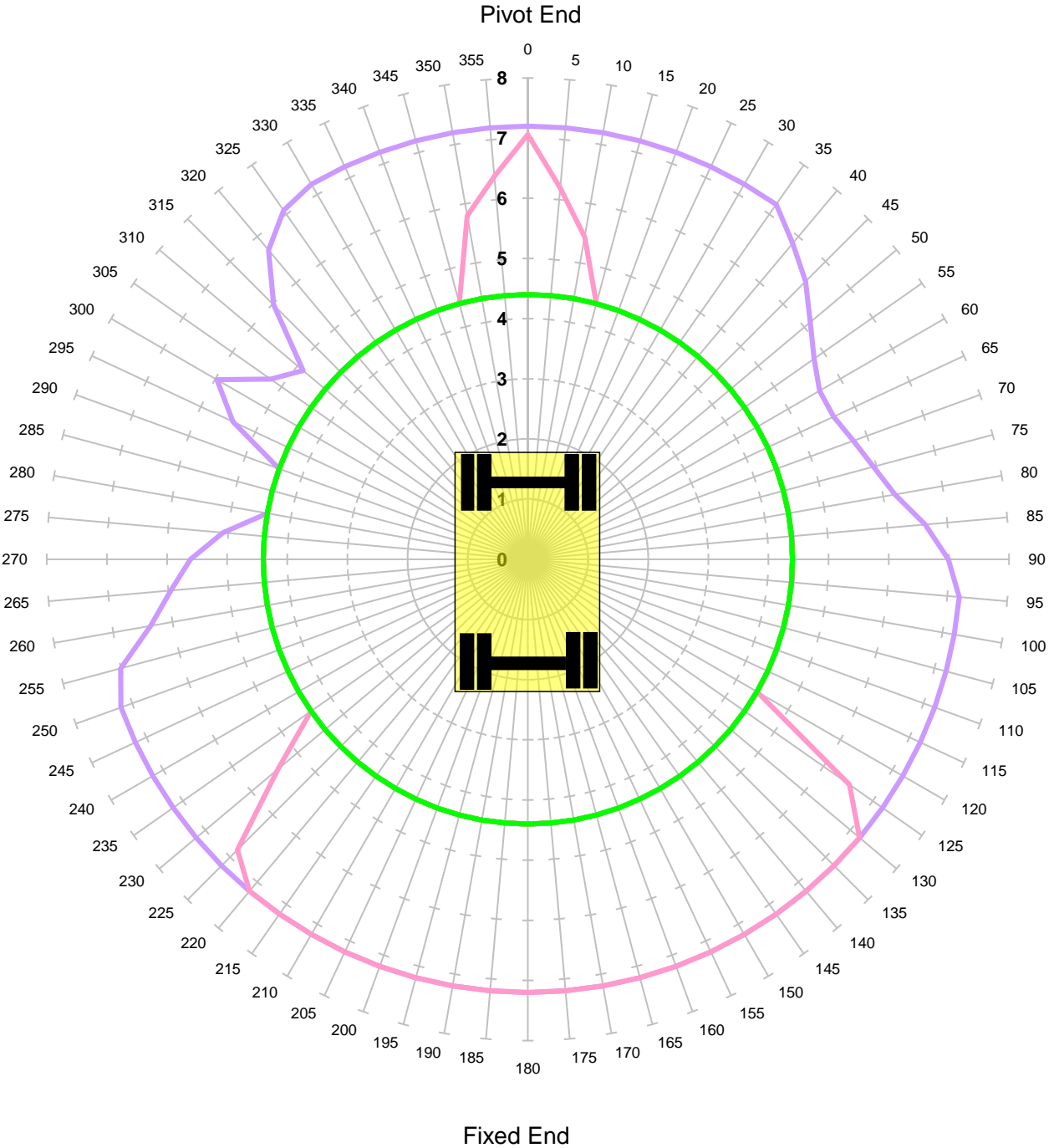

Units in Tonnes

- 1
- 2
- 3
- 4
- 5
- 6
- 7

MACHINE & MODEL:	KOMATSU PW160-7	REFERENCE:	REXQUOTE
SERIAL No:	2325	DATE OF CHART:	7-Feb-2022
EQUIPMENT:	5.15m+2.1m	SAFETY FACTOR:	42.0%
COMMENT:			

KOMATSU PW160-7
Max Capacity Contours of Radius(m) Plots 2.1m Dipper
Level Ground Height 2m Lift BP
Locked Road - Tandem Lift

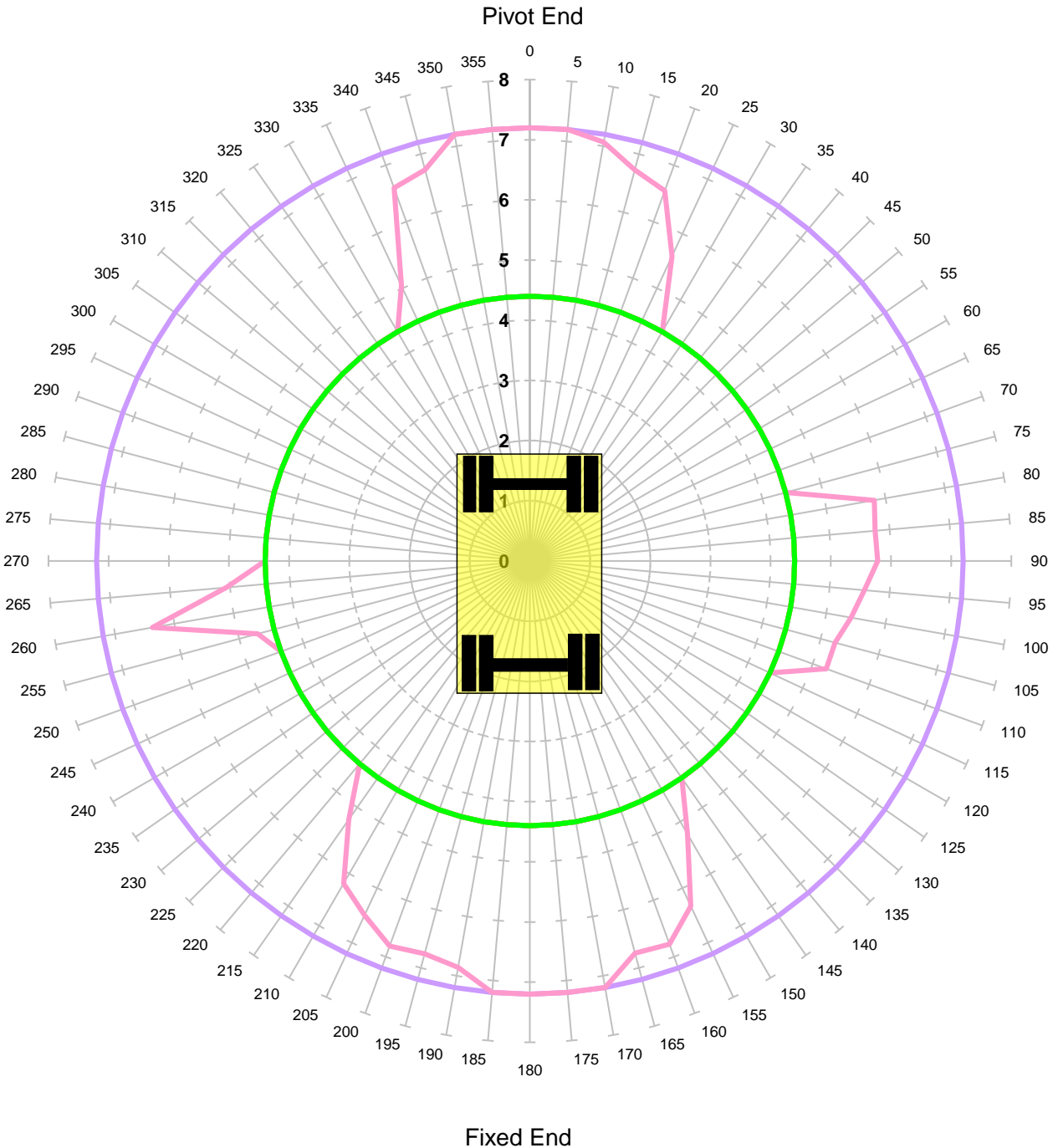

Units in Tonnes

- 1
 — 2
 — 3
 — 4
 — 5
 — 6
 — 7

MACHINE & MODEL:	KOMATSU PW160-7	REFERENCE:	REXQUOTE
SERIAL No:	2325	DATE OF CHART:	7-Feb-2022
EQUIPMENT:	5.15m+2.1m	SAFETY FACTOR:	42.0%
COMMENT:			

KOMATSU PW160-7
Max Capacity Contours of Radius(m) Plots 2.1m Dipper
Gradient 1 in -25 Height 2m Lift QH
Unlocked Rail Cant -150mm

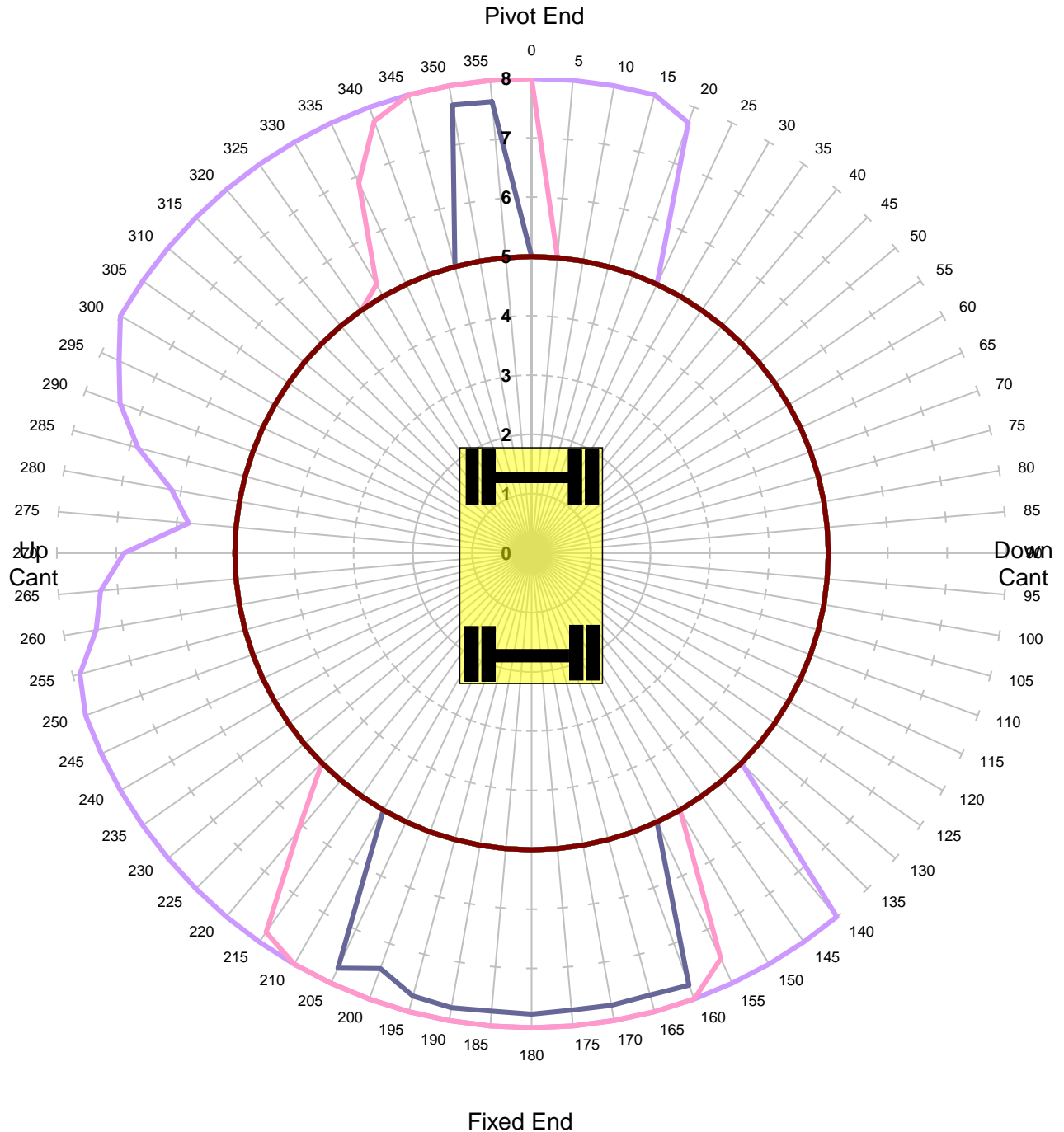

MACHINE & MODEL:	KOMATSU PW160-7	REFERENCE:	REXQUOTE
SERIAL No:	2325	DATE OF CHART:	7-Feb-2022
EQUIPMENT:	5.15m+2.1m	SAFETY FACTOR:	63.0%
COMMENT:			

KOMATSU PW160-7
Max Capacity Contours of Radius(m) Plots 2.1m Dipper
Gradient 1 in -25 Height 2m Lift QH
Unlocked Rail Cant -50mm

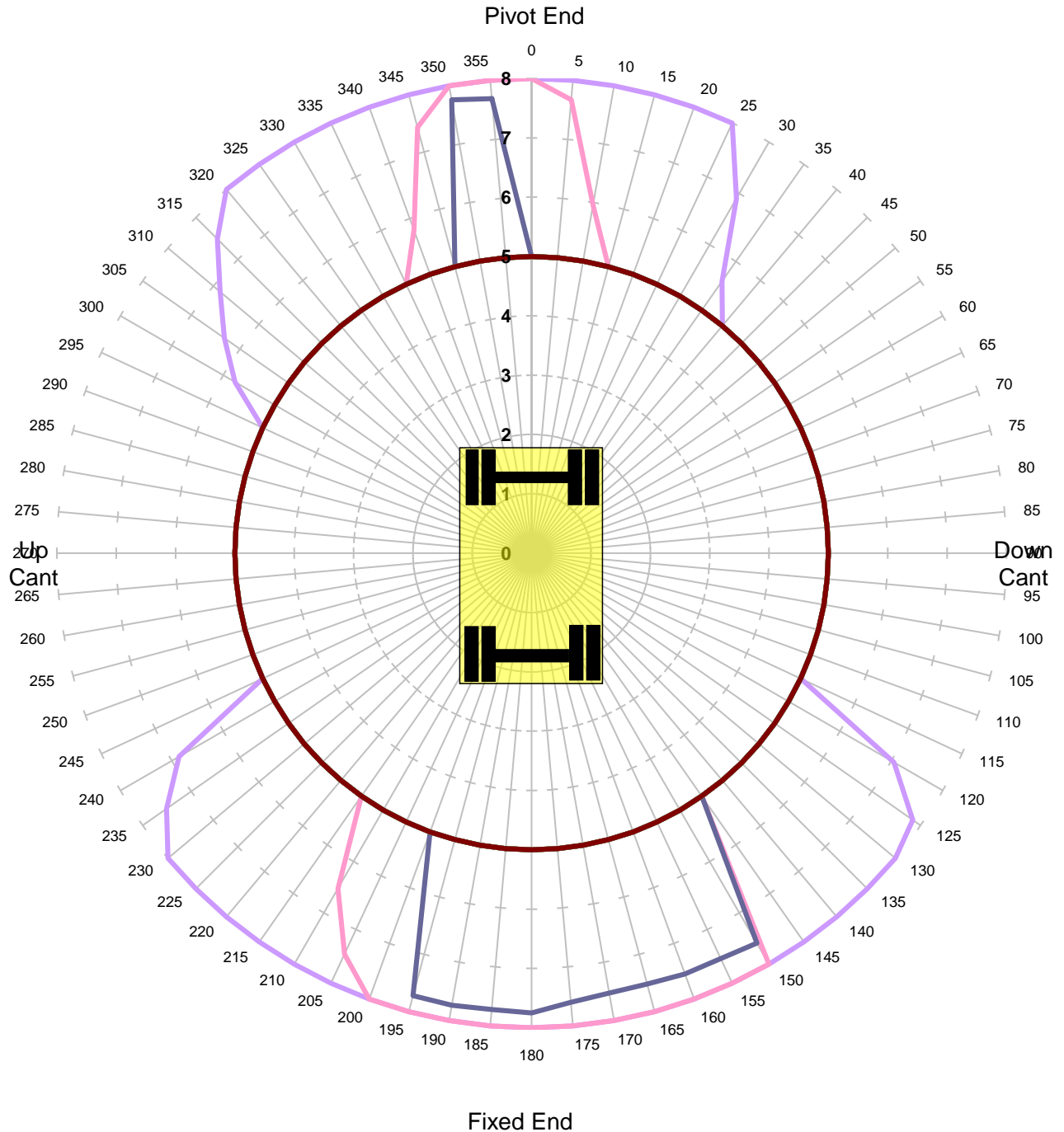

Units in Tonnes

- 1
- 2
- 3
- 4
- 5
- 6
- 7
- 8
- 9
- 10
- 11
- 12
- 13

MACHINE & MODEL:	KOMATSU PW160-7	REFERENCE:	REXQUOTE
SERIAL No:	2325	DATE OF CHART:	7-Feb-2022
EQUIPMENT:	5.15m+2.1m	SAFETY FACTOR:	63.0%
COMMENT:			

KOMATSU PW160-7

**Max Capacity Contours of Radius(m) Plots 2.1m Dipper
Gradient 1 in -25 Height 2m Lift QH**

Unlocked Rail Cant 50mm

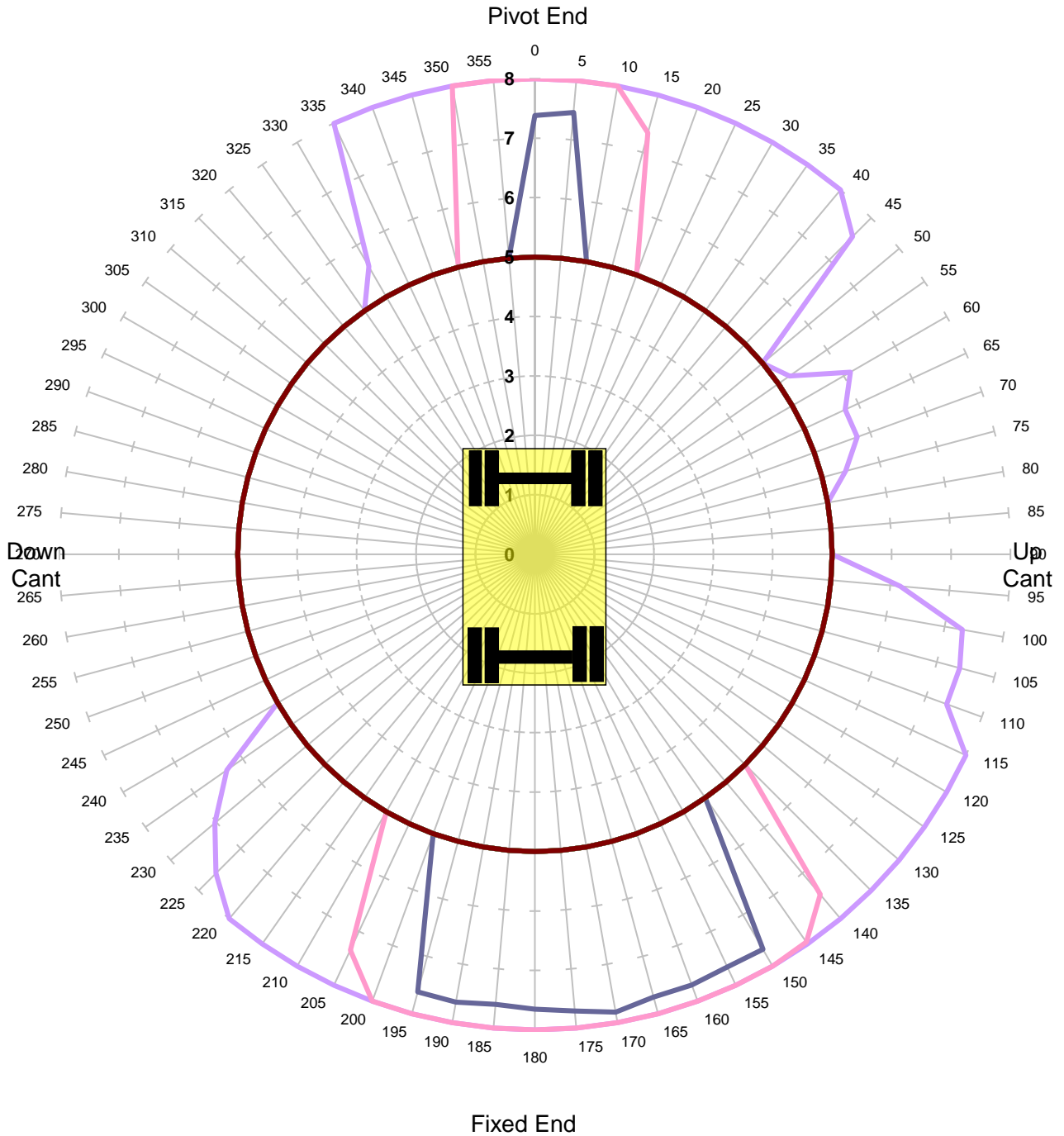

Units in Tonnes

-
-
-
-
-
-
-
-
-
-
-
-
-

MACHINE & MODEL:	KOMATSU PW160-7	REFERENCE:	REXQUOTE
SERIAL No:	2325	DATE OF CHART:	7-Feb-2022
EQUIPMENT:	5.15m+2.1m	SAFETY FACTOR:	63.0%
COMMENT:			

KOMATSU PW160-7
Max Capacity Contours of Radius(m) Plots 2.1m Dipper
Gradient 1 in -25 Height 2m Lift QH
Unlocked Rail Cant 150mm

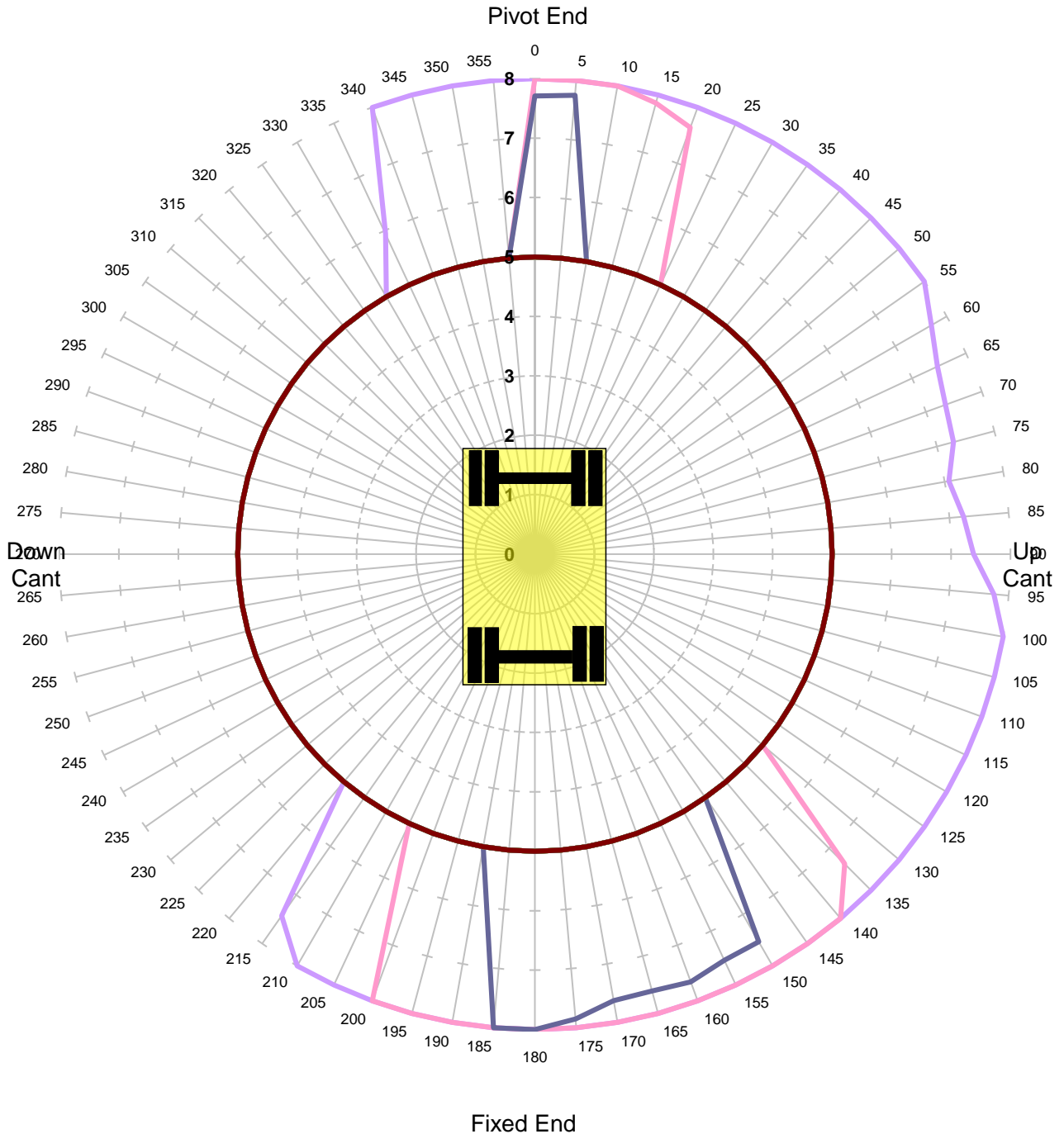

Units in Tonnes

- 1
 — 2
 — 3
 — 4
 — 5
 — 6
 — 7
 — 8
 — 9
 — 10
 — 11
 — 12
 — 13

MACHINE & MODEL:	KOMATSU PW160-7	REFERENCE:	REXQUOTE
SERIAL No:	2325	DATE OF CHART:	7-Feb-2022
EQUIPMENT:	5.15m+2.1m	SAFETY FACTOR:	63.0%
COMMENT:			

KOMATSU PW160-7
Max Capacity Contours of Radius(m) Plots 2.1m Dipper
Gradient 1 in -25 Height 2m Lift QH
Locked Rail Cant -150mm

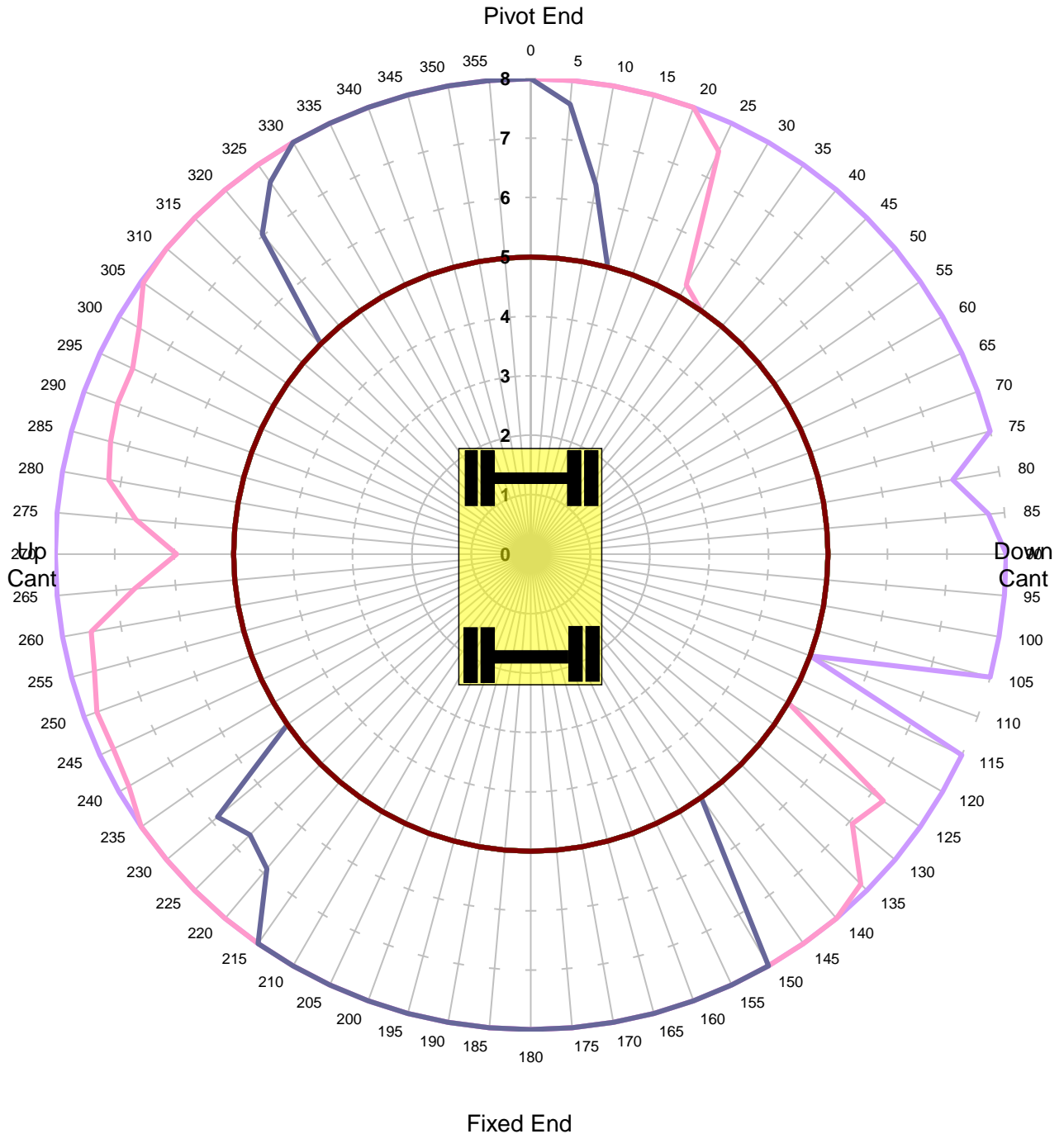

MACHINE & MODEL:	KOMATSU PW160-7	REFERENCE:	REXQUOTE
SERIAL No:	2325	DATE OF CHART:	7-Feb-2022
EQUIPMENT:	5.15m+2.1m	SAFETY FACTOR:	85.0%
COMMENT:			

KOMATSU PW160-7
Max Capacity Contours of Radius(m) Plots 2.1m Dipper
Gradient 1 in -25 Height 2m Lift QH
Locked Rail Cant -50mm

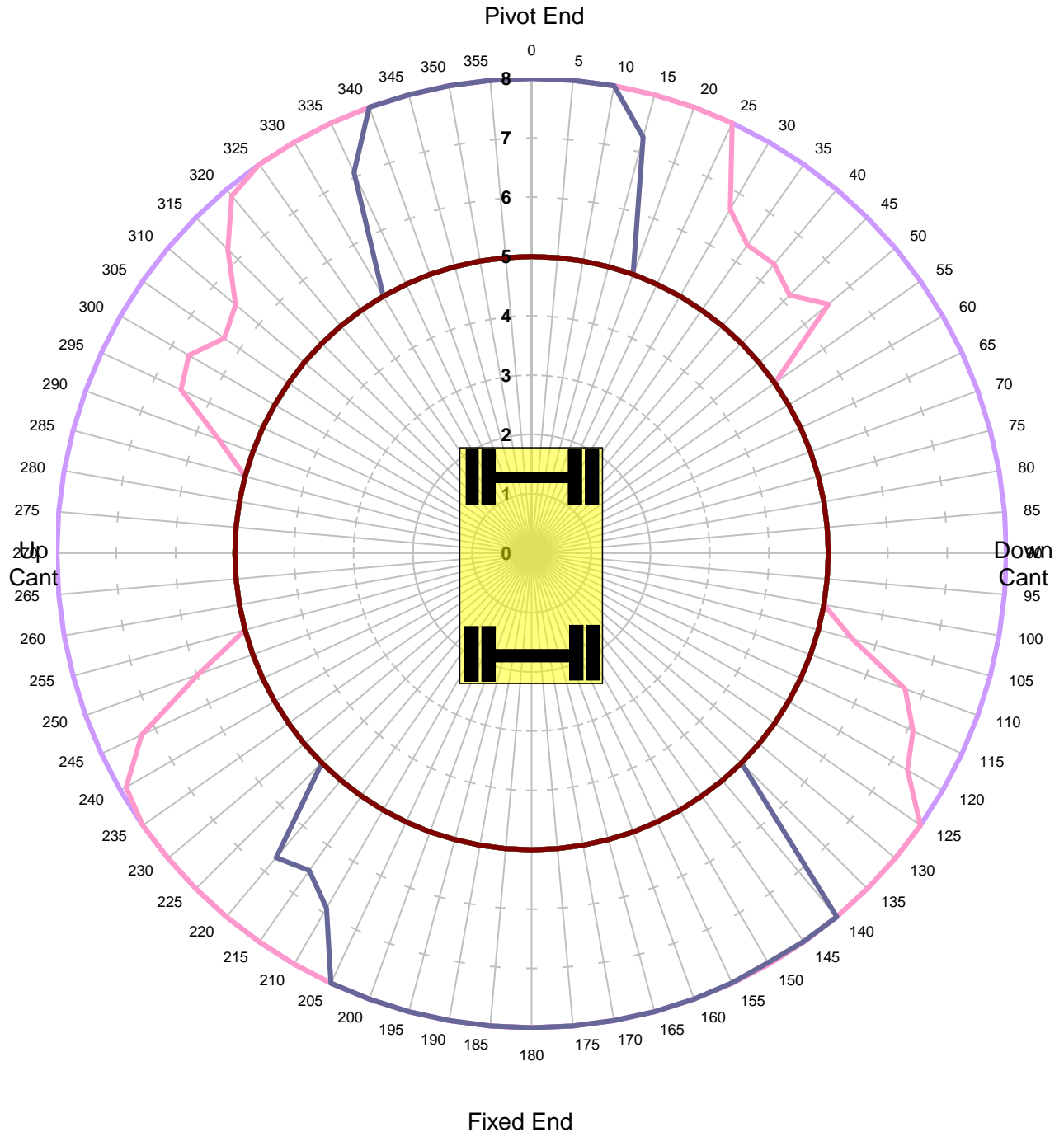

Units in Tonnes

- 1
- 2
- 3
- 4
- 5
- 6
- 7
- 8
- 9
- 10
- 11
- 12
- 13

MACHINE & MODEL:	KOMATSU PW160-7	REFERENCE:	REXQUOTE
SERIAL No:	2325	DATE OF CHART:	7-Feb-2022
EQUIPMENT:	5.15m+2.1m	SAFETY FACTOR:	85.0%
COMMENT:			

KOMATSU PW160-7
Max Capacity Contours of Radius(m) Plots 2.1m Dipper
Gradient 1 in -25 Height 2m Lift QH
Locked Rail Cant 50mm

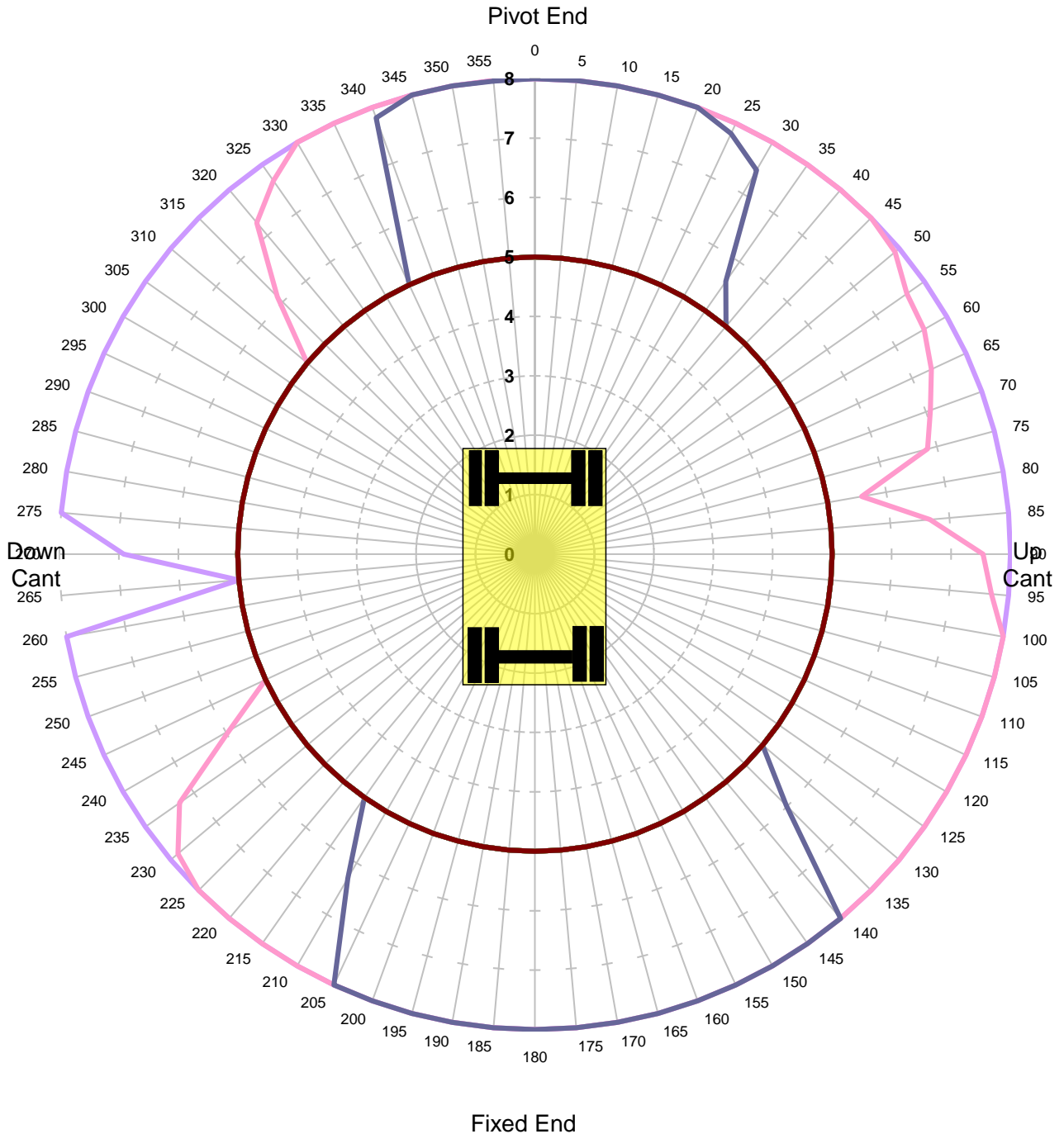

Units in Tonnes

- 1
- 2
- 3
- 4
- 5
- 6
- 7
- 8
- 9
- 10
- 11
- 12
- 13

MACHINE & MODEL:	KOMATSU PW160-7	REFERENCE:	REXQUOTE
SERIAL No:	2325	DATE OF CHART:	7-Feb-2022
EQUIPMENT:	5.15m+2.1m	SAFETY FACTOR:	85.0%
COMMENT:			

KOMATSU PW160-7
Max Capacity Contours of Radius(m) Plots 2.1m Dipper
Gradient 1 in -25 Height 2m Lift QH
Locked Rail Cant 150mm

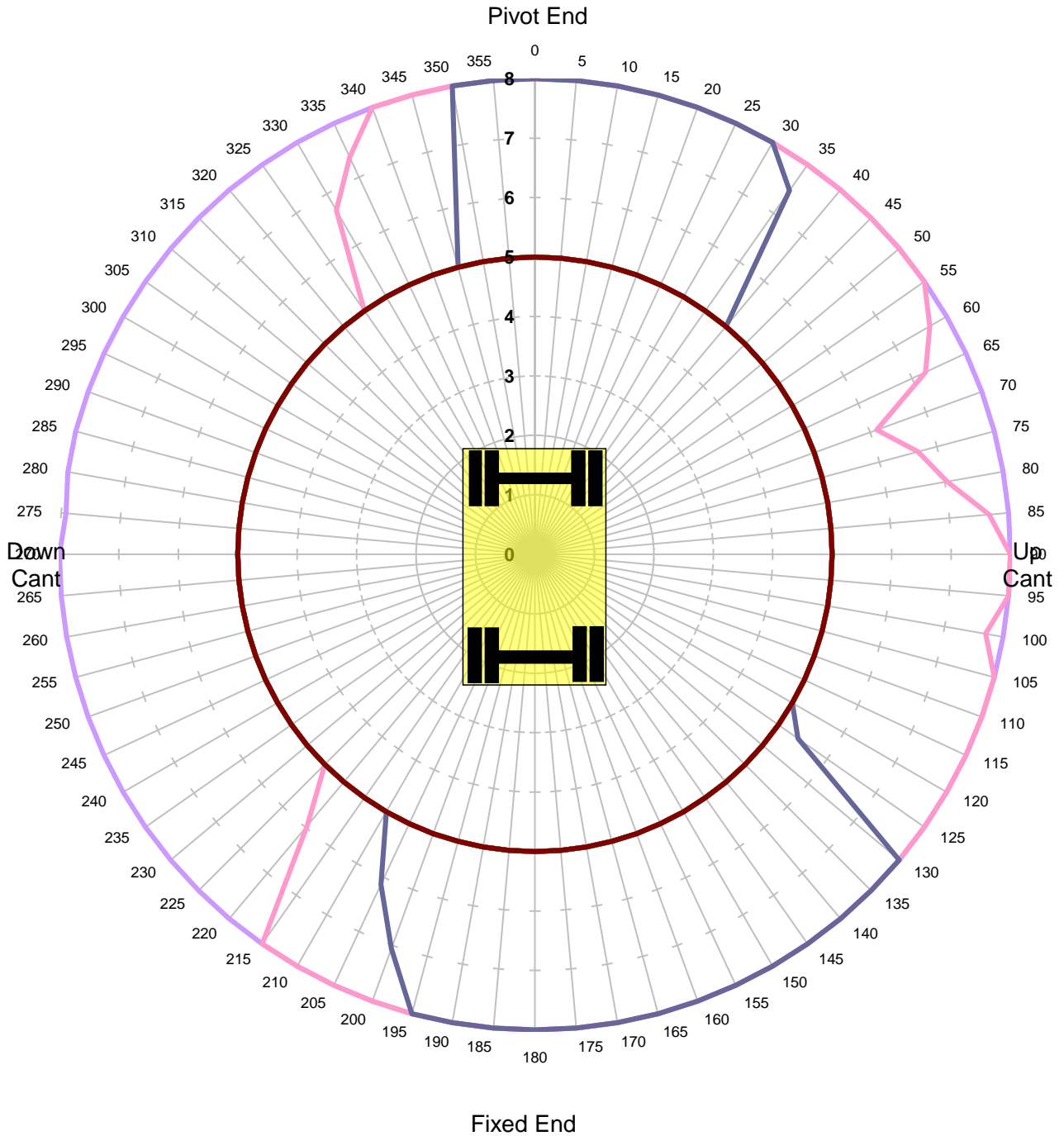

Units in Tonnes

- 1
- 2
- 3
- 4
- 5
- 6
- 7
- 8
- 9
- 10
- 11
- 12
- 13

MACHINE & MODEL:	KOMATSU PW160-7	REFERENCE:	REXQUOTE
SERIAL No:	2325	DATE OF CHART:	7-Feb-2022
EQUIPMENT:	5.15m+2.1m	SAFETY FACTOR:	85.0%
COMMENT:			

KOMATSU PW160-7

**Max Capacity Contours of Radius(m) Plots 2.1m Dipper
Level Ground Height 2m Lift QH
Unlocked Road**

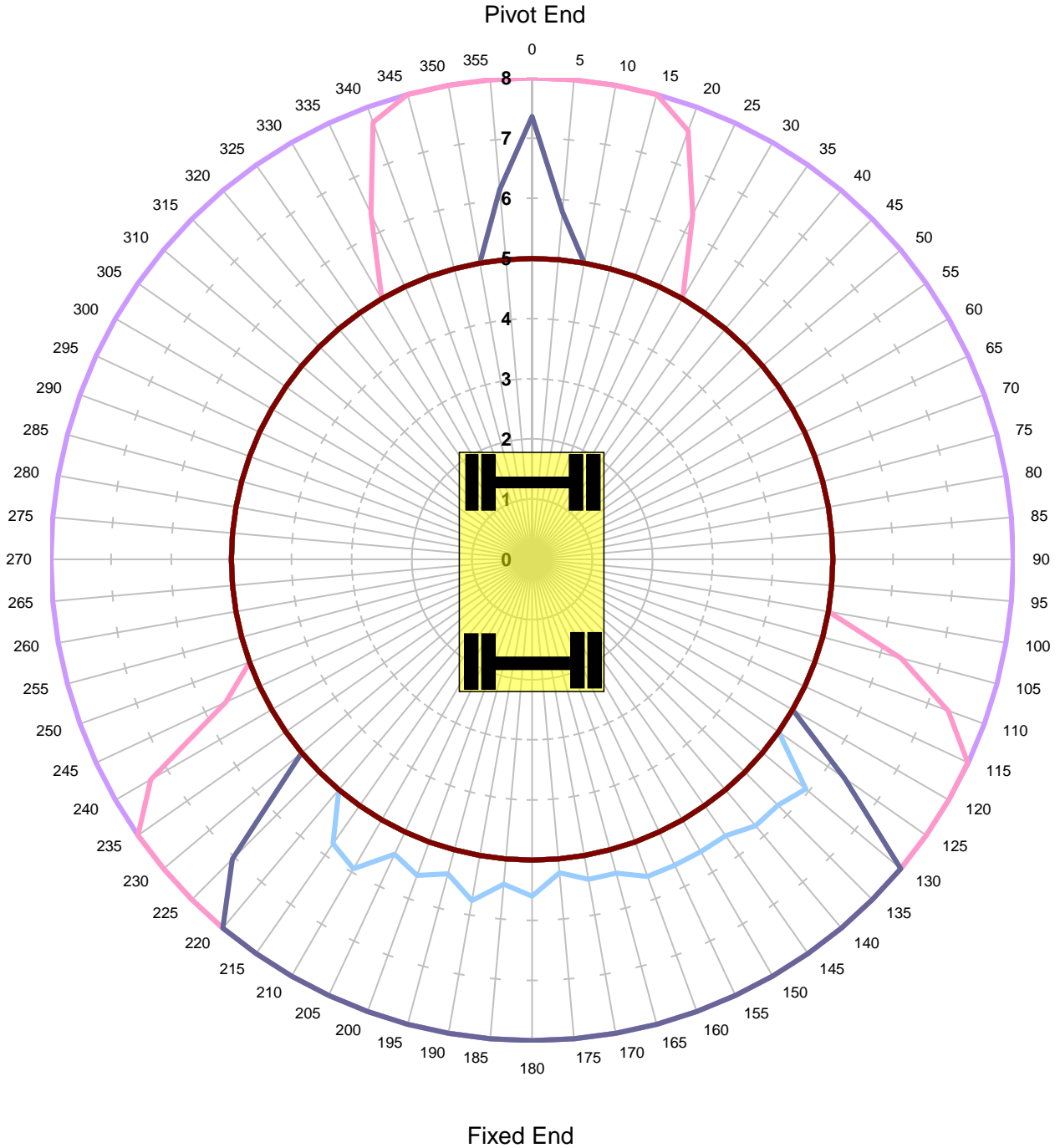

Units in Tonnes

- 1
- 2
- 3
- 4
- 5
- 6
- 7
- 8
- 9
- 10
- 11
- 12
- 13

MACHINE & MODEL:	KOMATSU PW160-7	REFERENCE:	REXQUOTE
SERIAL No:	2325	DATE OF CHART:	7-Feb-2022
EQUIPMENT:	5.15m+2.1m	SAFETY FACTOR:	67.0%
COMMENT:			

KOMATSU PW160-7

**Max Capacity Contours of Radius(m) Plots 2.1m Dipper
Level Ground Height 2m Lift QH
Locked Road**

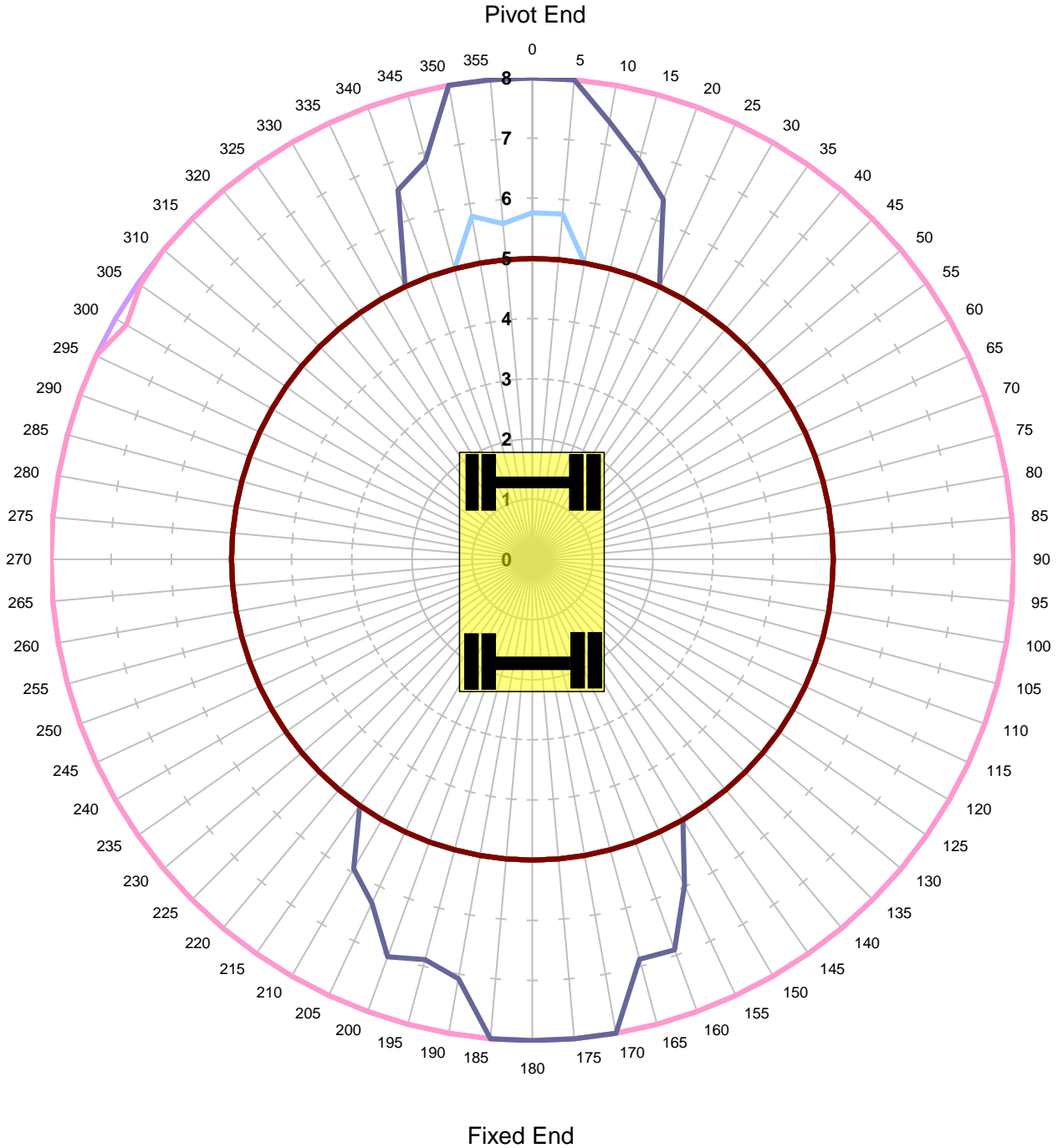

Units in Tonnes

- 1
- 2
- 3
- 4
- 5
- 6
- 7
- 8
- 9
- 10
- 11
- 12
- 13

MACHINE & MODEL:	KOMATSU PW160-7	REFERENCE:	REXQUOTE
SERIAL No:	2325	DATE OF CHART:	7-Feb-2022
EQUIPMENT:	5.15m+2.1m	SAFETY FACTOR:	67.0%
COMMENT:			

KOMATSU PW160-7

**Max Capacity Contours of Radius(m) Plots 2.1m Dipper
Gradient 1 in -25 Height 2m Lift QH**

Unlocked Rail Cant -150mm - Tandem Lift

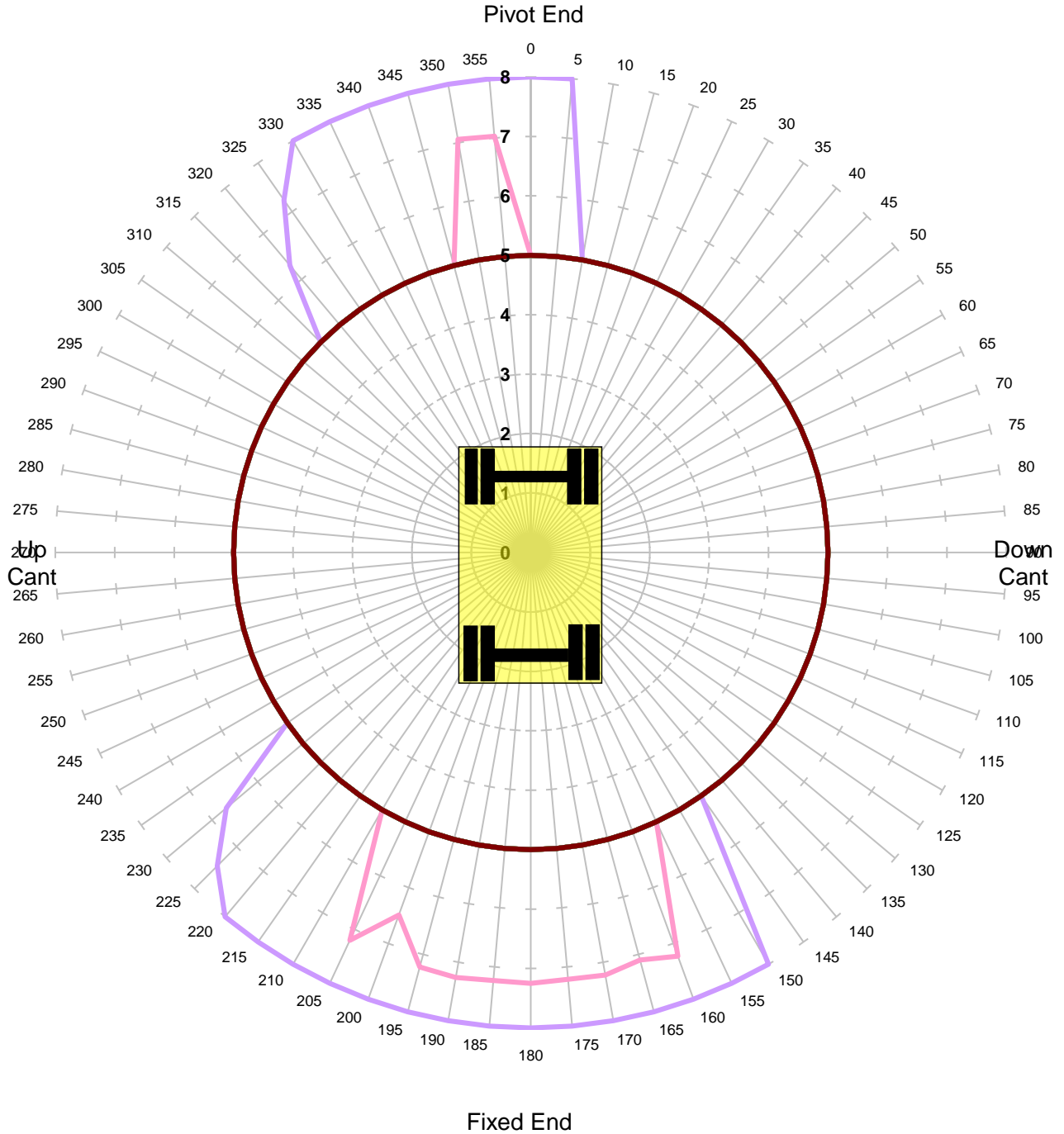

Units in Tonnes

- 1
- 2
- 3
- 4
- 5
- 6
- 7
- 8
- 9
- 10
- 11
- 12
- 13

MACHINE & MODEL:	KOMATSU PW160-7	REFERENCE:	REXQUOTE
SERIAL No:	2325	DATE OF CHART:	7-Feb-2022
EQUIPMENT:	5.15m+2.1m	SAFETY FACTOR:	39.0%
COMMENT:			

KOMATSU PW160-7

**Max Capacity Contours of Radius(m) Plots 2.1m Dipper
Gradient 1 in -25 Height 2m Lift QH**

Unlocked Rail Cant -50mm - Tandem Lift

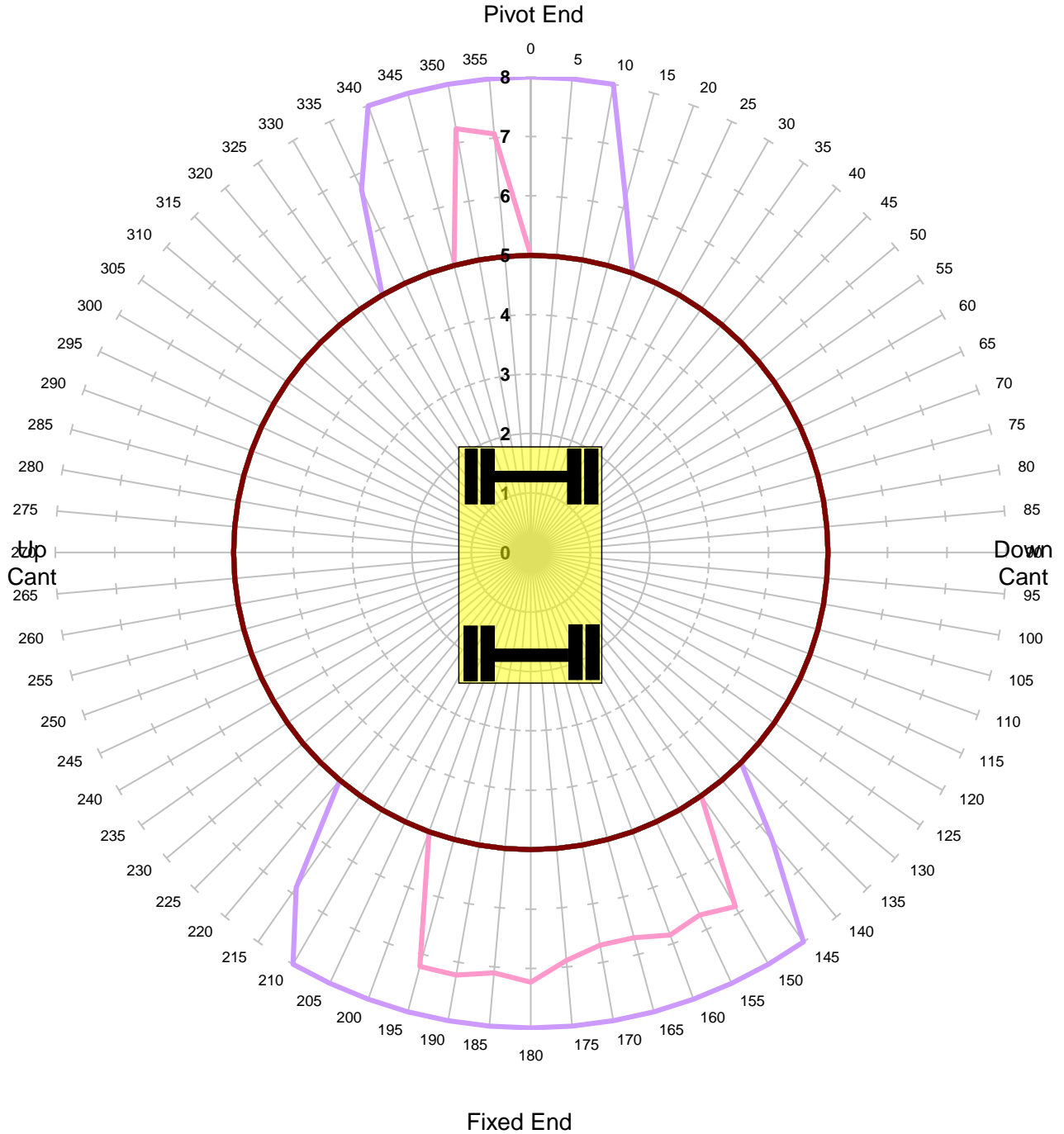

Units in Tonnes

- 1
- 2
- 3
- 4
- 5
- 6
- 7
- 8
- 9
- 10
- 11
- 12
- 13

MACHINE & MODEL:	KOMATSU PW160-7	REFERENCE:	REXQUOTE
SERIAL No:	2325	DATE OF CHART:	7-Feb-2022
EQUIPMENT:	5.15m+2.1m	SAFETY FACTOR:	39.0%
COMMENT:			

KOMATSU PW160-7

**Max Capacity Contours of Radius(m) Plots 2.1m Dipper
Gradient 1 in -25 Height 2m Lift QH**

Unlocked Rail Cant 50mm - Tandem Lift

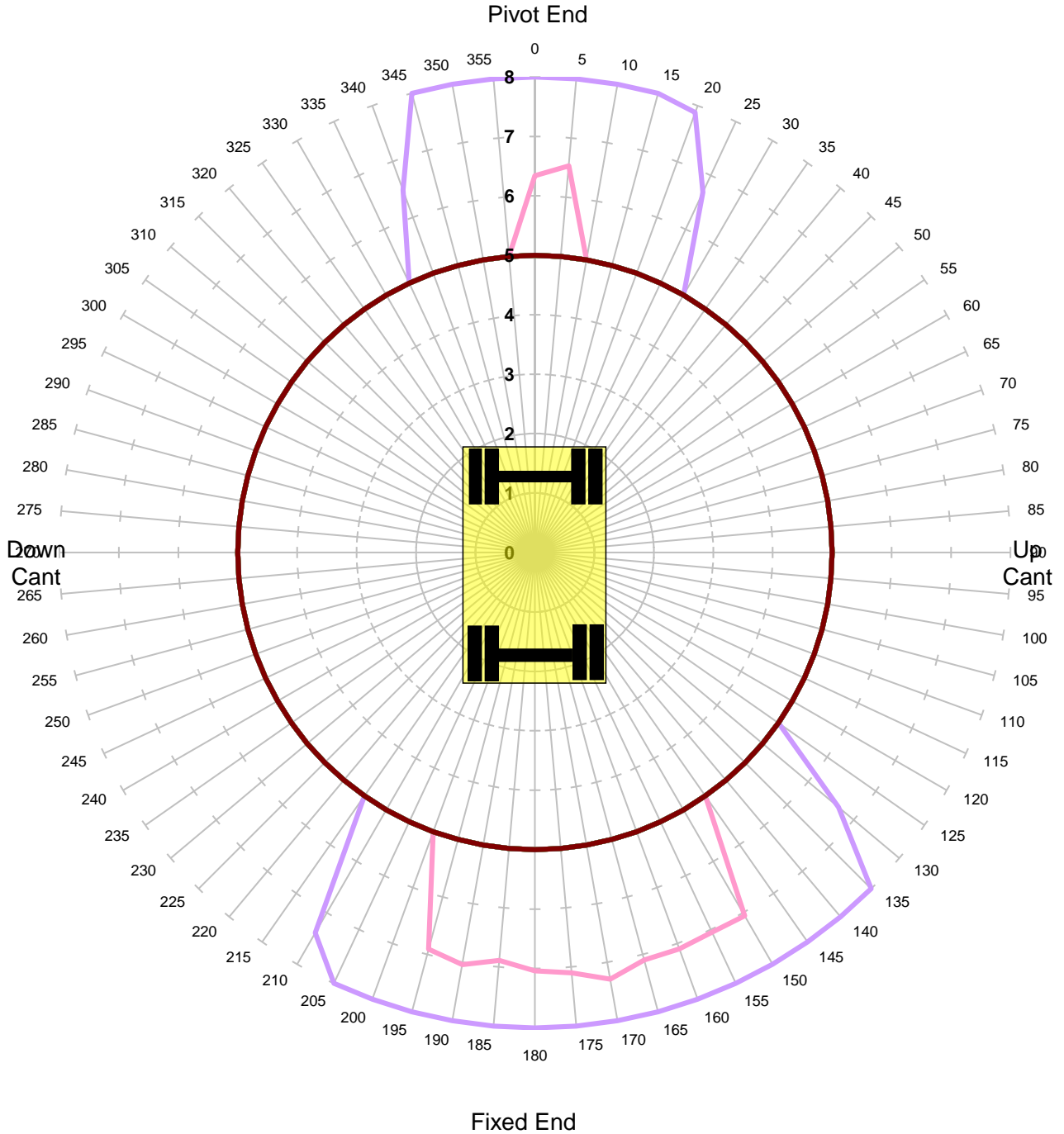

Units in Tonnes

- 1
- 2
- 3
- 4
- 5
- 6
- 7
- 8
- 9
- 10
- 11
- 12
- 13

MACHINE & MODEL:	KOMATSU PW160-7	REFERENCE:	REXQUOTE
SERIAL No:	2325	DATE OF CHART:	7-Feb-2022
EQUIPMENT:	5.15m+2.1m	SAFETY FACTOR:	39.0%
COMMENT:			

KOMATSU PW160-7

**Max Capacity Contours of Radius(m) Plots 2.1m Dipper
Gradient 1 in -25 Height 2m Lift QH**

Unlocked Rail Cant 150mm - Tandem Lift

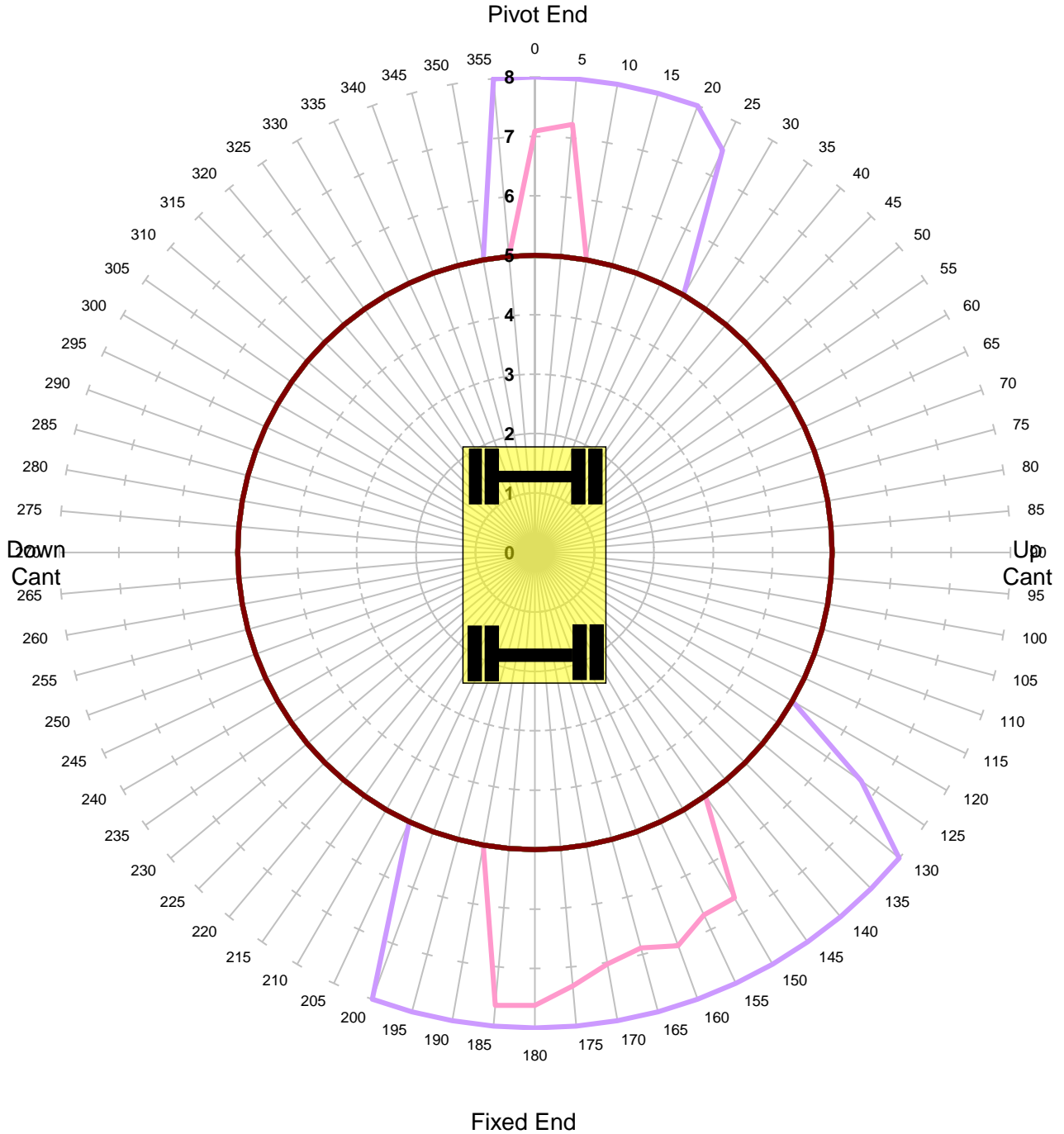

Units in Tonnes

-
-
-
-
-
-
-
-
-
-
-
-
-

MACHINE & MODEL:	KOMATSU PW160-7	REFERENCE:	REXQUOTE
SERIAL No:	2325	DATE OF CHART:	7-Feb-2022
EQUIPMENT:	5.15m+2.1m	SAFETY FACTOR:	39.0%
COMMENT:			

KOMATSU PW160-7

**Max Capacity Contours of Radius(m) Plots 2.1m Dipper
Gradient 1 in -25 Height 2m Lift QH**

Locked Rail Cant -150mm - Tandem Lift

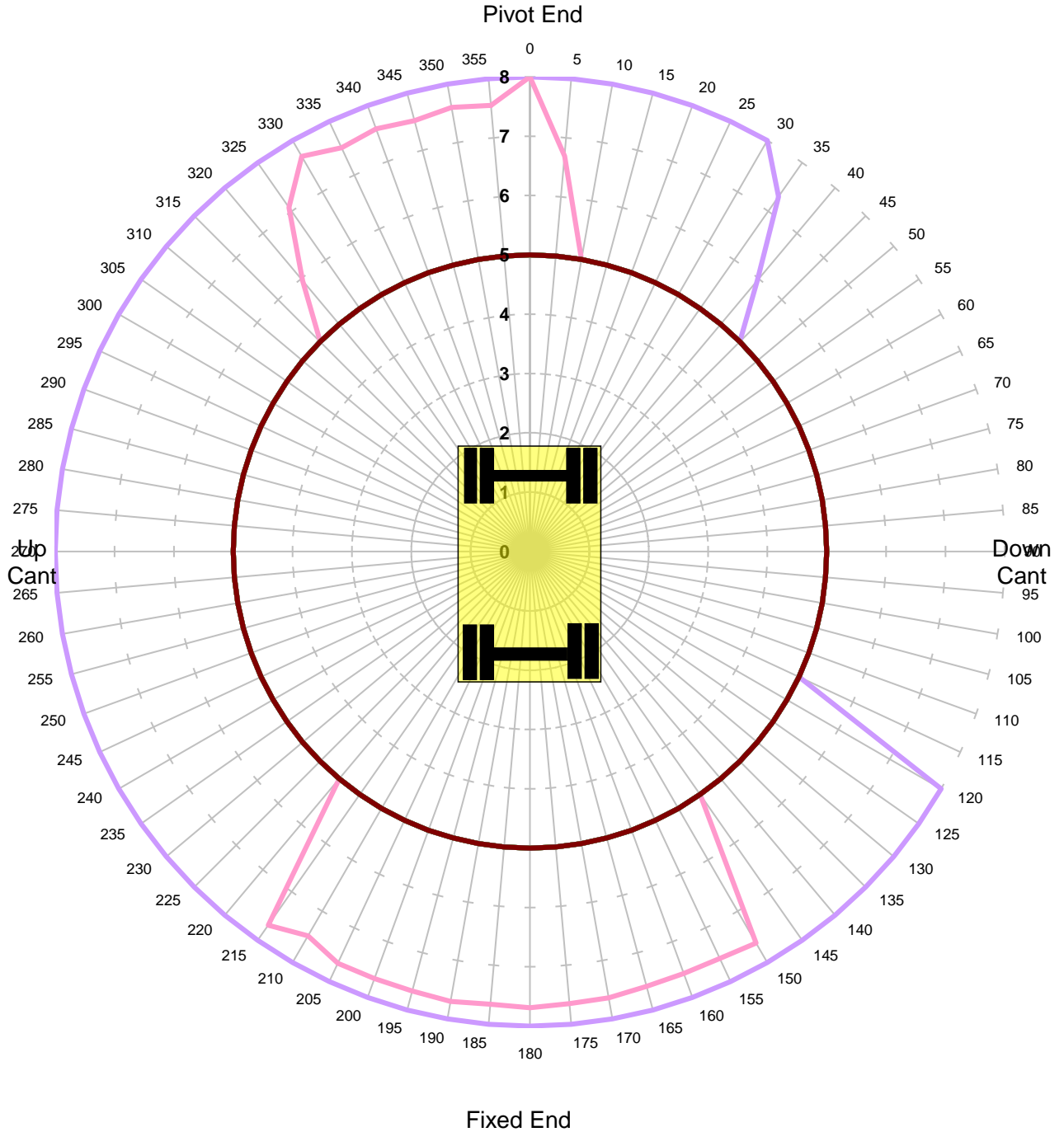

Units in Tonnes

- 1
- 2
- 3
- 4
- 5
- 6
- 7
- 8
- 9
- 10
- 11
- 12
- 13

MACHINE & MODEL:	KOMATSU PW160-7	REFERENCE:	REXQUOTE
SERIAL No:	2325	DATE OF CHART:	7-Feb-2022
EQUIPMENT:	5.15m+2.1m	SAFETY FACTOR:	53.0%
COMMENT:			

KOMATSU PW160-7

**Max Capacity Contours of Radius(m) Plots 2.1m Dipper
Gradient 1 in -25 Height 2m Lift QH**

Locked Rail Cant -50mm - Tandem Lift

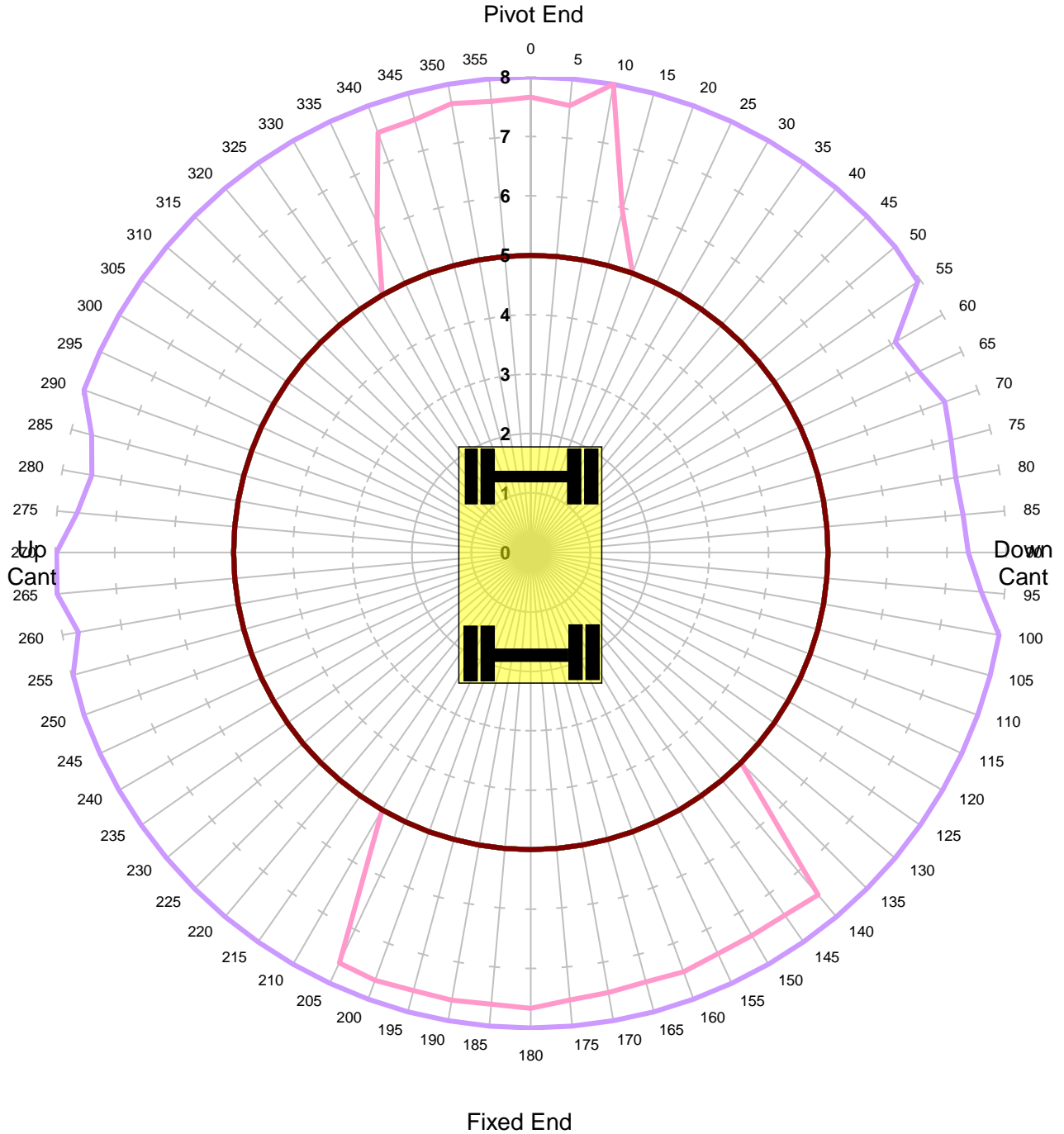

Units in Tonnes

- 1
- 2
- 3
- 4
- 5
- 6
- 7
- 8
- 9
- 10
- 11
- 12
- 13

MACHINE & MODEL:	KOMATSU PW160-7	REFERENCE:	REXQUOTE
SERIAL No:	2325	DATE OF CHART:	7-Feb-2022
EQUIPMENT:	5.15m+2.1m	SAFETY FACTOR:	53.0%
COMMENT:			

KOMATSU PW160-7

**Max Capacity Contours of Radius(m) Plots 2.1m Dipper
Gradient 1 in -25 Height 2m Lift QH**

Locked Rail Cant 50mm - Tandem Lift

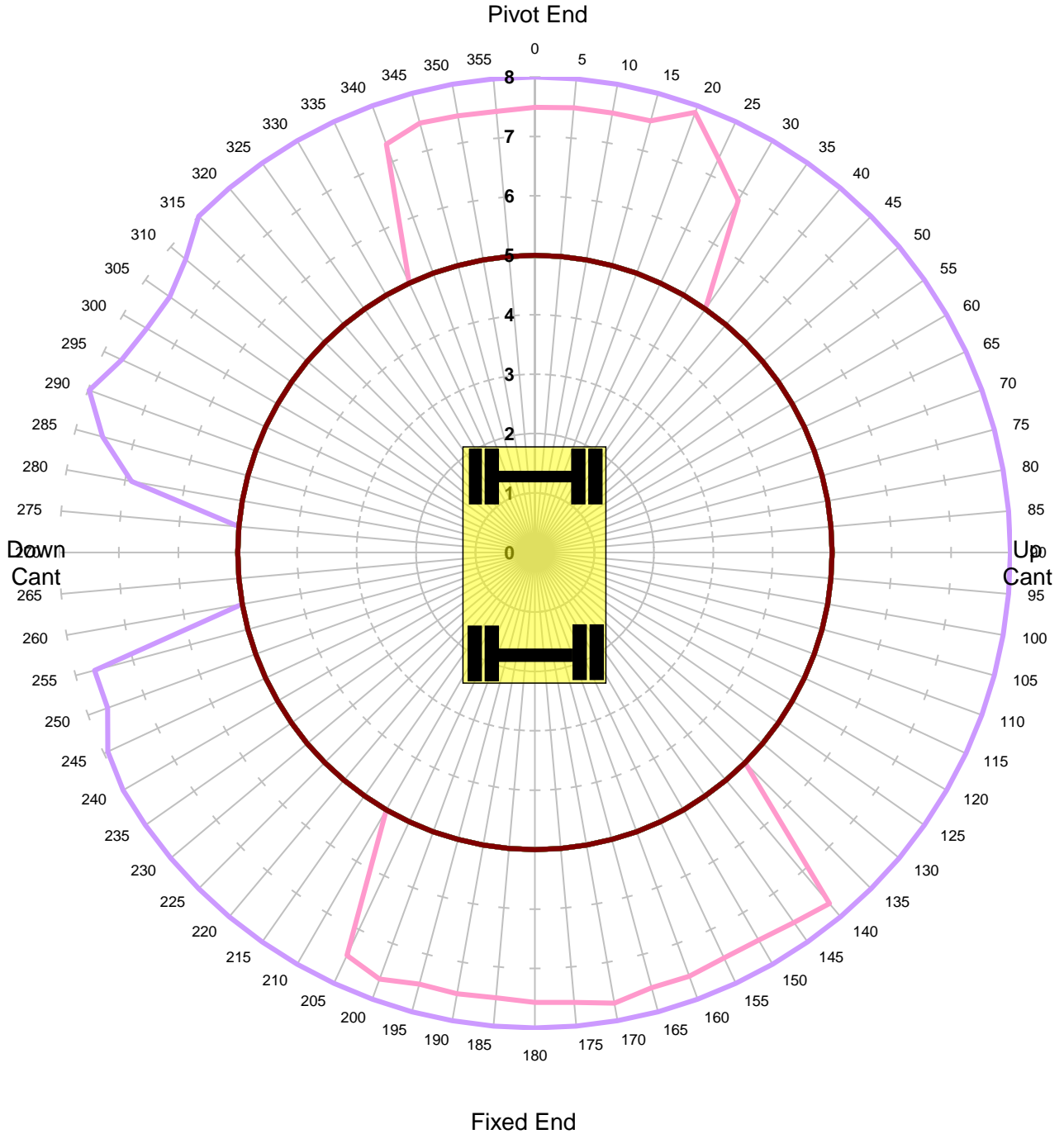

Units in Tonnes

- 1
- 2
- 3
- 4
- 5
- 6
- 7
- 8
- 9
- 10
- 11
- 12
- 13

MACHINE & MODEL:	KOMATSU PW160-7	REFERENCE:	REXQUOTE
SERIAL No:	2325	DATE OF CHART:	7-Feb-2022
EQUIPMENT:	5.15m+2.1m	SAFETY FACTOR:	53.0%
COMMENT:			

KOMATSU PW160-7

**Max Capacity Contours of Radius(m) Plots 2.1m Dipper
Gradient 1 in -25 Height 2m Lift QH**

Locked Rail Cant 150mm - Tandem Lift

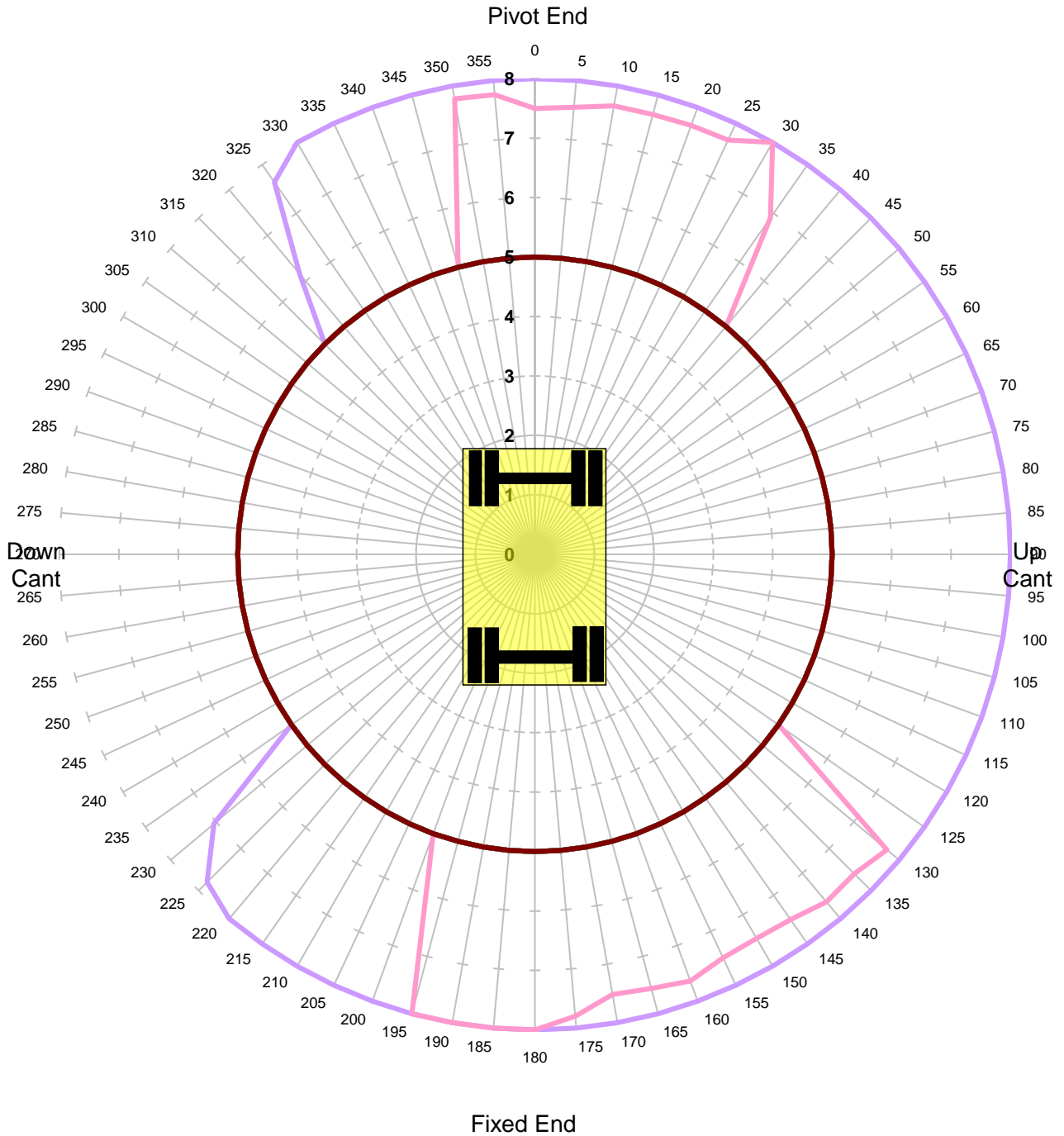

Units in Tonnes

-
 1
 -
 2
 -
 3
 -
 4
 -
 5
 -
 6
 -
 7
 -
 8
 -
 9
 -
 10
 -
 11
 -
 12
 -
 13

MACHINE & MODEL:	KOMATSU PW160-7	REFERENCE:	REXQUOTE
SERIAL No:	2325	DATE OF CHART:	7-Feb-2022
EQUIPMENT:	5.15m+2.1m	SAFETY FACTOR:	53.0%
COMMENT:			

KOMATSU PW160-7

**Max Capacity Contours of Radius(m) Plots 2.1m Dipper
Level Ground Height 2m Lift QH
Unlocked Road - Tandem Lift**

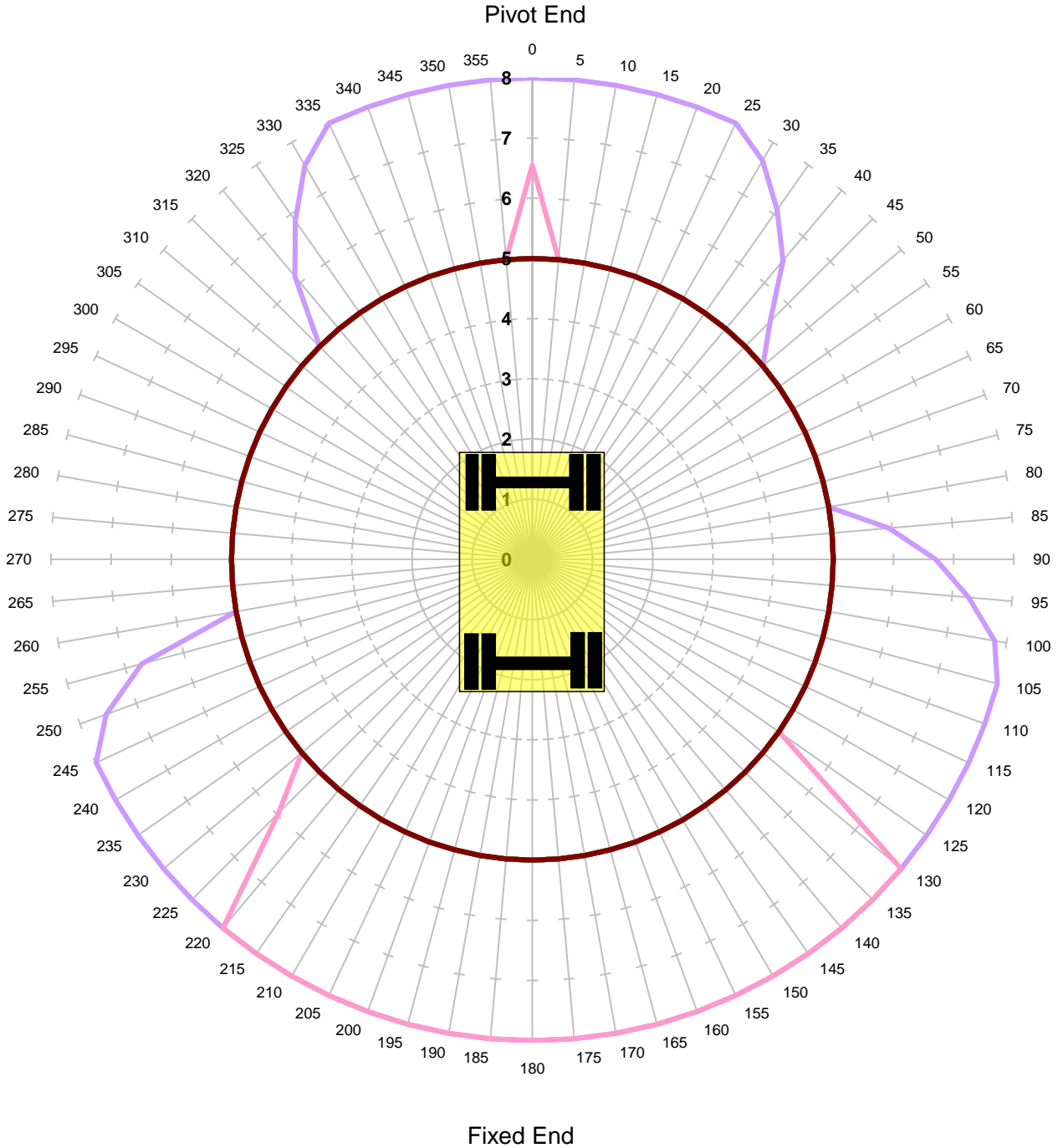

Units in Tonnes

- 1
- 2
- 3
- 4
- 5
- 6
- 7
- 8
- 9
- 10
- 11
- 12
- 13

MACHINE & MODEL:	KOMATSU PW160-7	REFERENCE:	REXQUOTE
SERIAL No:	2325	DATE OF CHART:	7-Feb-2022
EQUIPMENT:	5.15m+2.1m	SAFETY FACTOR:	42.0%
COMMENT:			

KOMATSU PW160-7
Max Capacity Contours of Radius(m) Plots 2.1m Dipper
Level Ground Height 2m Lift QH
Locked Road - Tandem Lift

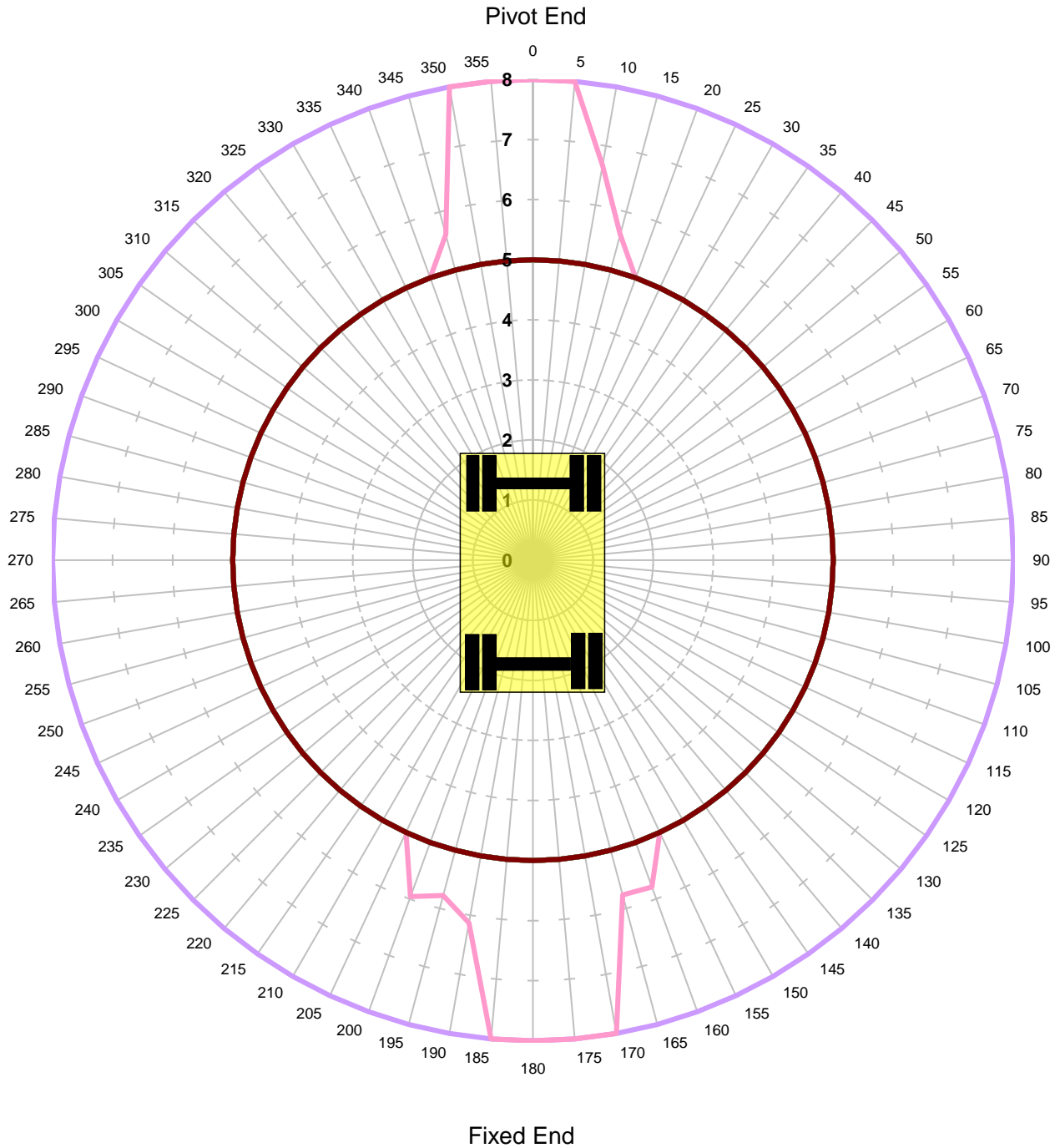

Units in Tonnes

- 1
- 2
- 3
- 4
- 5
- 6
- 7
- 8
- 9
- 10
- 11
- 12
- 13

MACHINE & MODEL:	KOMATSU PW160-7	REFERENCE:	REXQUOTE
SERIAL No:	2325	DATE OF CHART:	7-Feb-2022
EQUIPMENT:	5.15m+2.1m	SAFETY FACTOR:	42.0%
COMMENT:			