

## Colmar T10000FS

**Max Capacity Contours of Radius(m) Plots 2.1m Dipper Cwt In  
Gradient 1 in -25 Height 2m Lift BP**

**Unlocked Rail Cant -150mm**

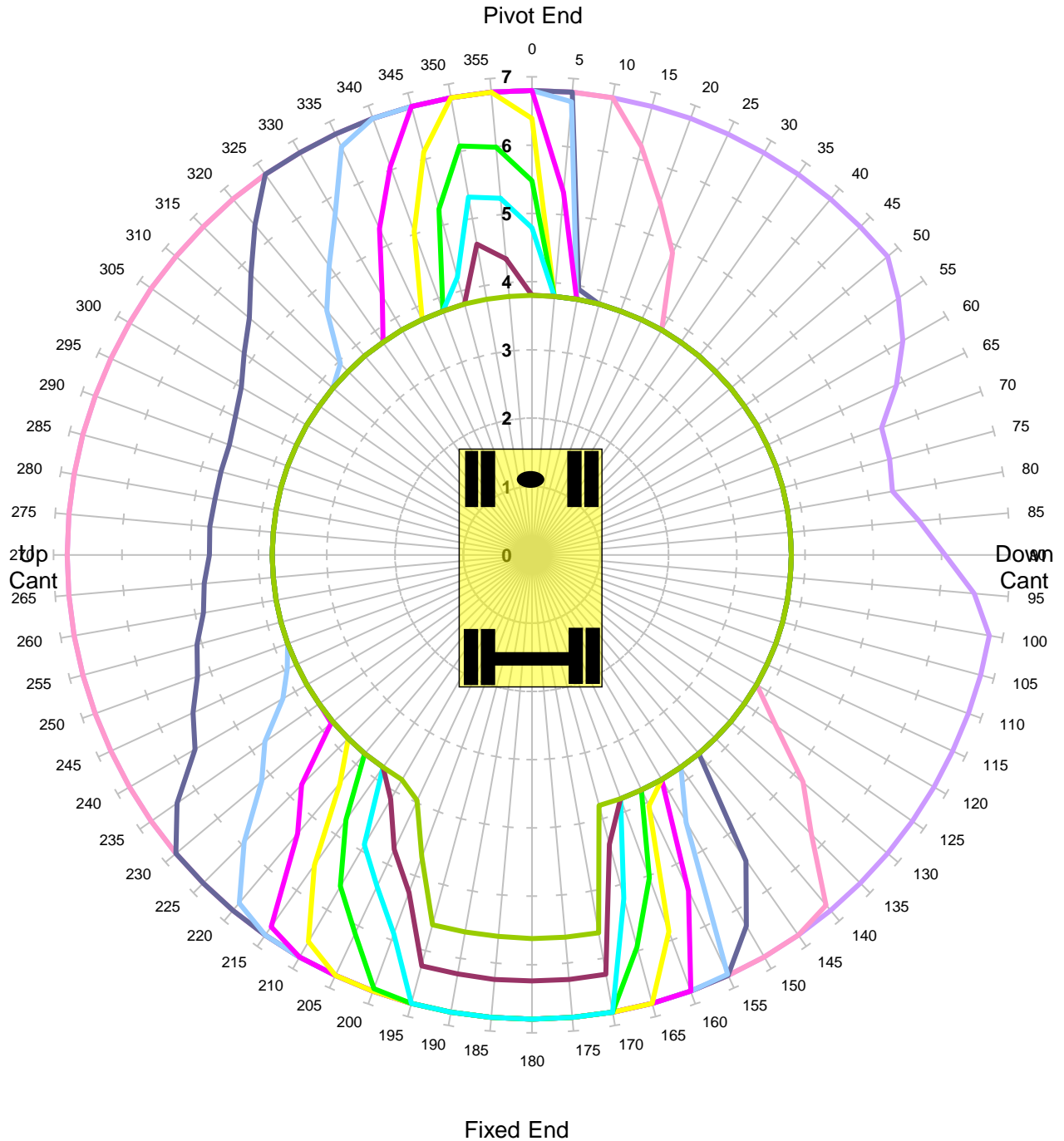

Units in Tonnes

- 1  
 — 2  
 — 3  
 — 4  
 — 5  
 — 6  
 — 7  
 — 8  
 — 9  
 — 10

<b>MACHINE &amp; MODEL:</b>	Colmar T10000FS	<b>REFERENCE:</b>	Dipper Extends by 1000mm
<b>SERIAL No:</b>	8216	<b>DATE OF CHART:</b>	20-May-2019
<b>EQUIPMENT:</b>	4.08m + 2.10m	<b>SAFETY FACTOR:</b>	67.0%
<b>COMMENT:</b>			

**Colmar T10000FS**  
**Max Capacity Contours of Radius(m) Plots 2.1m Dipper Cwt In**  
**Gradient 1 in -25 Height 2m Lift BP**  
**Unlocked Rail Cant -50mm**

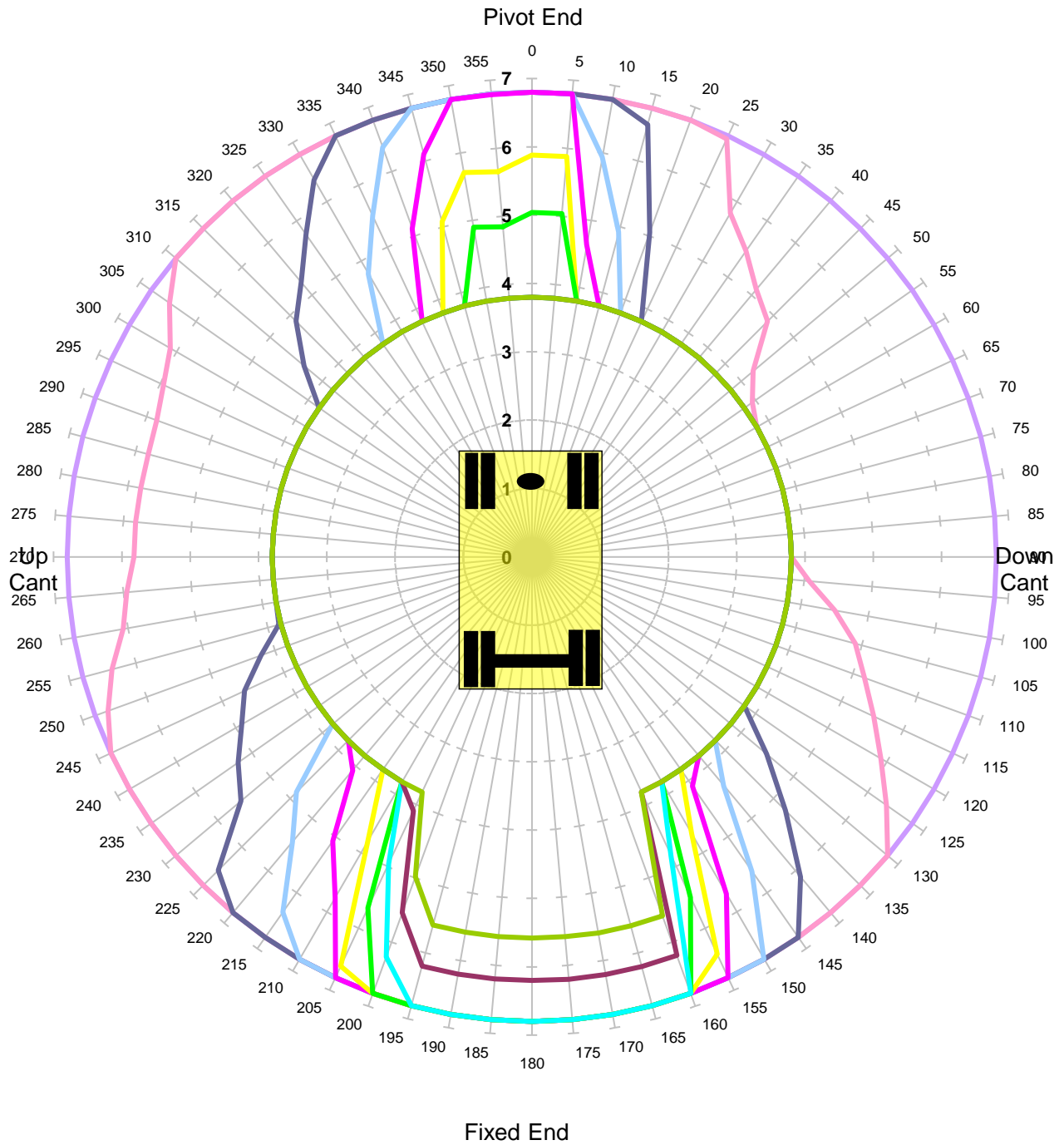

Units in Tonnes  
 1 2 3 4 5 6 7 8 9 10

<b>MACHINE &amp; MODEL:</b>	Colmar T10000FS	<b>REFERENCE:</b>	Dipper Extends by 1000mm
<b>SERIAL No:</b>	8216	<b>DATE OF CHART:</b>	20-May-2019
<b>EQUIPMENT:</b>	4.08m + 2.10m	<b>SAFETY FACTOR:</b>	67.0%
<b>COMMENT:</b>			

**Colmar T10000FS**  
**Max Capacity Contours of Radius(m) Plots 2.1m Dipper Cwt In**  
**Gradient 1 in -25 Height 2m Lift BP**  
**Unlocked Rail Cant 50mm**

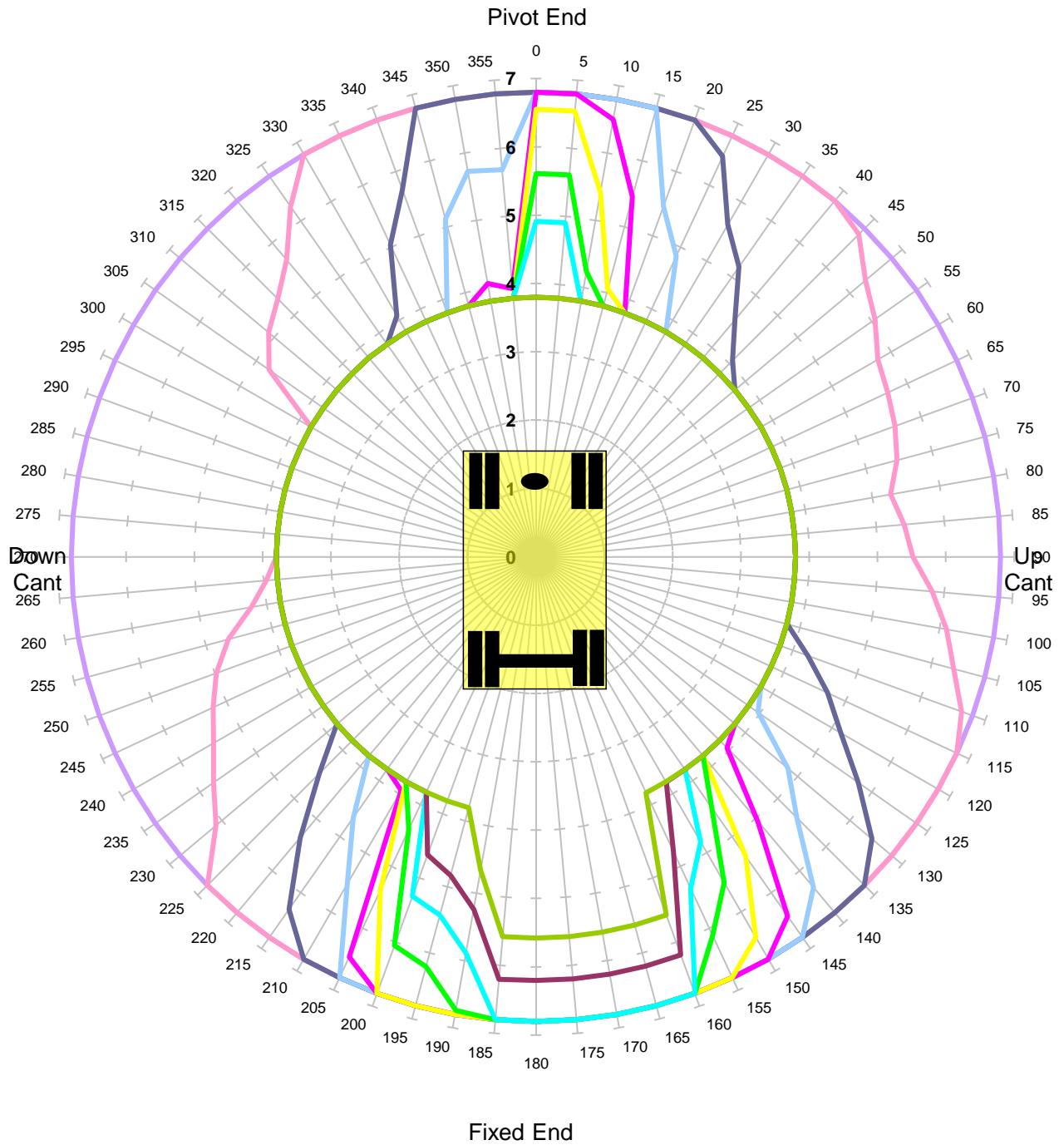

Units in Tonnes  
 1 2 3 4 5 6 7 8 9 10

<b>MACHINE &amp; MODEL:</b>	Colmar T10000FS	<b>REFERENCE:</b>	Dipper Extends by 1000mm
<b>SERIAL No:</b>	8216	<b>DATE OF CHART:</b>	20-May-2019
<b>EQUIPMENT:</b>	4.08m + 2.10m	<b>SAFETY FACTOR:</b>	67.0%
<b>COMMENT:</b>			

## Colmar T10000FS

**Max Capacity Contours of Radius(m) Plots 2.1m Dipper Cwt In  
Gradient 1 in -25 Height 2m Lift BP**

**Unlocked Rail Cant 150mm**

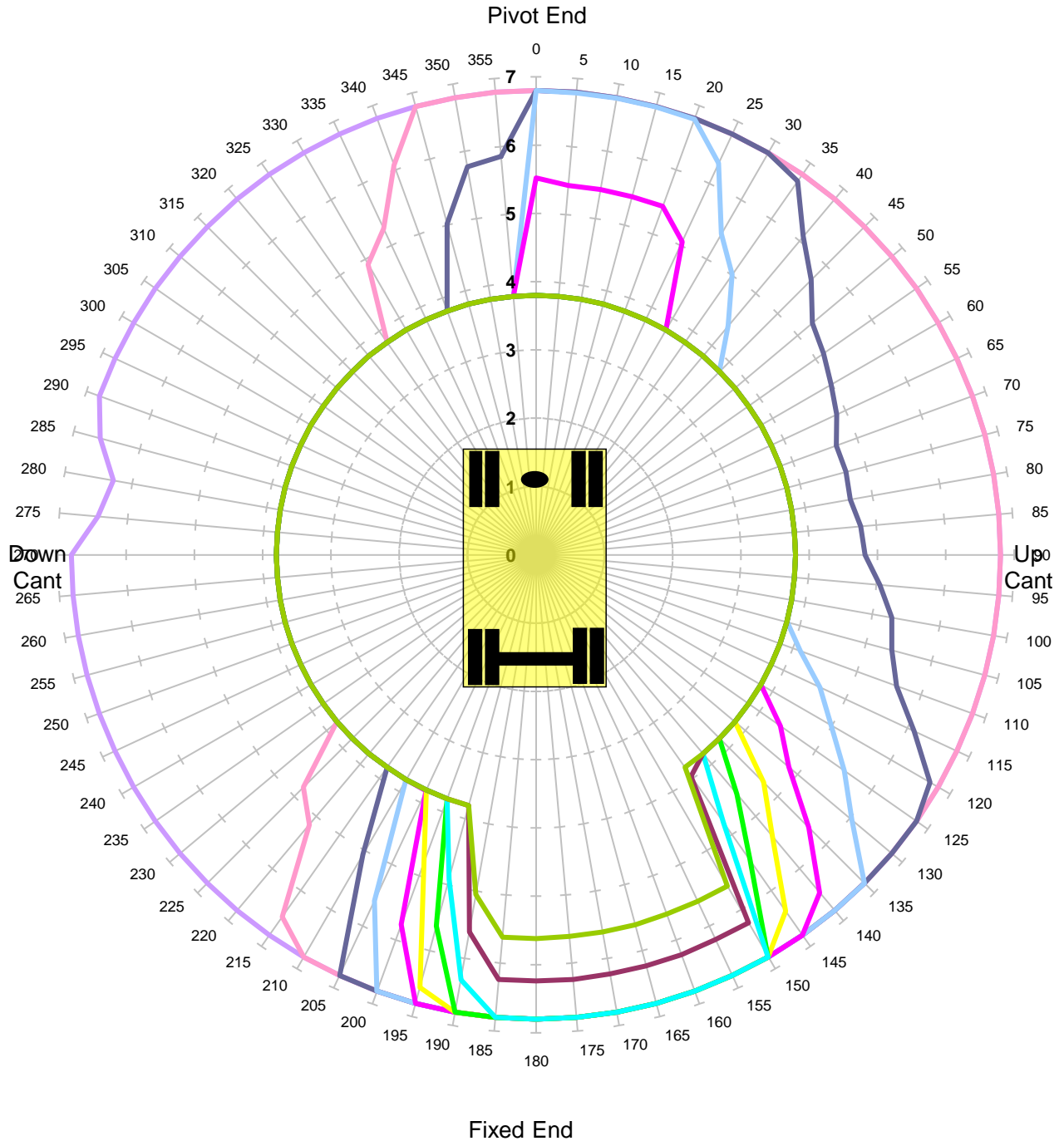

Units in Tonnes

— 1   
 — 2   
 — 3   
 — 4   
 — 5   
 — 6   
 — 7   
 — 8   
 — 9   
 — 10

<b>MACHINE &amp; MODEL:</b>	Colmar T10000FS	<b>REFERENCE:</b>	Dipper Extends by 1000mm
<b>SERIAL No:</b>	8216	<b>DATE OF CHART:</b>	20-May-2019
<b>EQUIPMENT:</b>	4.08m + 2.10m	<b>SAFETY FACTOR:</b>	67.0%
<b>COMMENT:</b>			

## Colmar T10000FS

**Max Capacity Contours of Radius(m) Plots 2.1m Dipper Cwt In  
Gradient 1 in -25 Height 2m Lift BP**

**Locked Rail Cant -150mm**

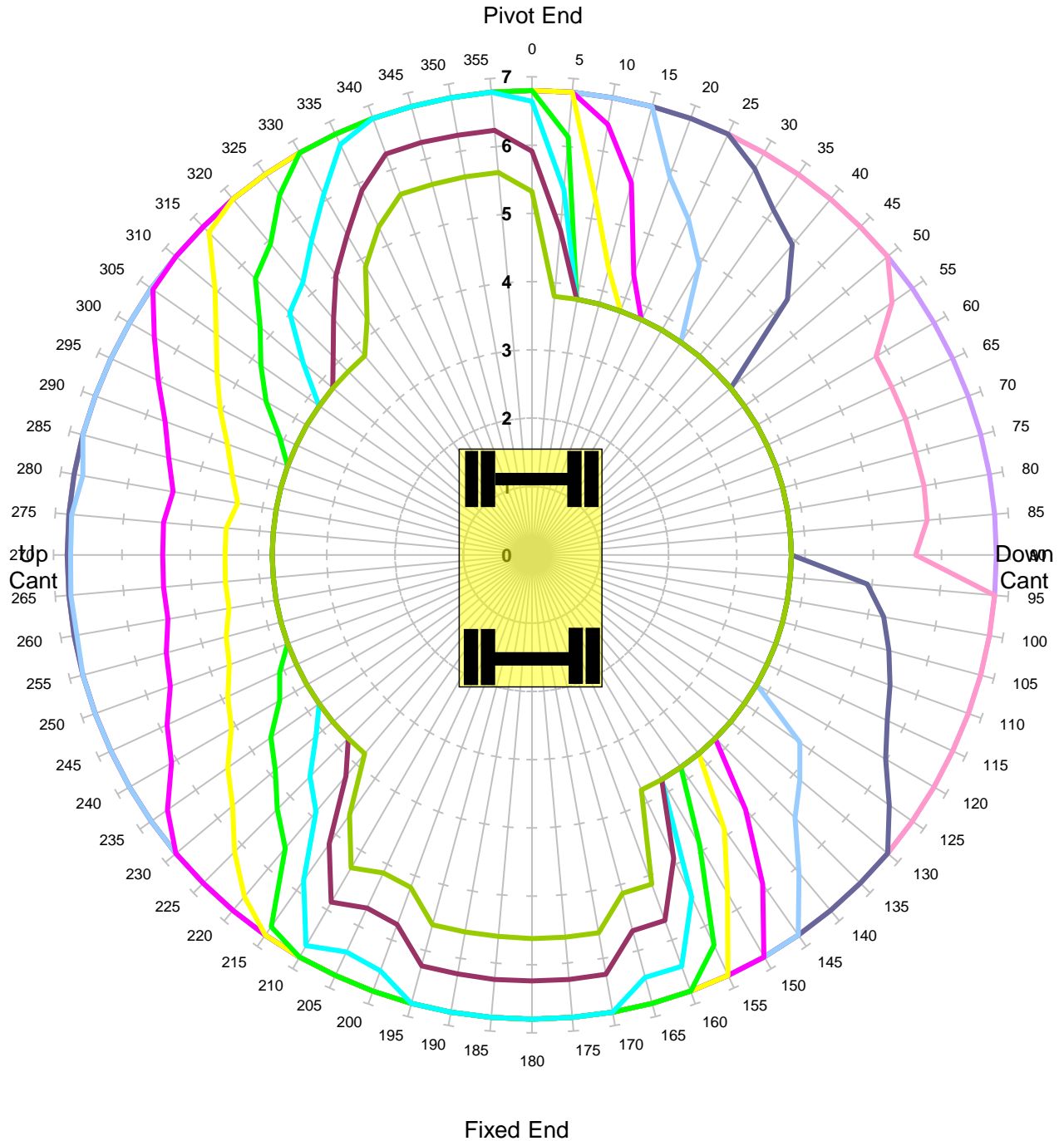

Units in Tonnes

- 1   
 — 2   
 — 3   
 — 4   
 — 5   
 — 6   
 — 7   
 — 8   
 — 9   
 — 10

<b>MACHINE &amp; MODEL:</b>	Colmar T10000FS	<b>REFERENCE:</b>	Dipper Extends by 1000mm
<b>SERIAL No:</b>	8216	<b>DATE OF CHART:</b>	20-May-2019
<b>EQUIPMENT:</b>	4.08m + 2.10m	<b>SAFETY FACTOR:</b>	90.0%
<b>COMMENT:</b>			

**Colmar T10000FS**  
**Max Capacity Contours of Radius(m) Plots 2.1m Dipper Cwt In**  
**Gradient 1 in -25 Height 2m Lift BP**  
**Locked Rail Cant -50mm**

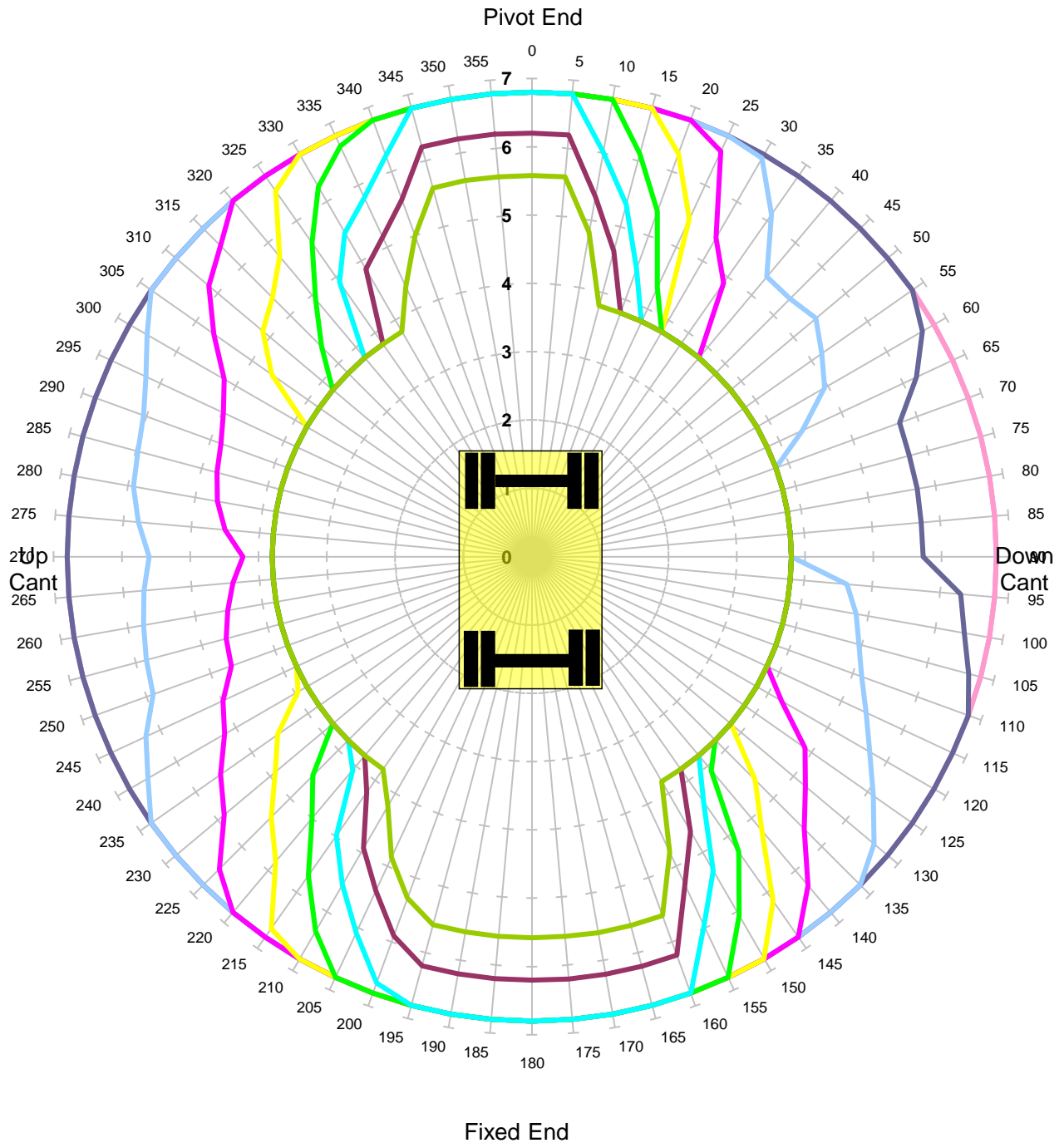

Units in Tonnes

- 1
- 2
- 3
- 4
- 5
- 6
- 7
- 8
- 9
- 10

<b>MACHINE &amp; MODEL:</b>	Colmar T10000FS	<b>REFERENCE:</b>	Dipper Extends by 1000mm
<b>SERIAL No:</b>	8216	<b>DATE OF CHART:</b>	20-May-2019
<b>EQUIPMENT:</b>	4.08m + 2.10m	<b>SAFETY FACTOR:</b>	90.0%
<b>COMMENT:</b>			



**Colmar T10000FS**  
**Max Capacity Contours of Radius(m) Plots 2.1m Dipper Cwt In**  
**Gradient 1 in -25 Height 2m Lift BP**  
**Locked Rail Cant 50mm**

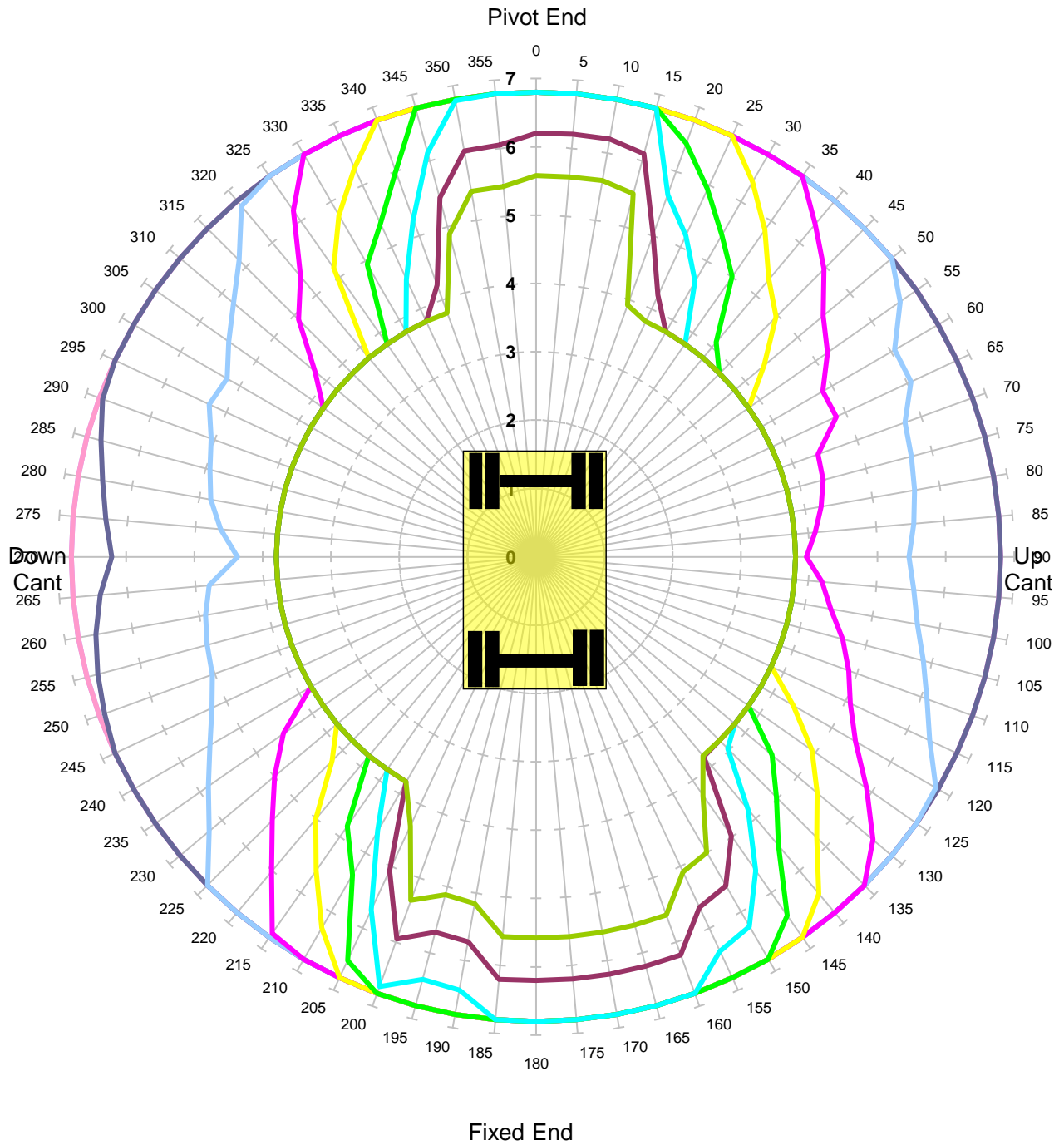

Units in Tonnes

- 1 2 3 4 5 6 7 8 9 10

<b>MACHINE &amp; MODEL:</b>	Colmar T10000FS	<b>REFERENCE:</b>	Dipper Extends by 1000mm
<b>SERIAL No:</b>	8216	<b>DATE OF CHART:</b>	20-May-2019
<b>EQUIPMENT:</b>	4.08m + 2.10m	<b>SAFETY FACTOR:</b>	90.0%
<b>COMMENT:</b>			

**Colmar T10000FS**  
**Max Capacity Contours of Radius(m) Plots 2.1m Dipper Cwt In**  
**Gradient 1 in -25 Height 2m Lift BP**  
**Locked Rail Cant 150mm**

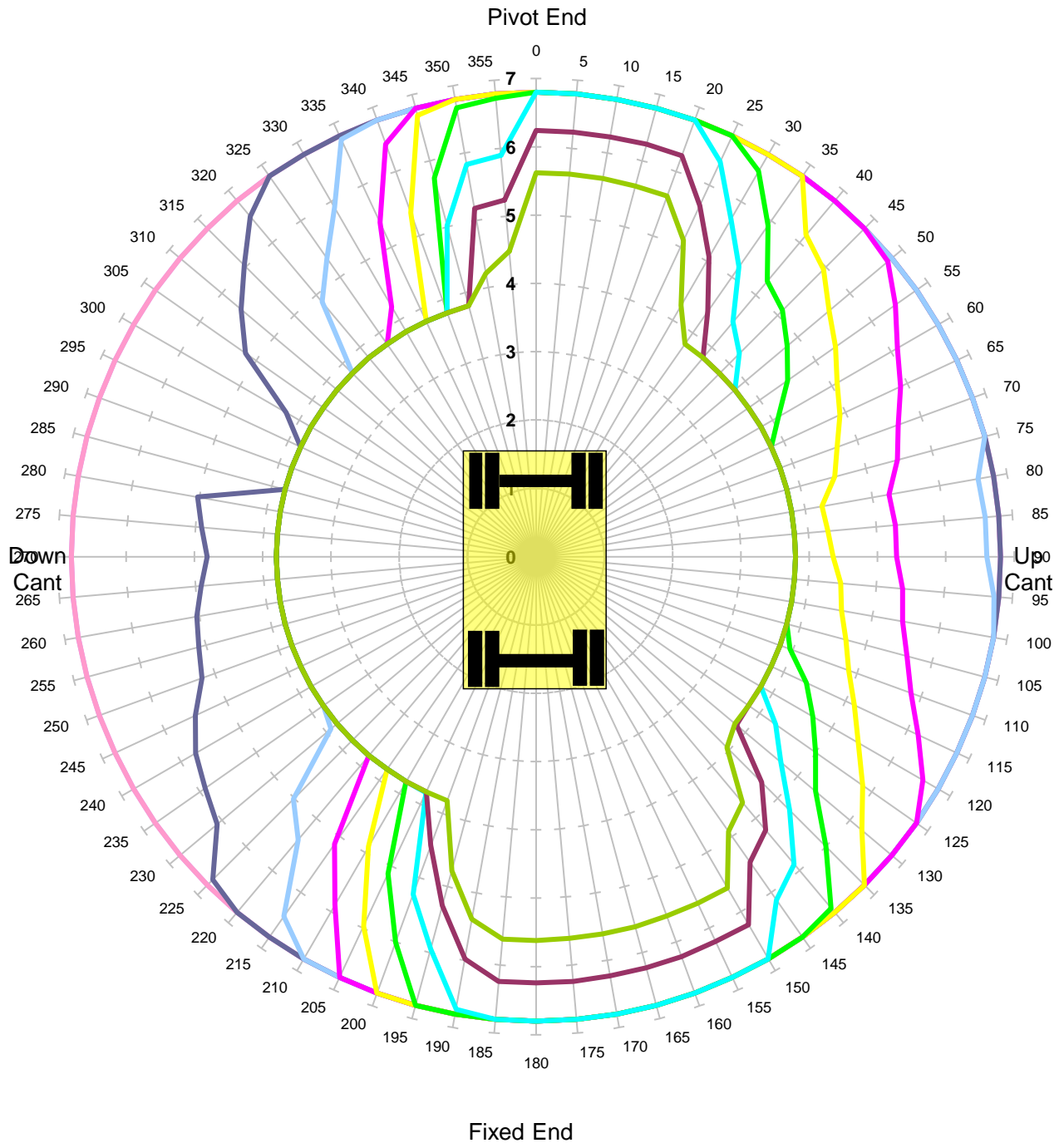

Units in Tonnes

- 1  
 — 2  
 — 3  
 — 4  
 — 5  
 — 6  
 — 7  
 — 8  
 — 9  
 — 10

<b>MACHINE &amp; MODEL:</b>	Colmar T10000FS	<b>REFERENCE:</b>	Dipper Extends by 1000mm
<b>SERIAL No:</b>	8216	<b>DATE OF CHART:</b>	20-May-2019
<b>EQUIPMENT:</b>	4.08m + 2.10m	<b>SAFETY FACTOR:</b>	90.0%
<b>COMMENT:</b>			



## Colmar T10000FS

**Max Capacity Contours of Radius(m) Plots 2.1m Dipper Cwt In  
Level Ground Height 2m Lift BP  
Unlocked Road**

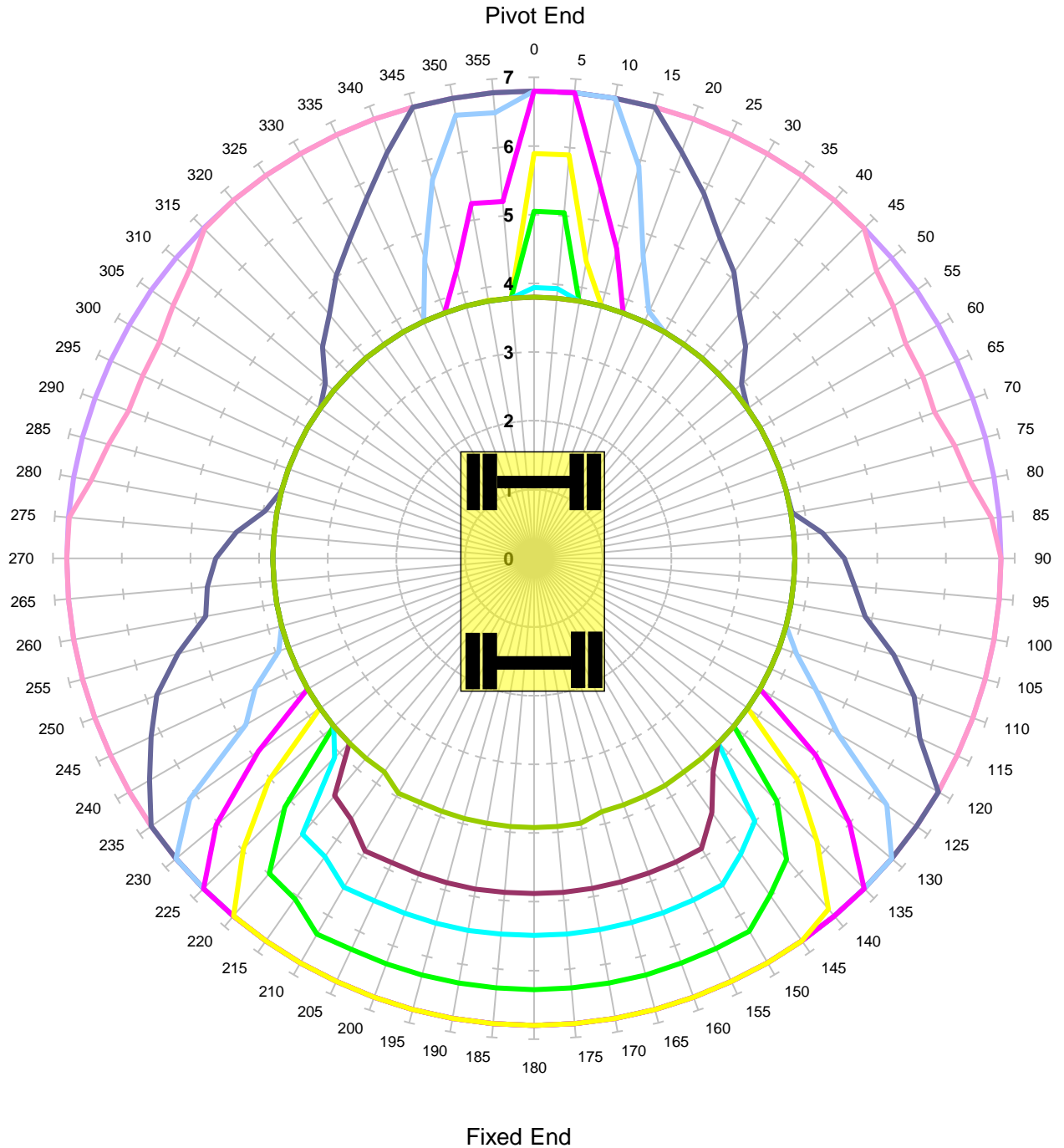

Units in Tonnes

- 1   
 — 2   
 — 3   
 — 4   
 — 5   
 — 6   
 — 7   
 — 8   
 — 9   
 — 10

<b>MACHINE &amp; MODEL:</b>	Colmar T10000FS	<b>REFERENCE:</b>	Dipper Extends by 1000mm
<b>SERIAL No:</b>	8216	<b>DATE OF CHART:</b>	20-May-2019
<b>EQUIPMENT:</b>	4.08m + 2.10m	<b>SAFETY FACTOR:</b>	71.0%
<b>COMMENT:</b>			

## Colmar T10000FS

**Max Capacity Contours of Radius(m) Plots 2.1m Dipper Cwt In  
Level Ground Height 2m Lift BP  
Locked Road**

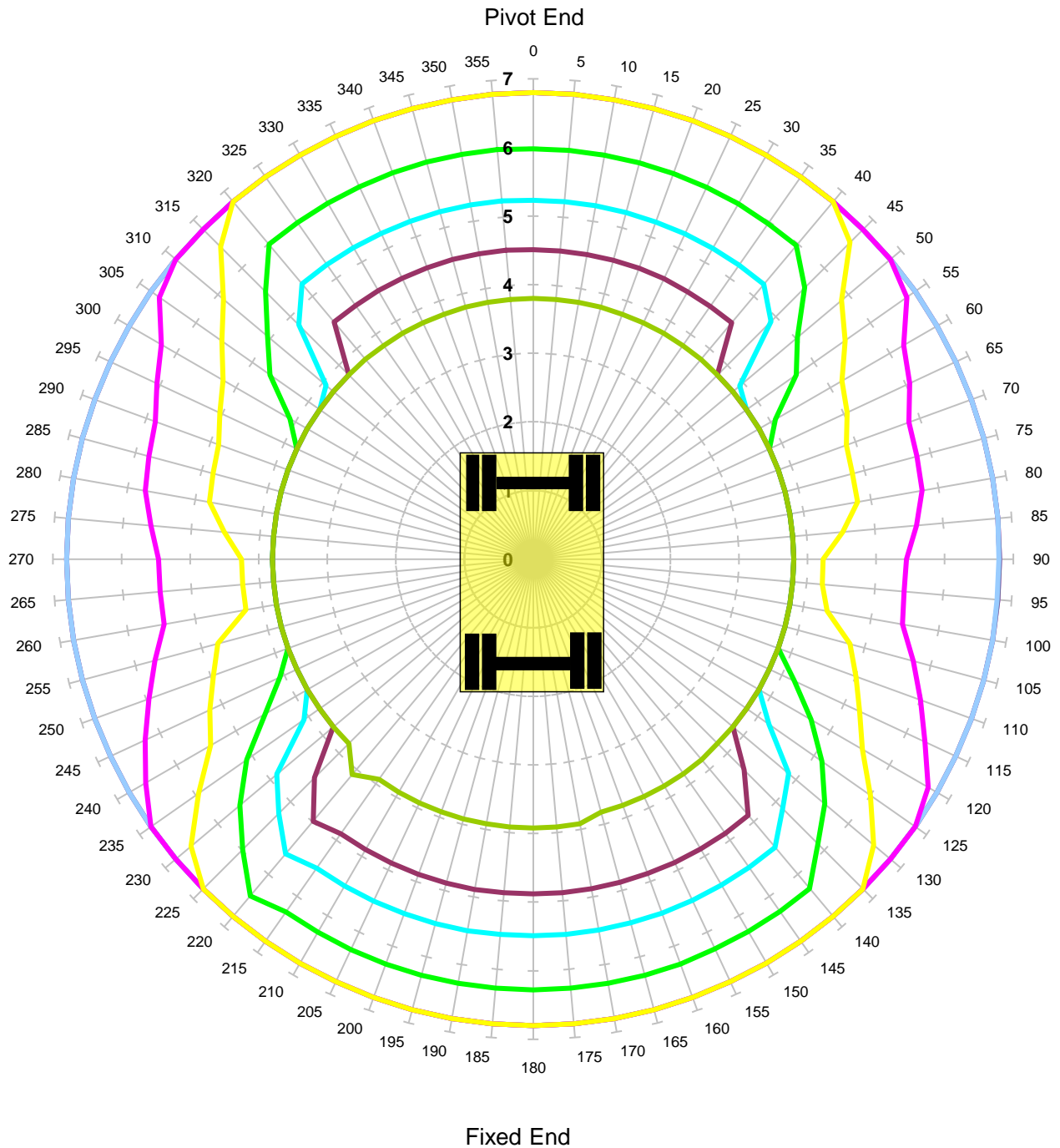

Units in Tonnes

— 1  
 — 2  
 — 3  
 — 4  
 — 5  
 — 6  
 — 7  
 — 8  
 — 9  
 — 10

<b>MACHINE &amp; MODEL:</b>	Colmar T10000FS	<b>REFERENCE:</b>	Dipper Extends by 1000mm
<b>SERIAL No:</b>	8216	<b>DATE OF CHART:</b>	20-May-2019
<b>EQUIPMENT:</b>	4.08m + 2.10m	<b>SAFETY FACTOR:</b>	71.0%
<b>COMMENT:</b>			

## Colmar T10000FS

**Max Capacity Contours of Radius(m) Plots 2.1m Dipper Cwt In  
Gradient 1 in -25 Height 2m Lift BP**

**Unlocked Rail Cant -150mm - Tandem Lift**

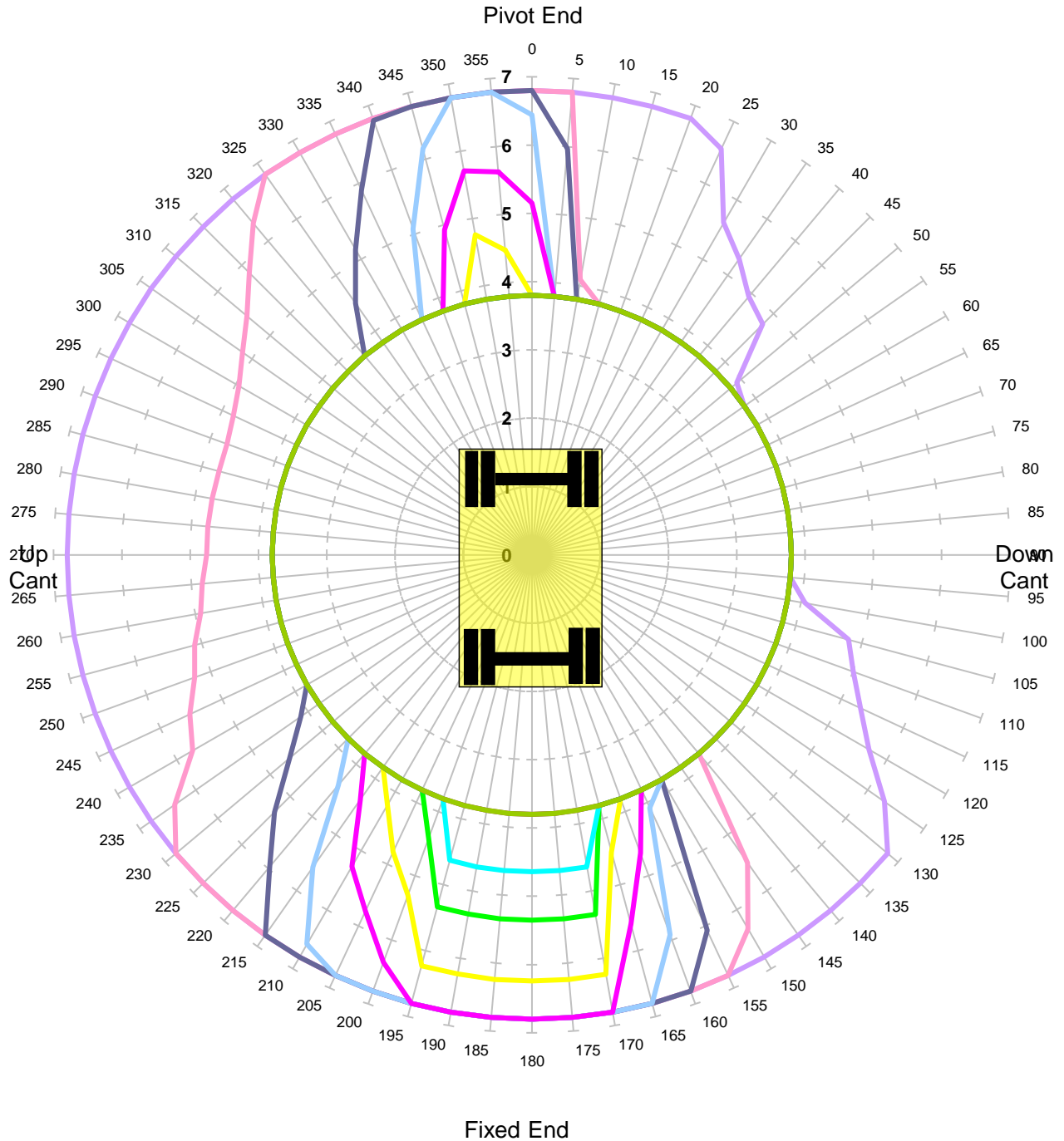

Units in Tonnes

- 1  
 — 2  
 — 3  
 — 4  
 — 5  
 — 6  
 — 7  
 — 8  
 — 9  
 — 10

<b>MACHINE &amp; MODEL:</b>	Colmar T10000FS	<b>REFERENCE:</b>	Dipper Extends by 1000mm
<b>SERIAL No:</b>	8216	<b>DATE OF CHART:</b>	20-May-2019
<b>EQUIPMENT:</b>	4.08m + 2.10m	<b>SAFETY FACTOR:</b>	45.0%
<b>COMMENT:</b>			

## Colmar T10000FS

**Max Capacity Contours of Radius(m) Plots 2.1m Dipper Cwt In  
Gradient 1 in -25 Height 2m Lift BP**

**Unlocked Rail Cant -50mm - Tandem Lift**

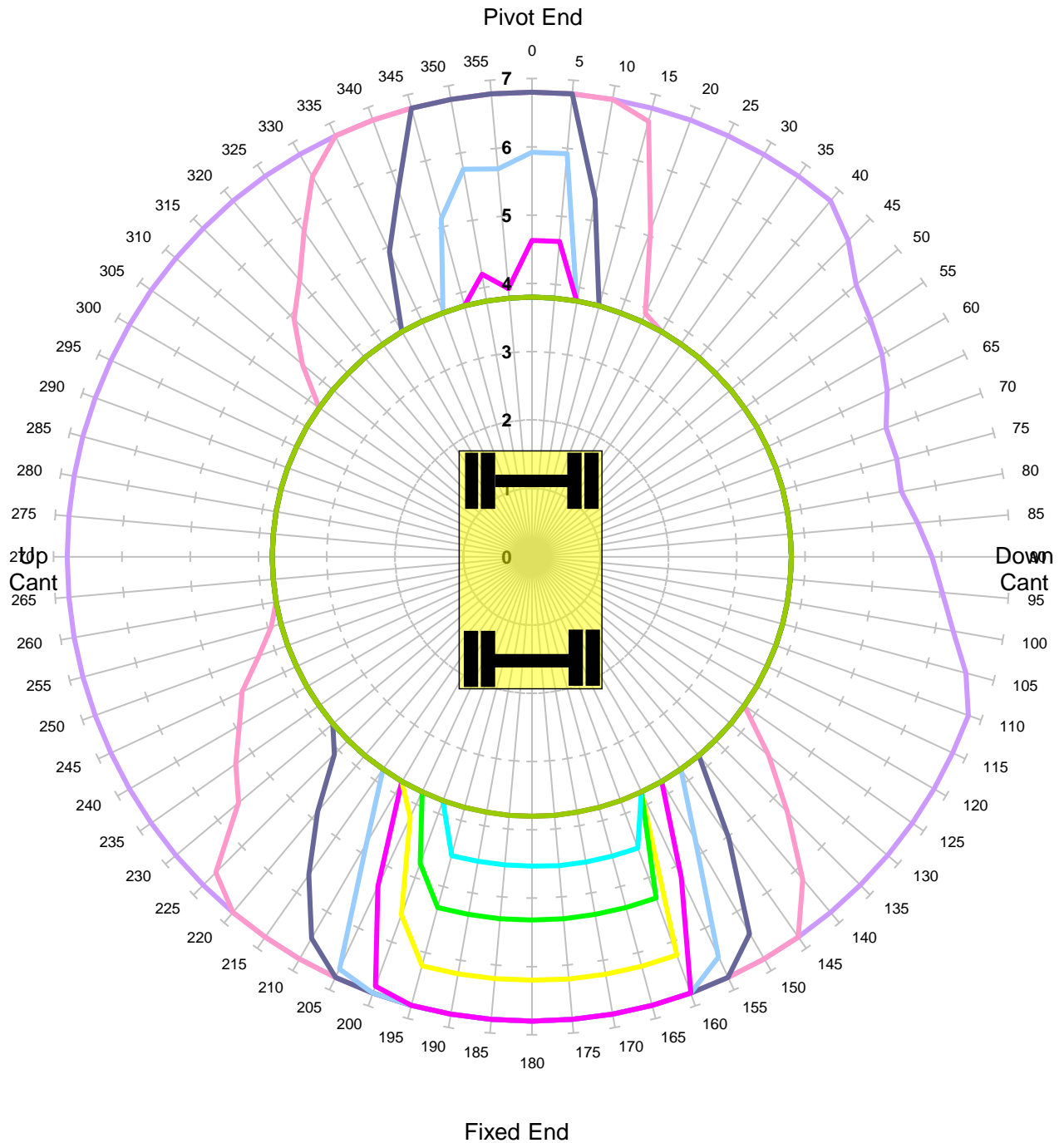

Units in Tonnes

- 1   
 — 2   
 — 3   
 — 4   
 — 5   
 — 6   
 — 7   
 — 8   
 — 9   
 — 10

<b>MACHINE &amp; MODEL:</b>	Colmar T10000FS	<b>REFERENCE:</b>	Dipper Extends by 1000mm
<b>SERIAL No:</b>	8216	<b>DATE OF CHART:</b>	20-May-2019
<b>EQUIPMENT:</b>	4.08m + 2.10m	<b>SAFETY FACTOR:</b>	45.0%
<b>COMMENT:</b>			

## Colmar T10000FS

**Max Capacity Contours of Radius(m) Plots 2.1m Dipper Cwt In  
Gradient 1 in -25 Height 2m Lift BP**

**Unlocked Rail Cant 50mm - Tandem Lift**

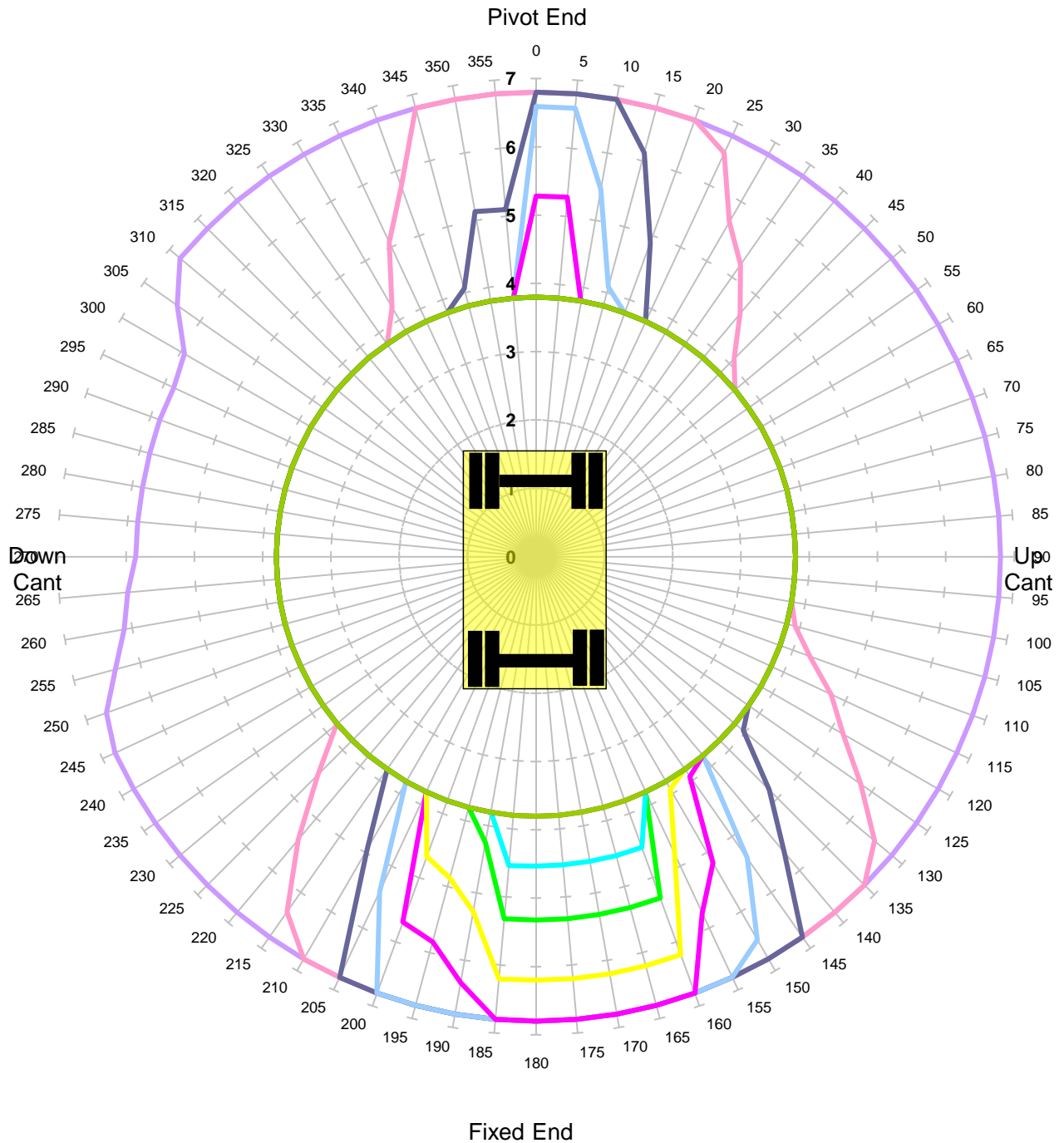

Units in Tonnes

- 1  
 — 2  
 — 3  
 — 4  
 — 5  
 — 6  
 — 7  
 — 8  
 — 9  
 — 10

<b>MACHINE &amp; MODEL:</b>	Colmar T10000FS	<b>REFERENCE:</b>	Dipper Extends by 1000mm
<b>SERIAL No:</b>	8216	<b>DATE OF CHART:</b>	20-May-2019
<b>EQUIPMENT:</b>	4.08m + 2.10m	<b>SAFETY FACTOR:</b>	45.0%
<b>COMMENT:</b>			

## Colmar T10000FS

**Max Capacity Contours of Radius(m) Plots 2.1m Dipper Cwt In  
Gradient 1 in -25 Height 2m Lift BP**

**Unlocked Rail Cant 150mm - Tandem Lift**

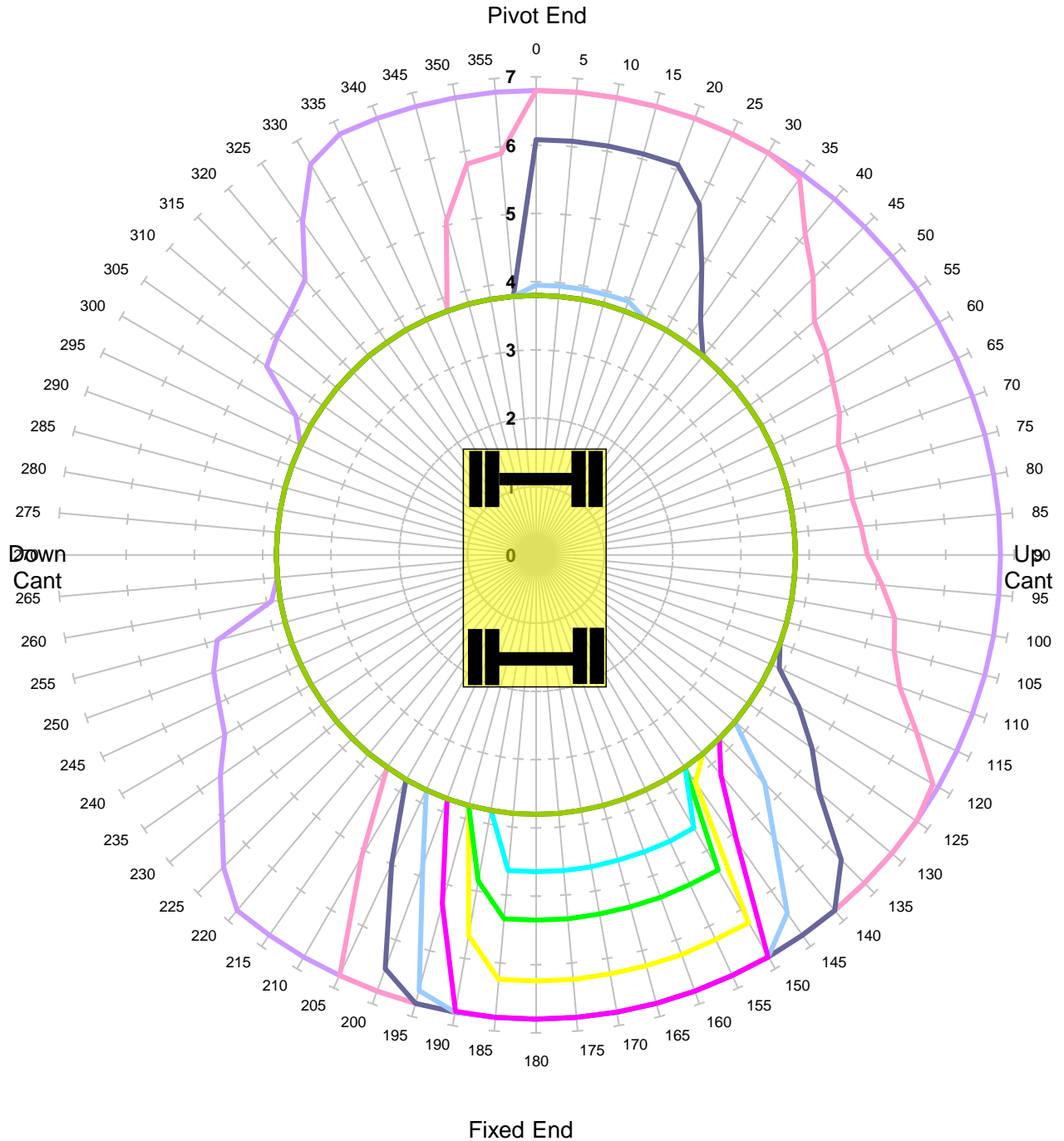

Units in Tonnes

- 1
- 2
- 3
- 4
- 5
- 6
- 7
- 8
- 9
- 10

<b>MACHINE &amp; MODEL:</b>	Colmar T10000FS	<b>REFERENCE:</b>	Dipper Extends by 1000mm
<b>SERIAL No:</b>	8216	<b>DATE OF CHART:</b>	20-May-2019
<b>EQUIPMENT:</b>	4.08m + 2.10m	<b>SAFETY FACTOR:</b>	45.0%
<b>COMMENT:</b>			



## Colmar T10000FS

**Max Capacity Contours of Radius(m) Plots 2.1m Dipper Cwt In  
Gradient 1 in -25 Height 2m Lift BP**

**Locked Rail Cant -150mm - Tandem Lift**

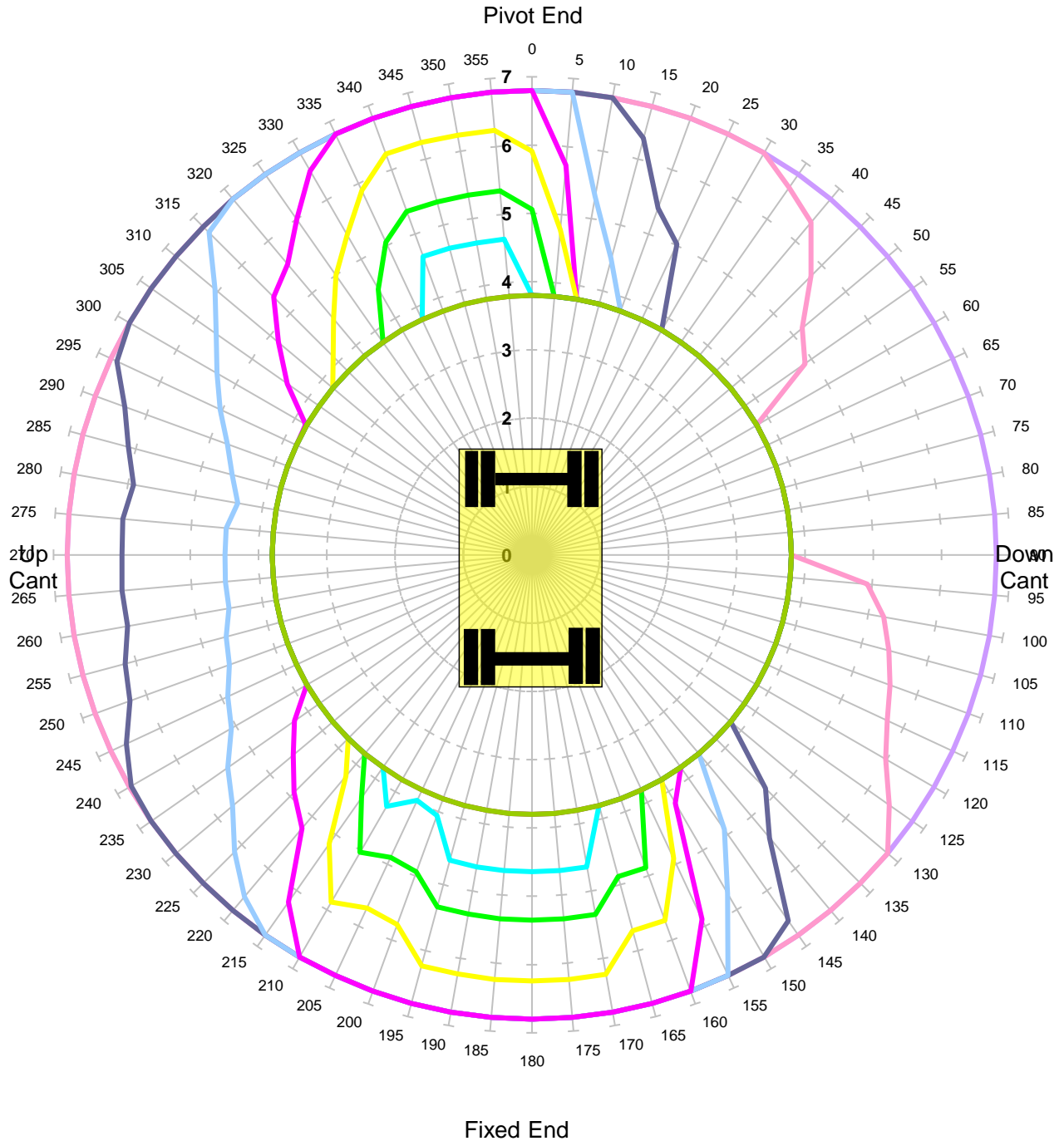

Units in Tonnes

- 1
- 2
- 3
- 4
- 5
- 6
- 7
- 8
- 9
- 10

<b>MACHINE &amp; MODEL:</b>	Colmar T10000FS	<b>REFERENCE:</b>	Dipper Extends by 1000mm
<b>SERIAL No:</b>	8216	<b>DATE OF CHART:</b>	20-May-2019
<b>EQUIPMENT:</b>	4.08m + 2.10m	<b>SAFETY FACTOR:</b>	60.0%
<b>COMMENT:</b>			

## Colmar T10000FS

**Max Capacity Contours of Radius(m) Plots 2.1m Dipper Cwt In  
Gradient 1 in -25 Height 2m Lift BP**

**Locked Rail Cant -50mm - Tandem Lift**

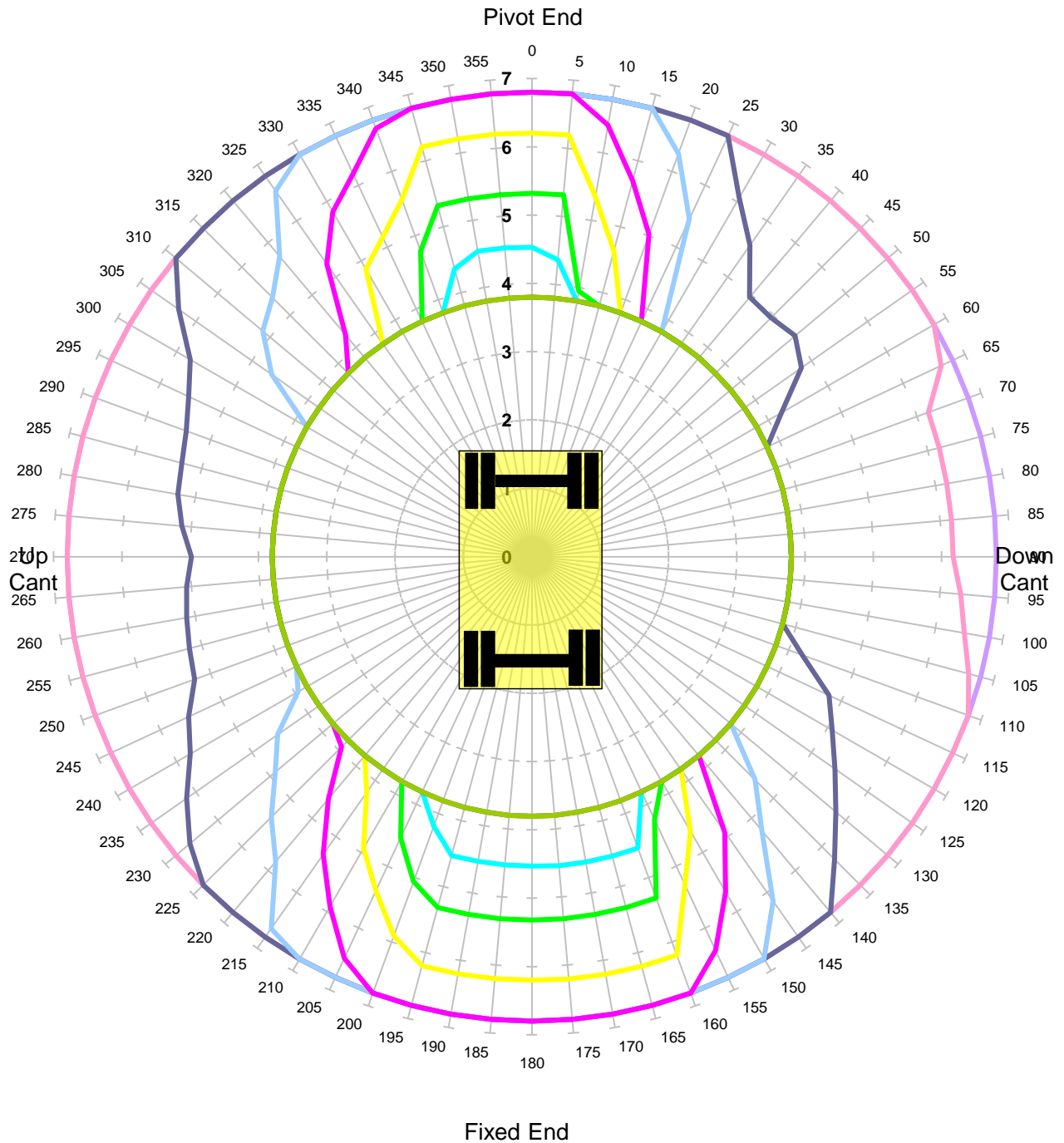

Units in Tonnes

1 2 3 4 5 6 7 8 9 10

<b>MACHINE &amp; MODEL:</b>	Colmar T10000FS	<b>REFERENCE:</b>	Dipper Extends by 1000mm
<b>SERIAL No:</b>	8216	<b>DATE OF CHART:</b>	20-May-2019
<b>EQUIPMENT:</b>	4.08m + 2.10m	<b>SAFETY FACTOR:</b>	60.0%
<b>COMMENT:</b>			

## Colmar T10000FS

**Max Capacity Contours of Radius(m) Plots 2.1m Dipper Cwt In  
Gradient 1 in -25 Height 2m Lift BP**

**Locked Rail Cant 50mm - Tandem Lift**

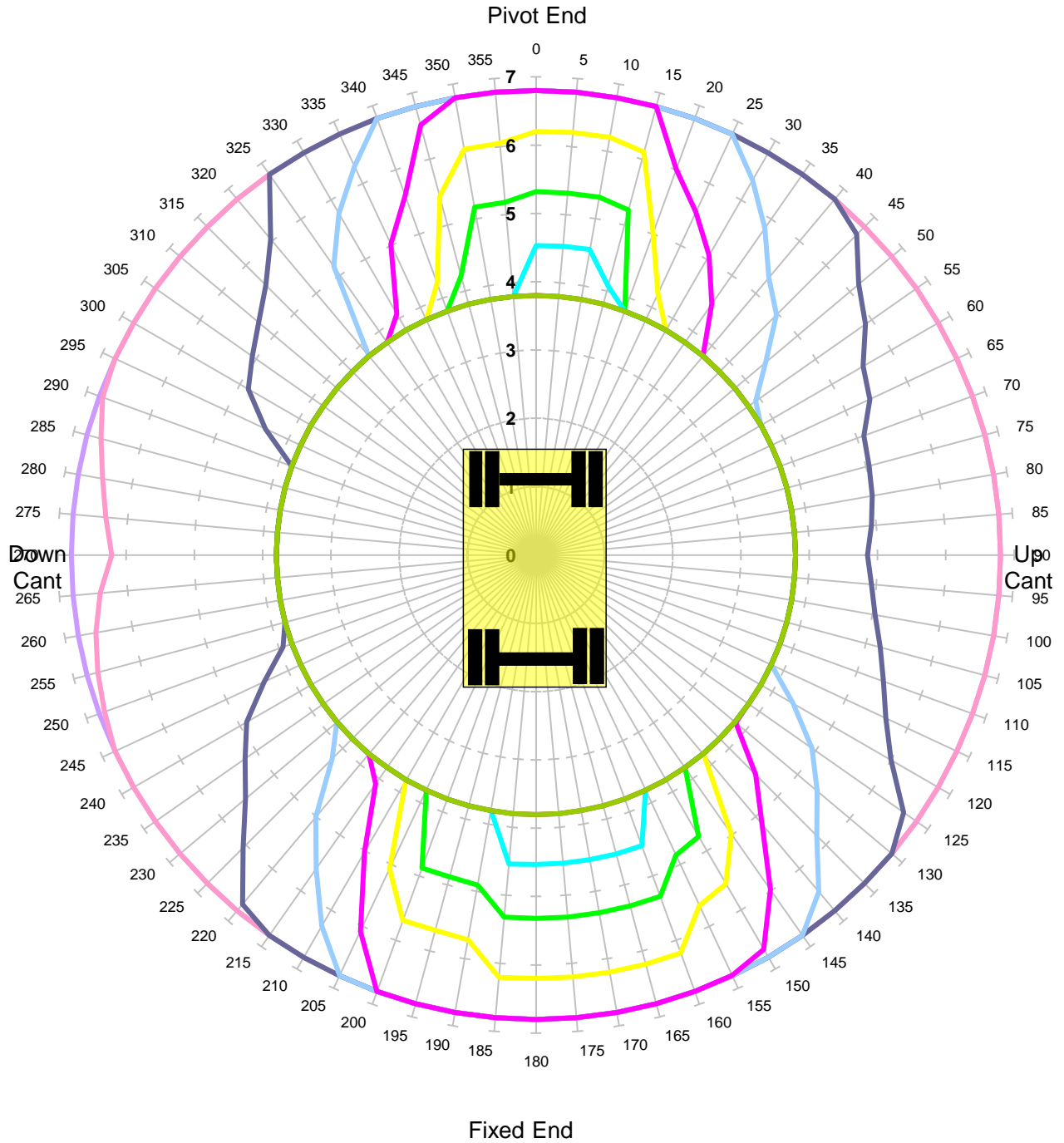

Units in Tonnes

- 1  
 — 2  
 — 3  
 — 4  
 — 5  
 — 6  
 — 7  
 — 8  
 — 9  
 — 10

<b>MACHINE &amp; MODEL:</b>	Colmar T10000FS	<b>REFERENCE:</b>	Dipper Extends by 1000mm
<b>SERIAL No:</b>	8216	<b>DATE OF CHART:</b>	20-May-2019
<b>EQUIPMENT:</b>	4.08m + 2.10m	<b>SAFETY FACTOR:</b>	60.0%
<b>COMMENT:</b>			

# Colmar T10000FS

**Max Capacity Contours of Radius(m) Plots 2.1m Dipper Cwt In  
Gradient 1 in -25 Height 2m Lift BP**

**Locked Rail Cant 150mm - Tandem Lift**

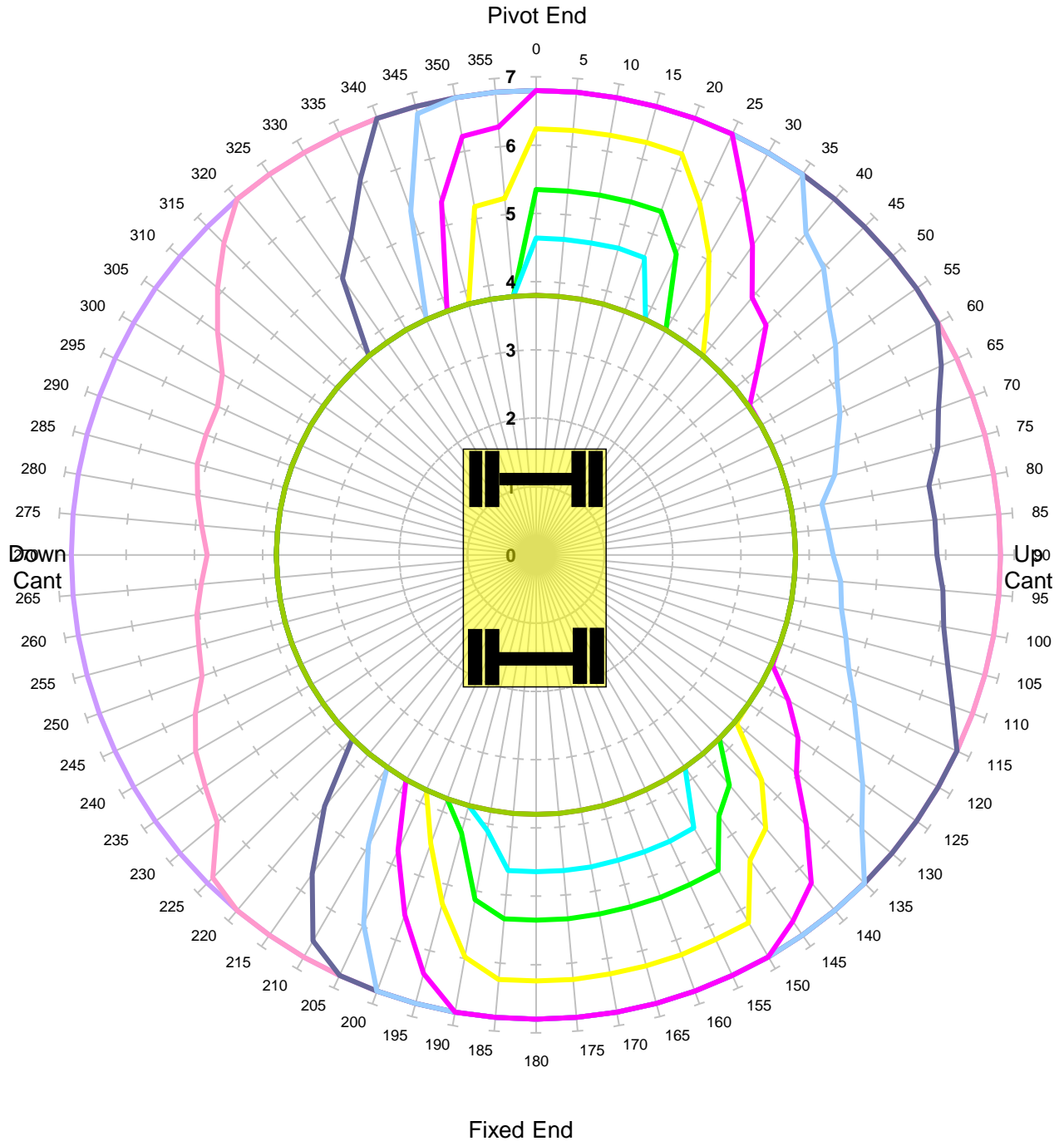

Units in Tonnes

- 1
- 2
- 3
- 4
- 5
- 6
- 7
- 8
- 9
- 10

<b>MACHINE &amp; MODEL:</b>	Colmar T10000FS	<b>REFERENCE:</b>	Dipper Extends by 1000mm
<b>SERIAL No:</b>	8216	<b>DATE OF CHART:</b>	20-May-2019
<b>EQUIPMENT:</b>	4.08m + 2.10m	<b>SAFETY FACTOR:</b>	60.0%
<b>COMMENT:</b>			

## Colmar T10000FS

**Max Capacity Contours of Radius(m) Plots 2.1m Dipper Cwt In  
Level Ground Height 2m Lift BP**

**Unlocked Road - Tandem Lift**

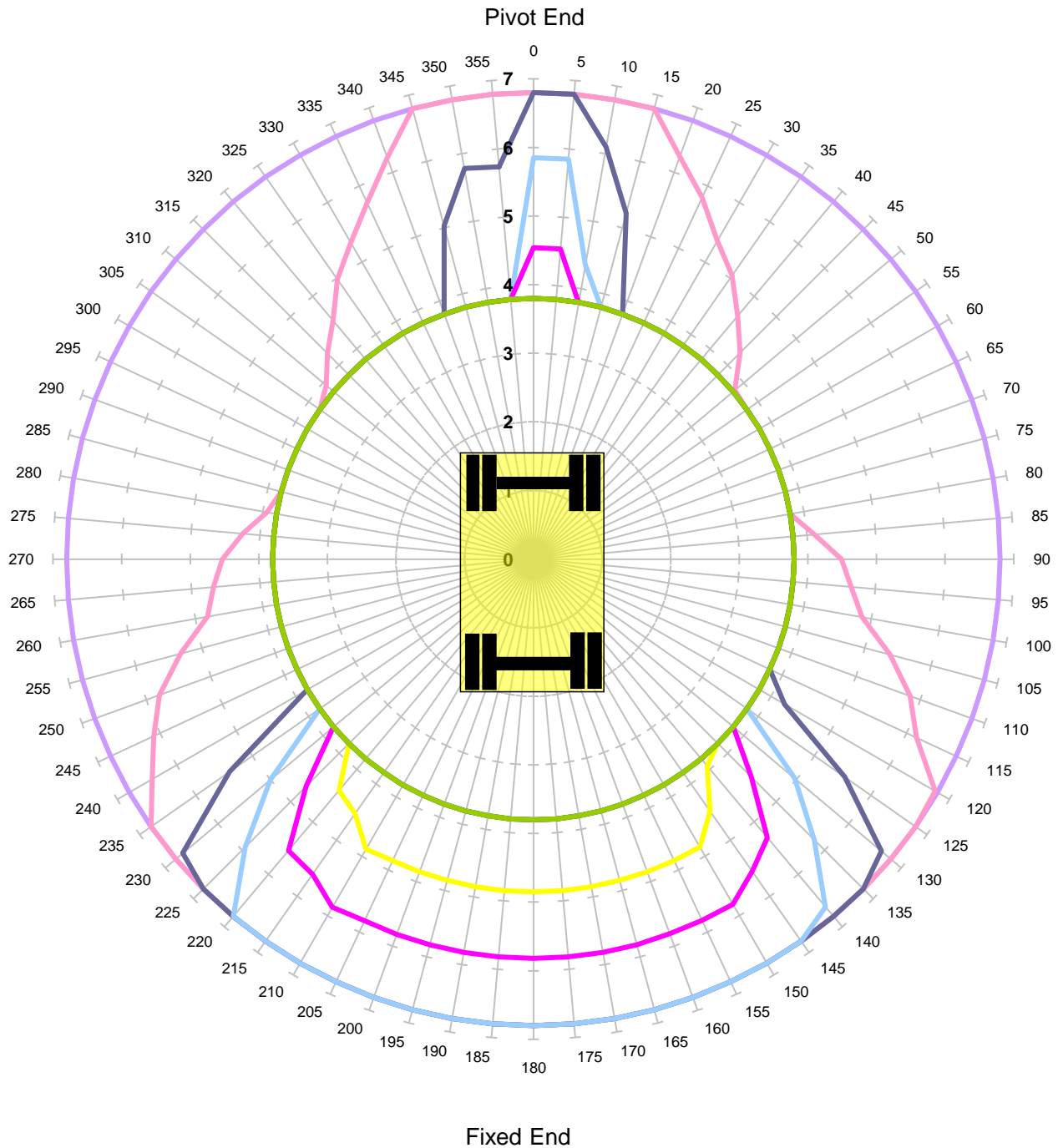

Units in Tonnes

— 1   
 — 2   
 — 3   
 — 4   
 — 5   
 — 6   
 — 7   
 — 8   
 — 9   
 — 10

<b>MACHINE &amp; MODEL:</b>	Colmar T10000FS	<b>REFERENCE:</b>	Dipper Extends by 1000mm
<b>SERIAL No:</b>	8216	<b>DATE OF CHART:</b>	20-May-2019
<b>EQUIPMENT:</b>	4.08m + 2.10m	<b>SAFETY FACTOR:</b>	47.0%
<b>COMMENT:</b>			

## Colmar T10000FS

**Max Capacity Contours of Radius(m) Plots 2.1m Dipper Cwt In  
Level Ground Height 2m Lift BP**

**Locked Road - Tandem Lift**

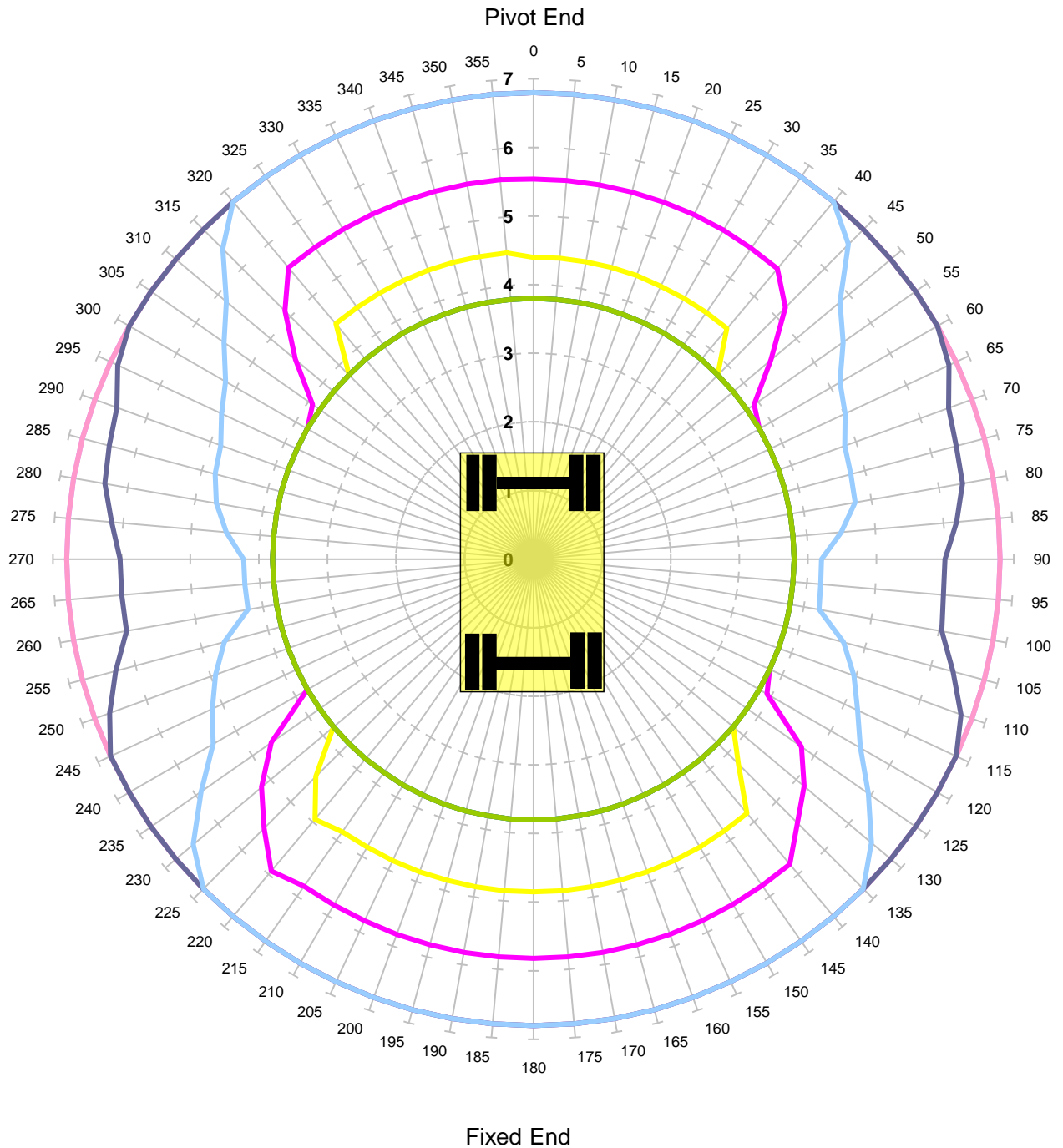

Units in Tonnes

— 1  
 — 2  
 — 3  
 — 4  
 — 5  
 — 6  
 — 7  
 — 8  
 — 9  
 — 10

<b>MACHINE &amp; MODEL:</b>	Colmar T10000FS	<b>REFERENCE:</b>	Dipper Extends by 1000mm
<b>SERIAL No:</b>	8216	<b>DATE OF CHART:</b>	20-May-2019
<b>EQUIPMENT:</b>	4.08m + 2.10m	<b>SAFETY FACTOR:</b>	47.0%
<b>COMMENT:</b>			



**Colmar T10000FS**  
**Max Capacity Contours of Radius(m) Plots 3.1m Dipper Cwt In**  
**Gradient 1 in -25 Height 2m Lift BP**  
**Unlocked Rail Cant -150mm**

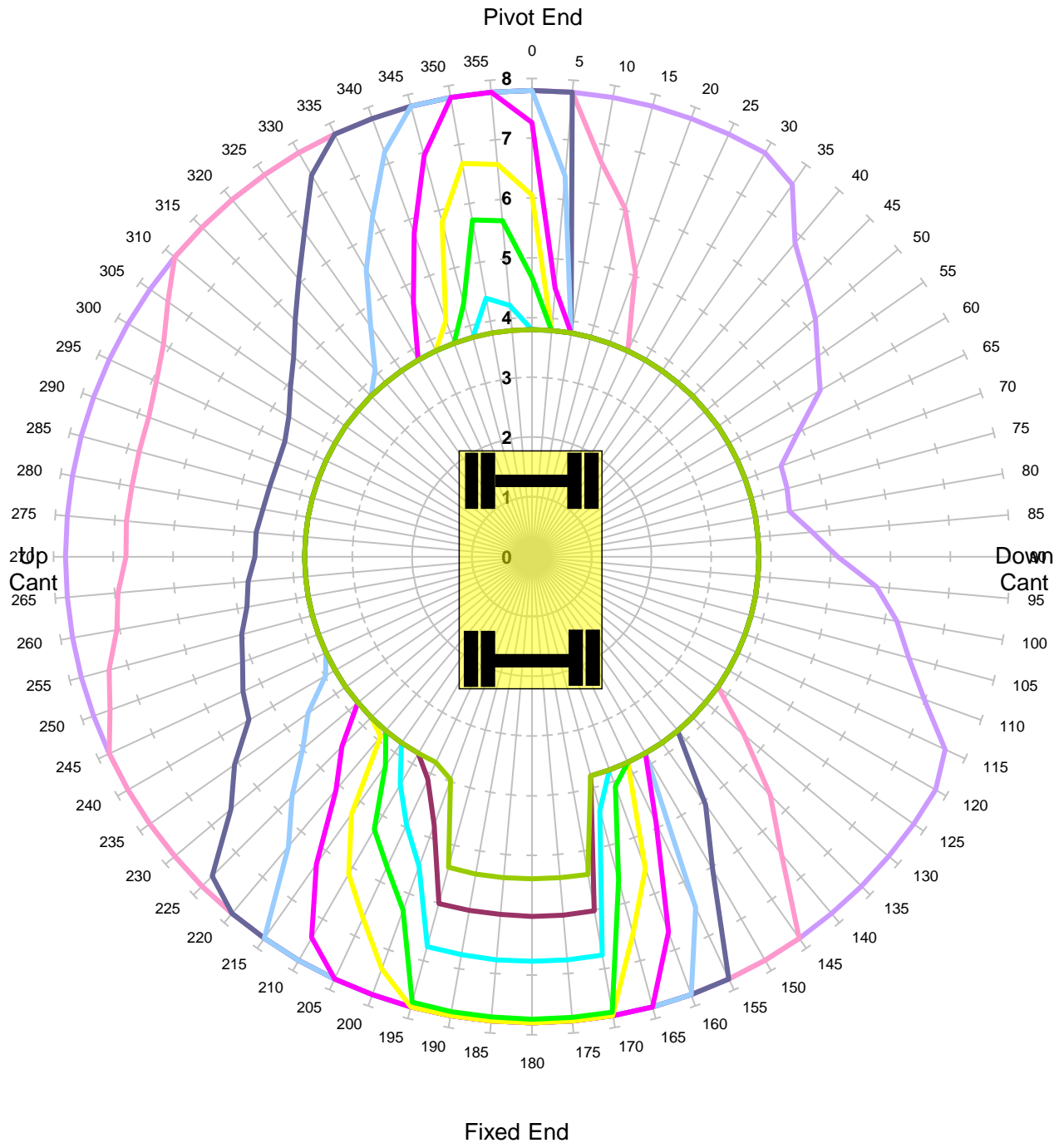

Units in Tonnes  
 1 2 3 4 5 6 7 8 9 10

<b>MACHINE &amp; MODEL:</b>	Colmar T10000FS	<b>REFERENCE:</b>	Dipper Extends by 1000mm
<b>SERIAL No:</b>	8216	<b>DATE OF CHART:</b>	20-May-2019
<b>EQUIPMENT:</b>	4.08m + 2.10m	<b>SAFETY FACTOR:</b>	67.0%
<b>COMMENT:</b>			

## Colmar T10000FS

**Max Capacity Contours of Radius(m) Plots 3.1m Dipper Cwt In  
Gradient 1 in -25 Height 2m Lift BP**

**Unlocked Rail Cant -50mm**

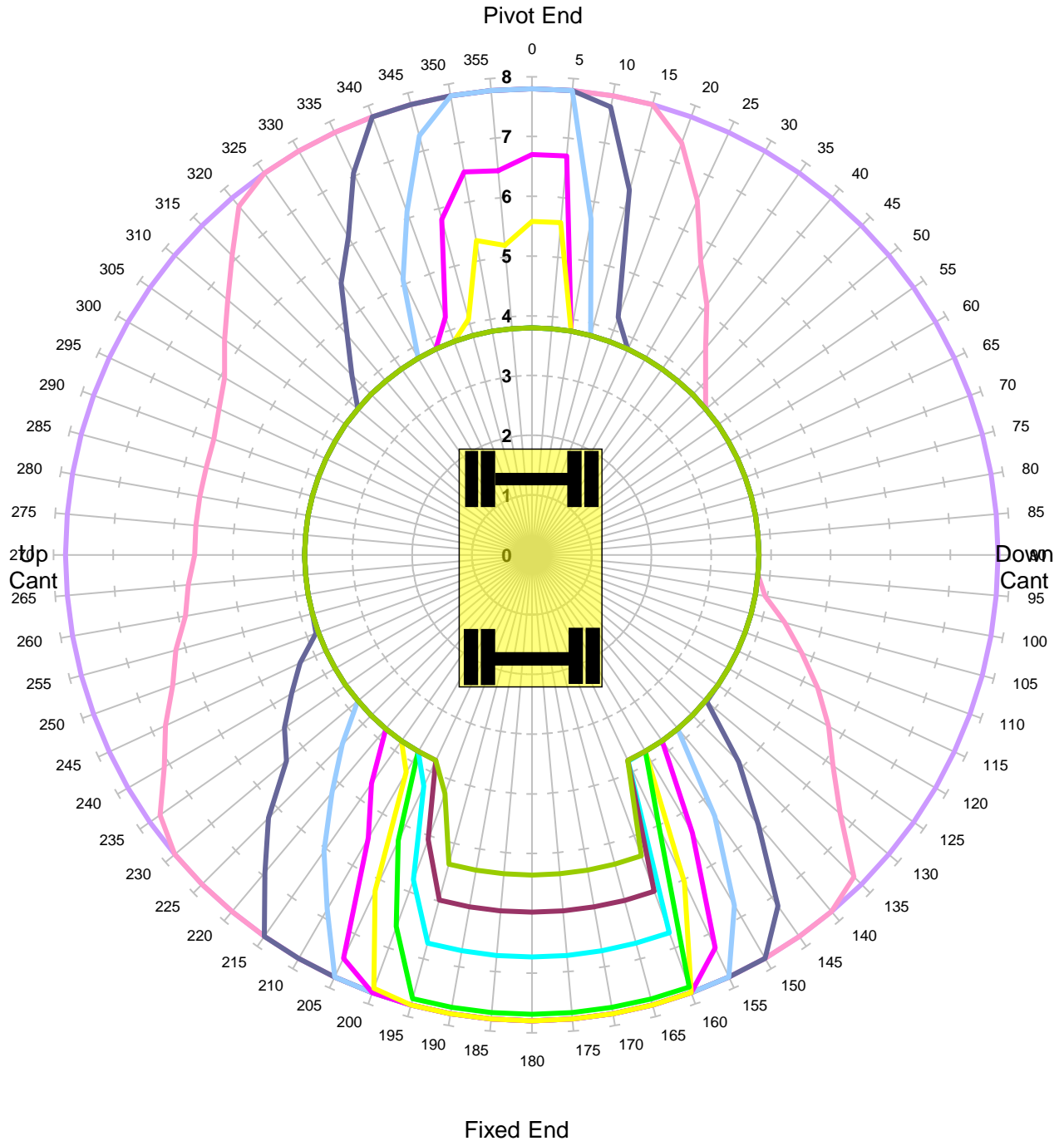

Units in Tonnes

- 1   
 — 2   
 — 3   
 — 4   
 — 5   
 — 6   
 — 7   
 — 8   
 — 9   
 — 10

<b>MACHINE &amp; MODEL:</b>	Colmar T10000FS	<b>REFERENCE:</b>	Dipper Extends by 1000mm
<b>SERIAL No:</b>	8216	<b>DATE OF CHART:</b>	20-May-2019
<b>EQUIPMENT:</b>	4.08m + 2.10m	<b>SAFETY FACTOR:</b>	67.0%
<b>COMMENT:</b>			

**Colmar T10000FS**  
**Max Capacity Contours of Radius(m) Plots 3.1m Dipper Cwt In**  
**Gradient 1 in -25 Height 2m Lift BP**  
**Unlocked Rail Cant 50mm**

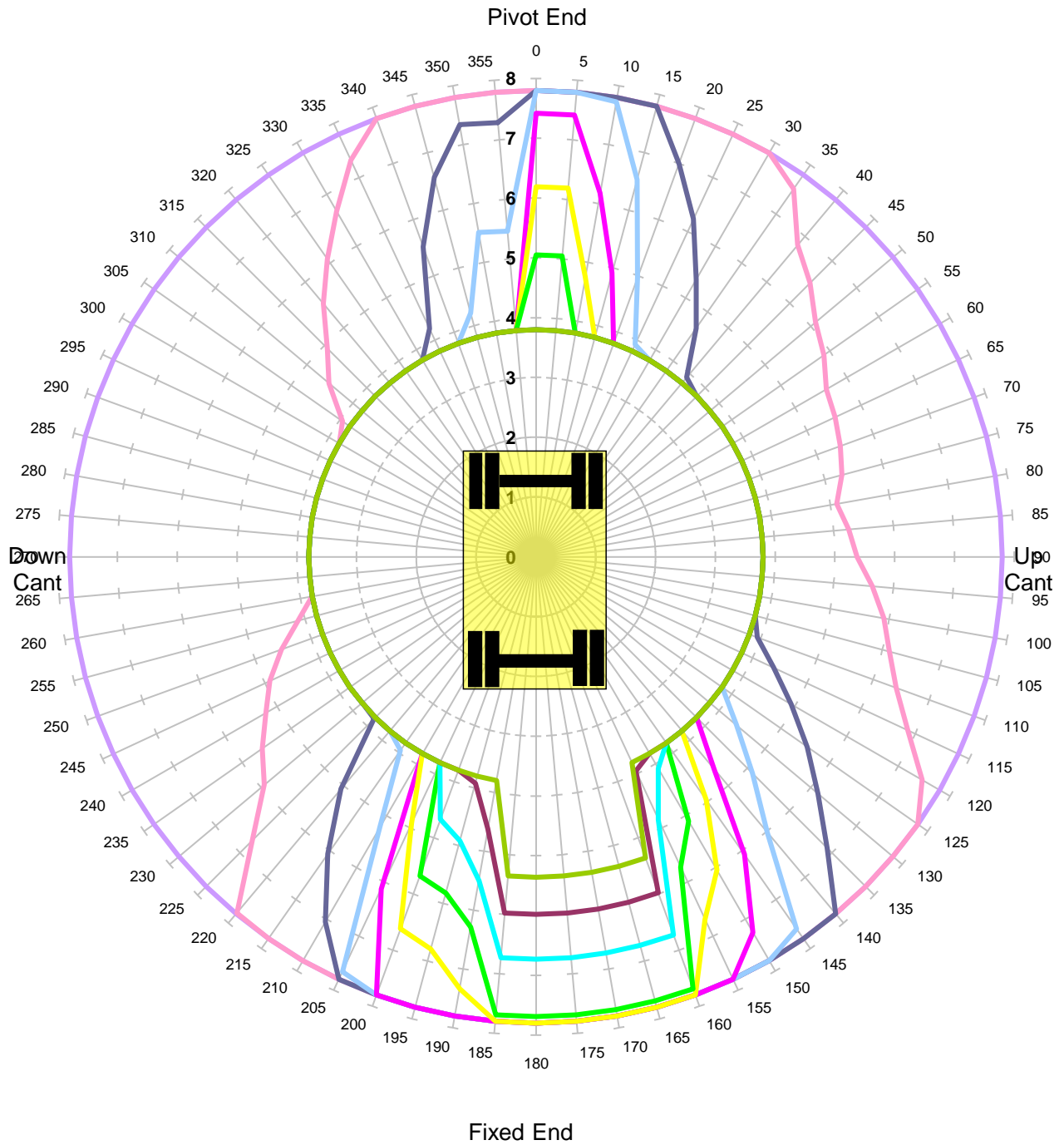

Units in Tonnes  
 1 2 3 4 5 6 7 8 9 10

<b>MACHINE &amp; MODEL:</b>	Colmar T10000FS	<b>REFERENCE:</b>	Dipper Extends by 1000mm
<b>SERIAL No:</b>	8216	<b>DATE OF CHART:</b>	20-May-2019
<b>EQUIPMENT:</b>	4.08m + 2.10m	<b>SAFETY FACTOR:</b>	67.0%
<b>COMMENT:</b>			

**Colmar T10000FS**  
**Max Capacity Contours of Radius(m) Plots 3.1m Dipper Cwt In**  
**Gradient 1 in -25 Height 2m Lift BP**  
**Unlocked Rail Cant 150mm**

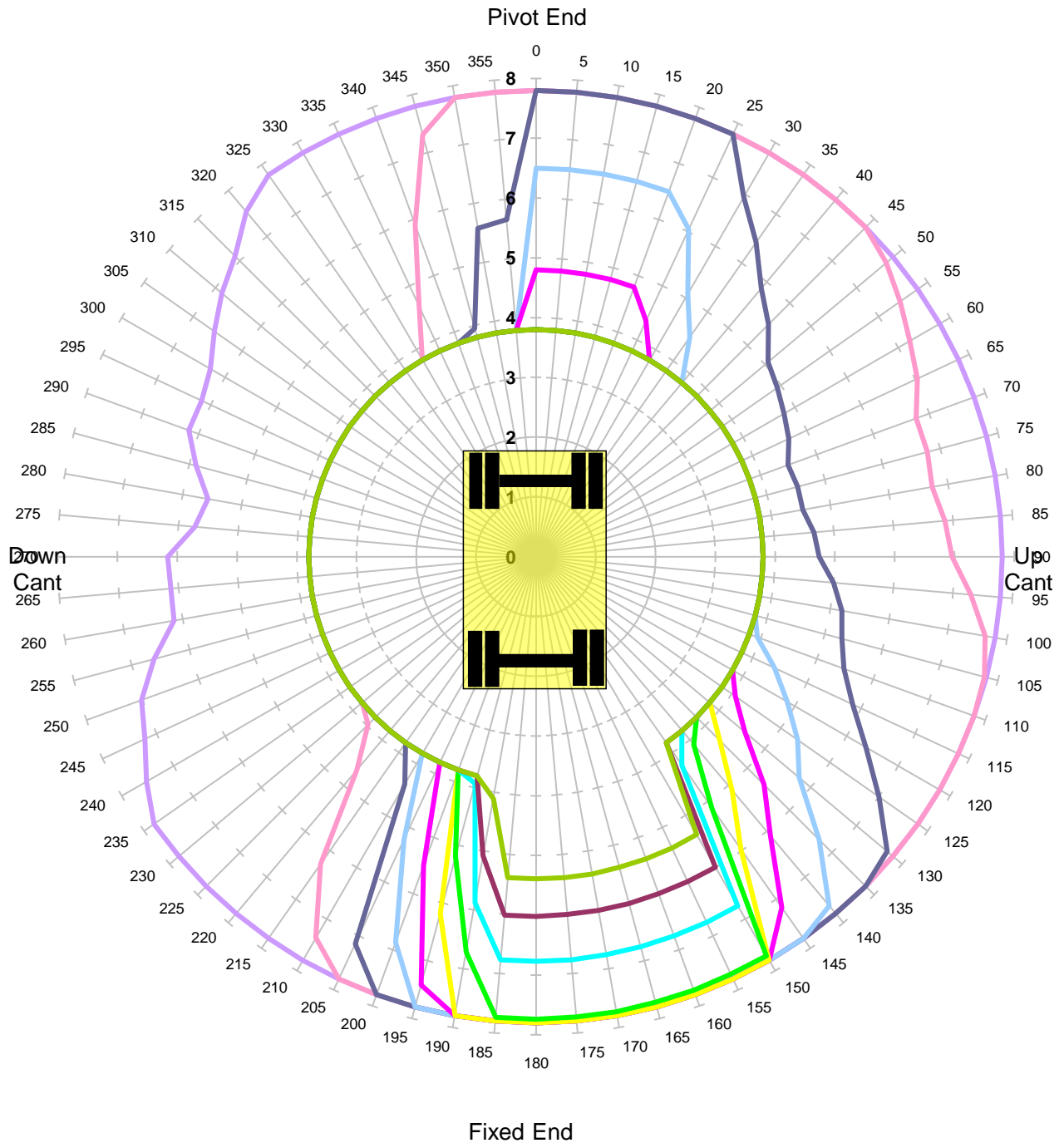

Units in Tonnes

- 1
- 2
- 3
- 4
- 5
- 6
- 7
- 8
- 9
- 10

<b>MACHINE &amp; MODEL:</b>	Colmar T10000FS	<b>REFERENCE:</b>	Dipper Extends by 1000mm
<b>SERIAL No:</b>	8216	<b>DATE OF CHART:</b>	20-May-2019
<b>EQUIPMENT:</b>	4.08m + 2.10m	<b>SAFETY FACTOR:</b>	67.0%
<b>COMMENT:</b>			

**Colmar T10000FS**  
**Max Capacity Contours of Radius(m) Plots 3.1m Dipper Cwt In**  
**Gradient 1 in -25 Height 2m Lift BP**  
**Locked Rail Cant -150mm**

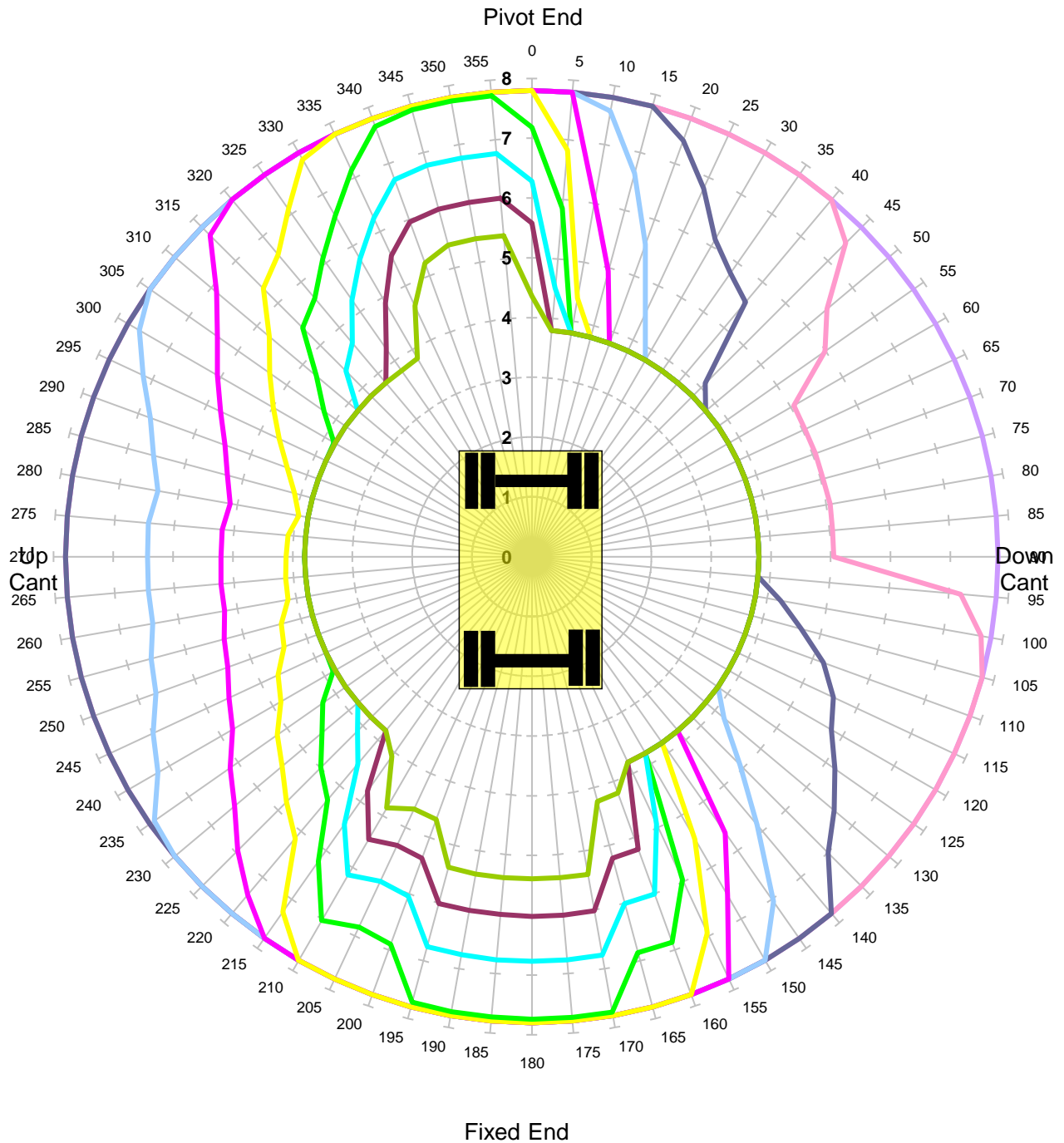

Units in Tonnes  
 1 2 3 4 5 6 7 8 9 10

<b>MACHINE &amp; MODEL:</b>	Colmar T10000FS	<b>REFERENCE:</b>	Dipper Extends by 1000mm
<b>SERIAL No:</b>	8216	<b>DATE OF CHART:</b>	20-May-2019
<b>EQUIPMENT:</b>	4.08m + 2.10m	<b>SAFETY FACTOR:</b>	90.0%
<b>COMMENT:</b>			

**Colmar T10000FS**  
**Max Capacity Contours of Radius(m) Plots 3.1m Dipper Cwt In**  
**Gradient 1 in -25 Height 2m Lift BP**  
**Locked Rail Cant -50mm**

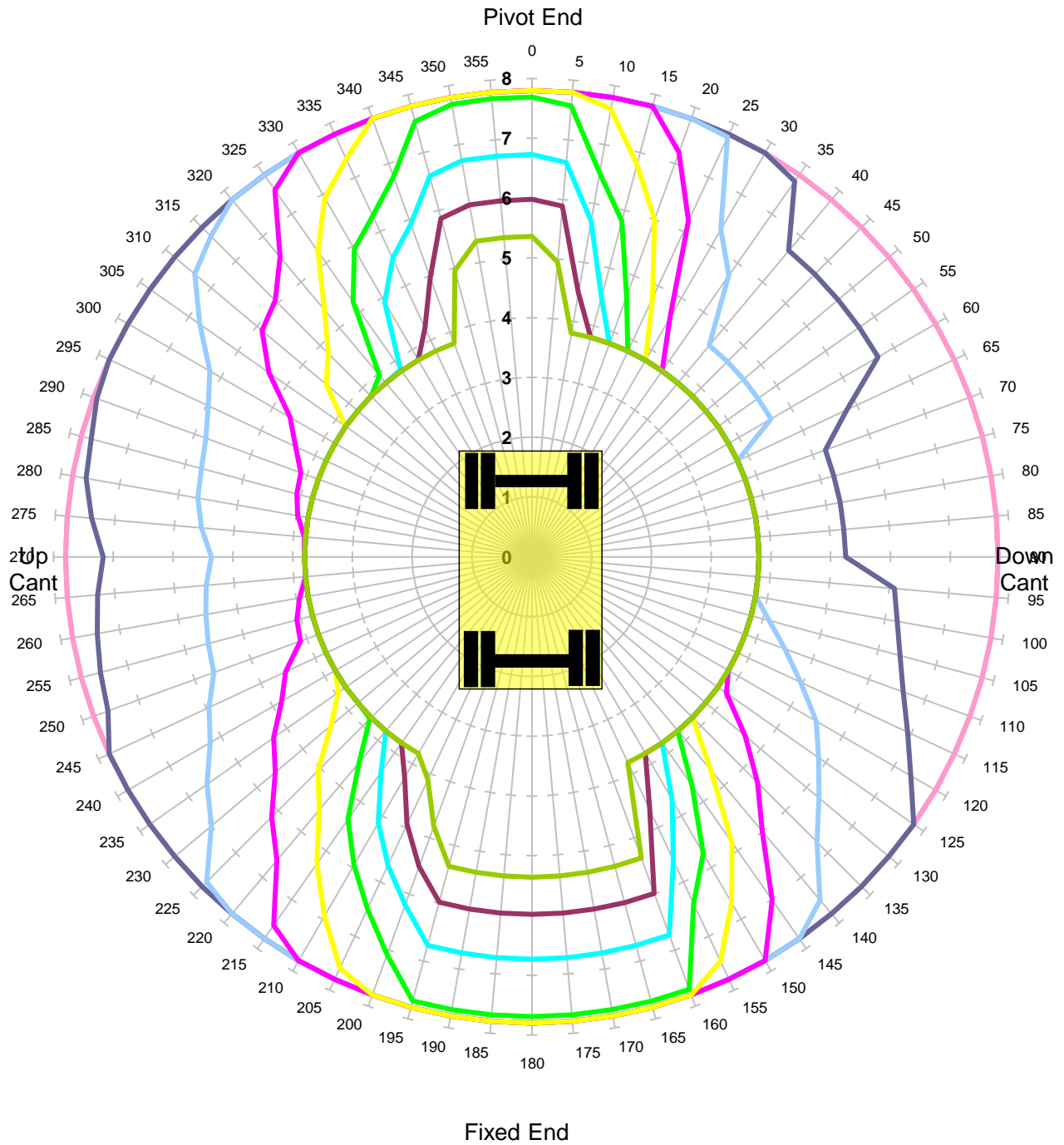

Units in Tonnes  
 1 2 3 4 5 6 7 8 9 10

<b>MACHINE &amp; MODEL:</b>	Colmar T10000FS	<b>REFERENCE:</b>	Dipper Extends by 1000mm
<b>SERIAL No:</b>	8216	<b>DATE OF CHART:</b>	20-May-2019
<b>EQUIPMENT:</b>	4.08m + 2.10m	<b>SAFETY FACTOR:</b>	90.0%
<b>COMMENT:</b>			



**Colmar T10000FS**  
**Max Capacity Contours of Radius(m) Plots 3.1m Dipper Cwt In**  
**Gradient 1 in -25 Height 2m Lift BP**  
**Locked Rail Cant 50mm**

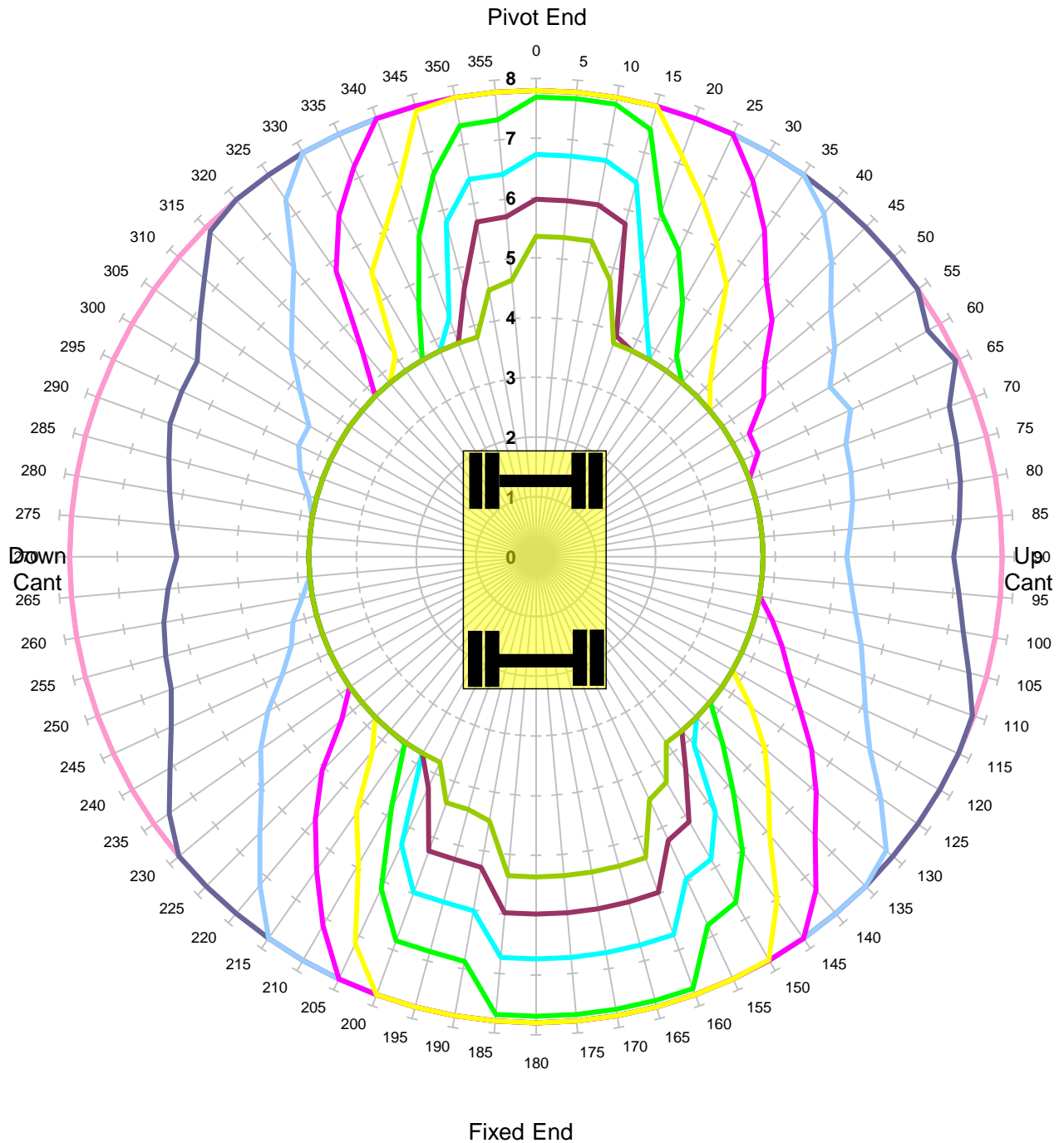

Units in Tonnes

- 1 2 3 4 5 6 7 8 9 10

<b>MACHINE &amp; MODEL:</b>	Colmar T10000FS	<b>REFERENCE:</b>	Dipper Extends by 1000mm
<b>SERIAL No:</b>	8216	<b>DATE OF CHART:</b>	20-May-2019
<b>EQUIPMENT:</b>	4.08m + 2.10m	<b>SAFETY FACTOR:</b>	90.0%
<b>COMMENT:</b>			

**Colmar T10000FS**  
**Max Capacity Contours of Radius(m) Plots 3.1m Dipper Cwt In**  
**Gradient 1 in -25 Height 2m Lift BP**  
**Locked Rail Cant 150mm**

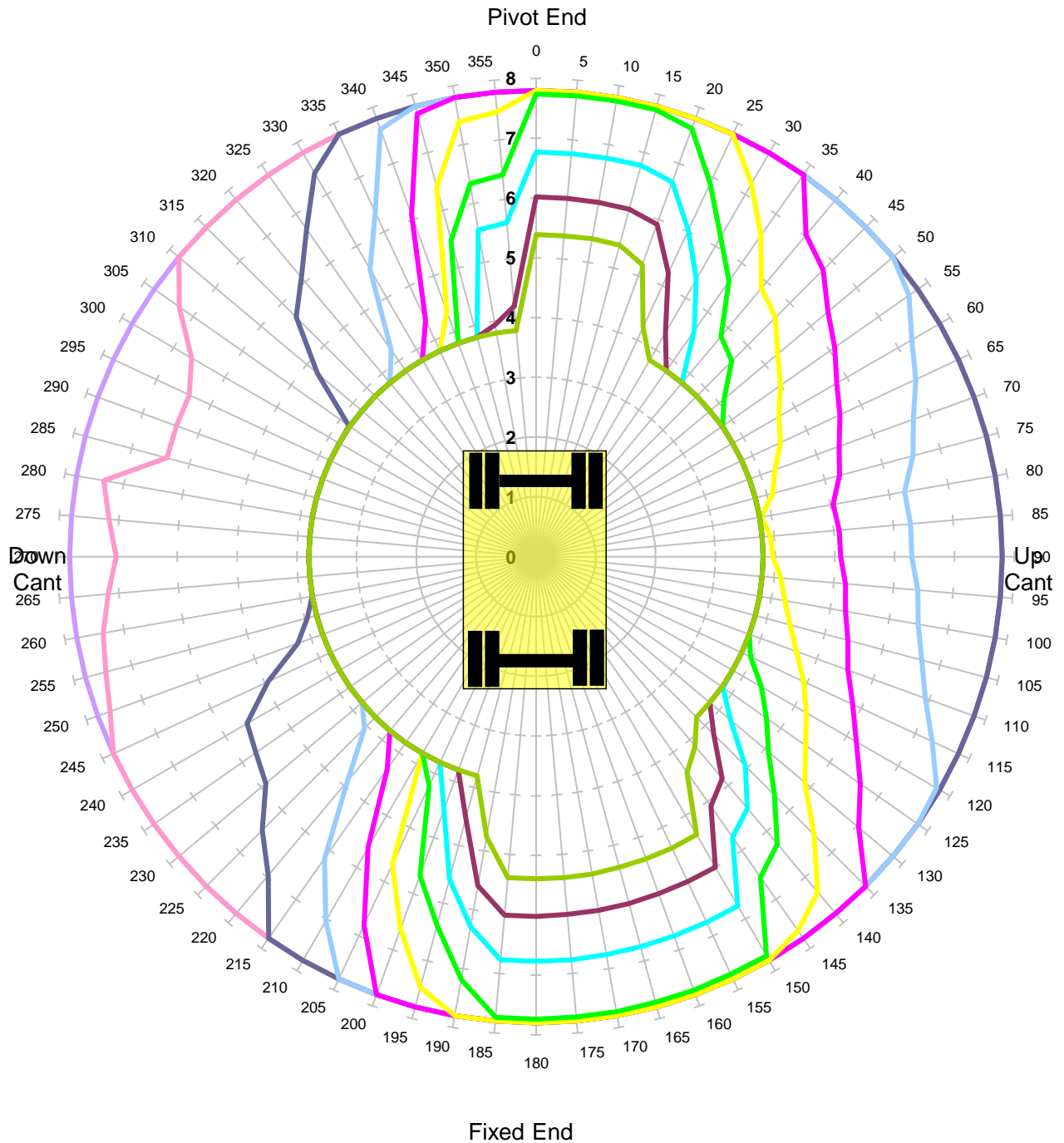

Units in Tonnes

- 1   
 — 2   
 — 3   
 — 4   
 — 5   
 — 6   
 — 7   
 — 8   
 — 9   
 — 10

<b>MACHINE &amp; MODEL:</b>	Colmar T10000FS	<b>REFERENCE:</b>	Dipper Extends by 1000mm
<b>SERIAL No:</b>	8216	<b>DATE OF CHART:</b>	20-May-2019
<b>EQUIPMENT:</b>	4.08m + 2.10m	<b>SAFETY FACTOR:</b>	90.0%
<b>COMMENT:</b>			

## Colmar T10000FS

**Max Capacity Contours of Radius(m) Plots 3.1m Dipper Cwt In  
Level Ground Height 2m Lift BP  
Unlocked Road**

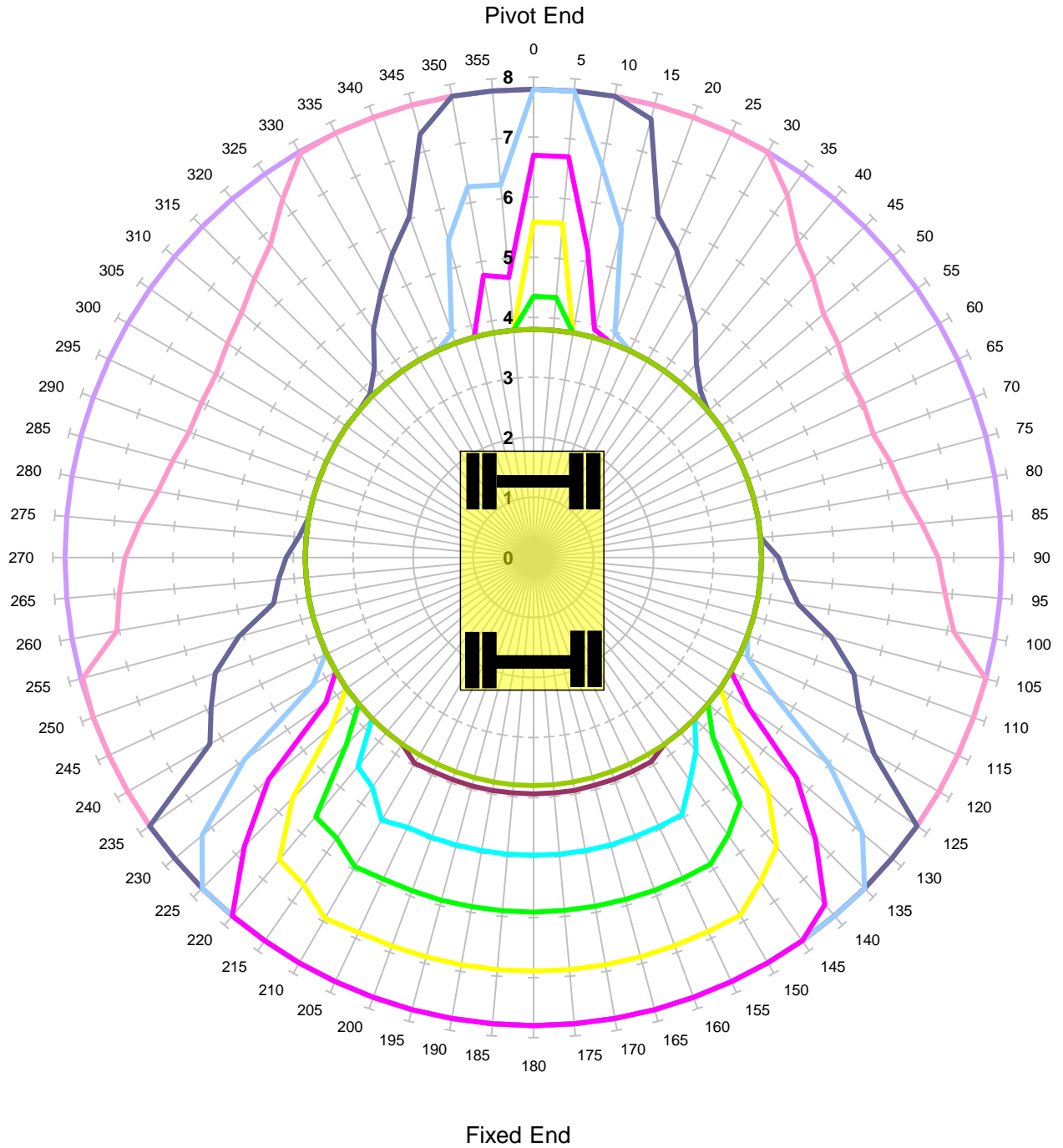

Units in Tonnes

- 1
- 2
- 3
- 4
- 5
- 6
- 7
- 8
- 9
- 10

<b>MACHINE &amp; MODEL:</b>	Colmar T10000FS	<b>REFERENCE:</b>	Dipper Extends by 1000mm
<b>SERIAL No:</b>	8216	<b>DATE OF CHART:</b>	20-May-2019
<b>EQUIPMENT:</b>	4.08m + 2.10m	<b>SAFETY FACTOR:</b>	71.0%
<b>COMMENT:</b>			

# Colmar T10000FS

**Max Capacity Contours of Radius(m) Plots 3.1m Dipper Cwt In  
Level Ground Height 2m Lift BP  
Locked Road**

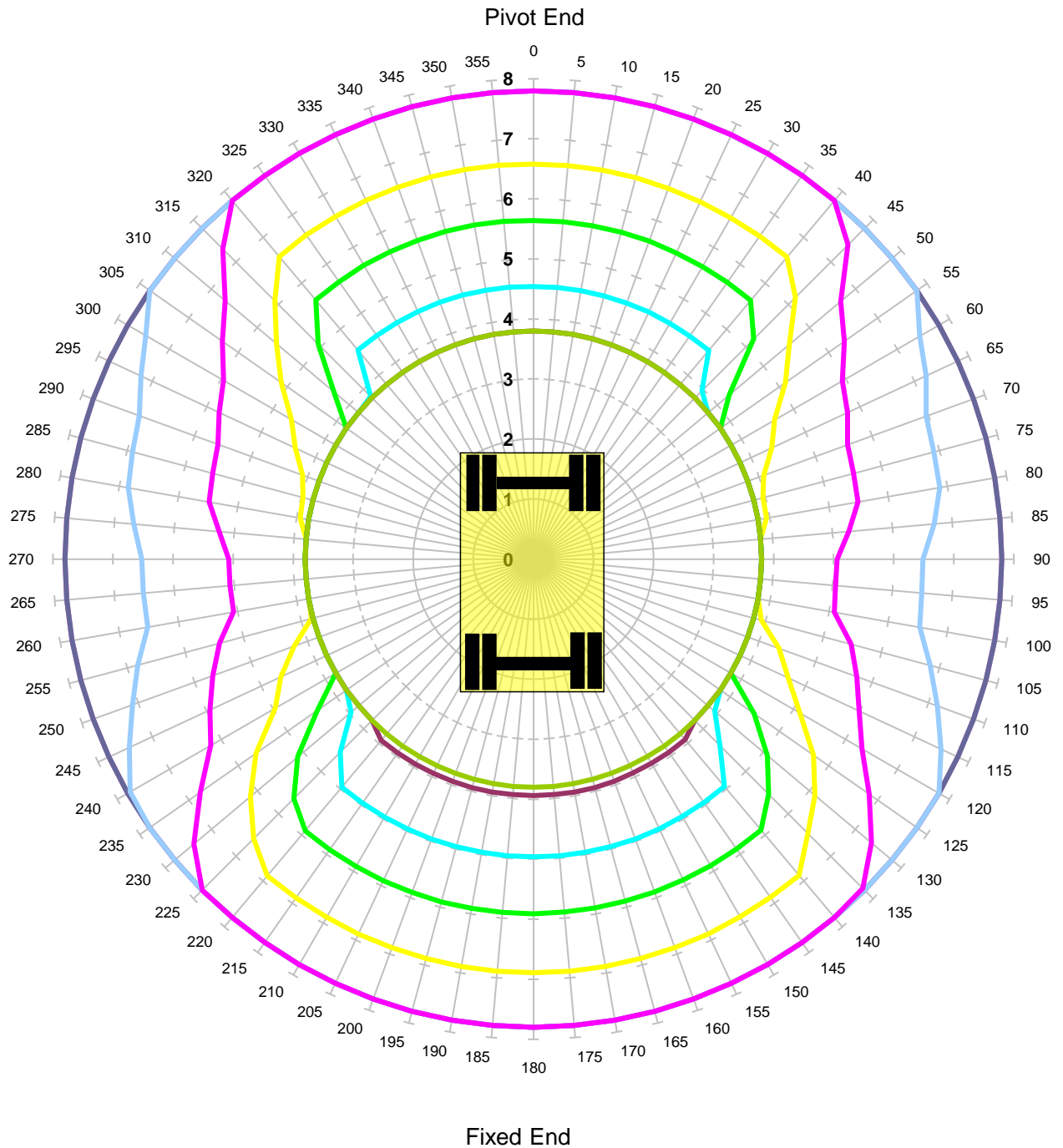

Units in Tonnes

- 1
- 2
- 3
- 4
- 5
- 6
- 7
- 8
- 9
- 10

<b>MACHINE &amp; MODEL:</b>	Colmar T10000FS	<b>REFERENCE:</b>	Dipper Extends by 1000mm
<b>SERIAL No:</b>	8216	<b>DATE OF CHART:</b>	20-May-2019
<b>EQUIPMENT:</b>	4.08m + 2.10m	<b>SAFETY FACTOR:</b>	71.0%
<b>COMMENT:</b>			

## Colmar T10000FS

**Max Capacity Contours of Radius(m) Plots 3.1m Dipper Cwt In  
Gradient 1 in -25 Height 2m Lift BP**

**Unlocked Rail Cant -150mm - Tandem Lift**

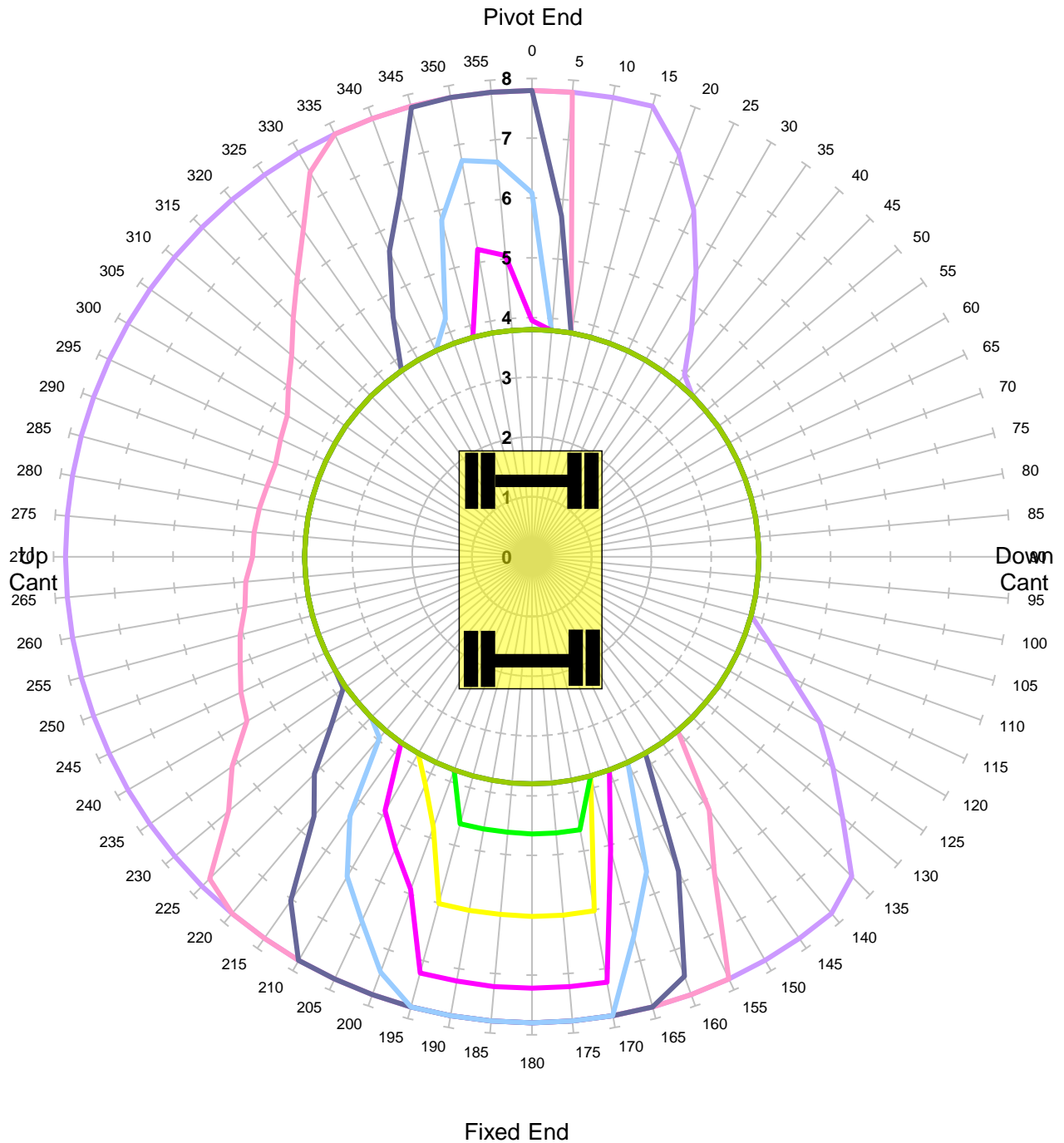

Units in Tonnes

- 1  
 — 2  
 — 3  
 — 4  
 — 5  
 — 6  
 — 7  
 — 8  
 — 9  
 — 10

<b>MACHINE &amp; MODEL:</b>	Colmar T10000FS	<b>REFERENCE:</b>	Dipper Extends by 1000mm
<b>SERIAL No:</b>	8216	<b>DATE OF CHART:</b>	20-May-2019
<b>EQUIPMENT:</b>	4.08m + 2.10m	<b>SAFETY FACTOR:</b>	45.0%
<b>COMMENT:</b>			

# Colmar T10000FS

**Max Capacity Contours of Radius(m) Plots 3.1m Dipper Cwt In  
Gradient 1 in -25 Height 2m Lift BP**

**Unlocked Rail Cant -50mm - Tandem Lift**

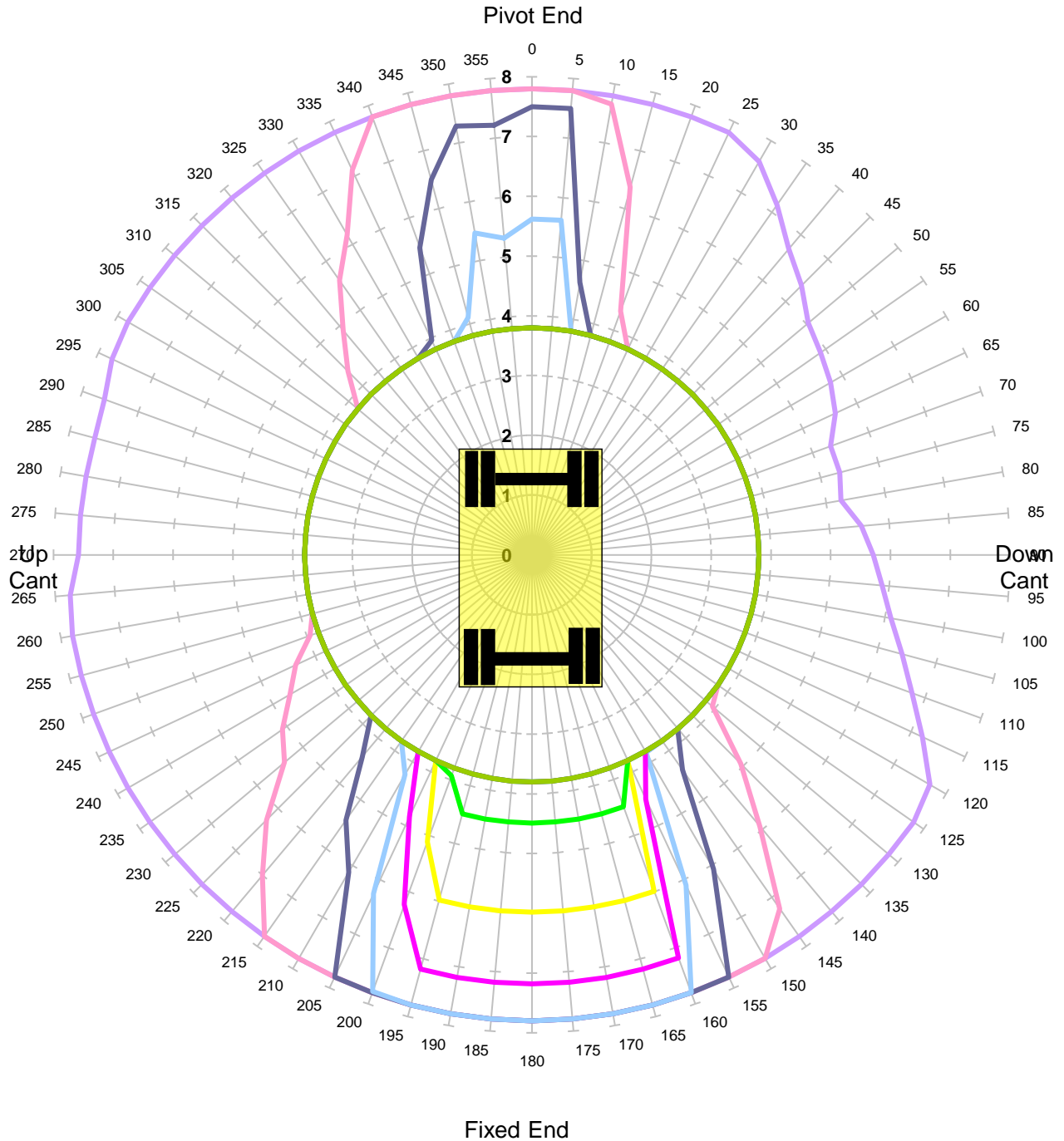

Units in Tonnes

- 1   
 — 2   
 — 3   
 — 4   
 — 5   
 — 6   
 — 7   
 — 8   
 — 9   
 — 10

<b>MACHINE &amp; MODEL:</b>	Colmar T10000FS	<b>REFERENCE:</b>	Dipper Extends by 1000mm
<b>SERIAL No:</b>	8216	<b>DATE OF CHART:</b>	20-May-2019
<b>EQUIPMENT:</b>	4.08m + 2.10m	<b>SAFETY FACTOR:</b>	45.0%
<b>COMMENT:</b>			



## Colmar T10000FS

**Max Capacity Contours of Radius(m) Plots 3.1m Dipper Cwt In  
Gradient 1 in -25 Height 2m Lift BP**

**Unlocked Rail Cant 50mm - Tandem Lift**

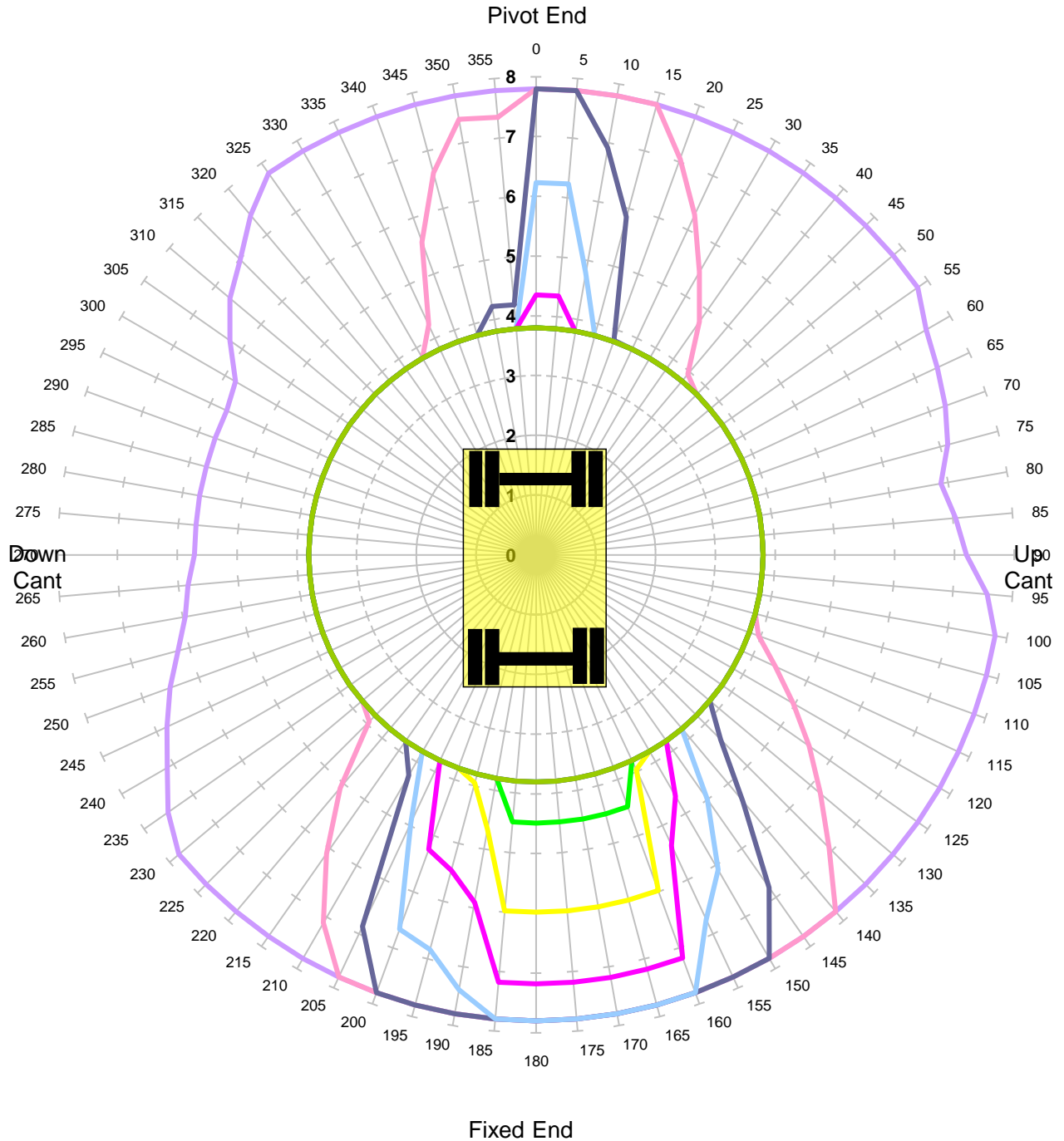

Units in Tonnes

- 1   
 — 2   
 — 3   
 — 4   
 — 5   
 — 6   
 — 7   
 — 8   
 — 9   
 — 10

<b>MACHINE &amp; MODEL:</b>	Colmar T10000FS	<b>REFERENCE:</b>	Dipper Extends by 1000mm
<b>SERIAL No:</b>	8216	<b>DATE OF CHART:</b>	20-May-2019
<b>EQUIPMENT:</b>	4.08m + 2.10m	<b>SAFETY FACTOR:</b>	45.0%
<b>COMMENT:</b>			

## Colmar T10000FS

**Max Capacity Contours of Radius(m) Plots 3.1m Dipper Cwt In  
Gradient 1 in -25 Height 2m Lift BP**

**Unlocked Rail Cant 150mm - Tandem Lift**

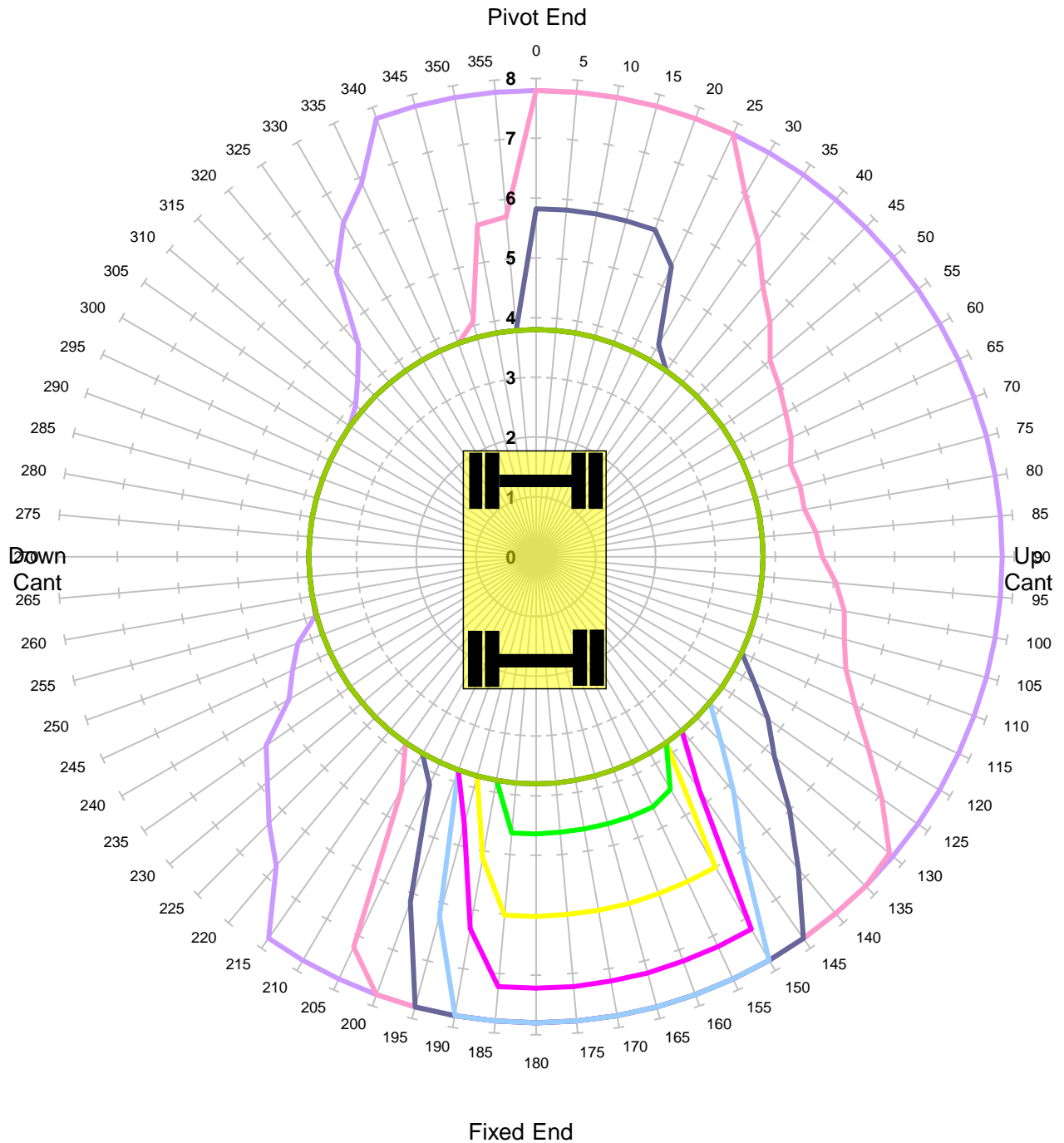

Units in Tonnes

— 1  
 — 2  
 — 3  
 — 4  
 — 5  
 — 6  
 — 7  
 — 8  
 — 9  
 — 10

<b>MACHINE &amp; MODEL:</b>	Colmar T10000FS	<b>REFERENCE:</b>	Dipper Extends by 1000mm
<b>SERIAL No:</b>	8216	<b>DATE OF CHART:</b>	20-May-2019
<b>EQUIPMENT:</b>	4.08m + 2.10m	<b>SAFETY FACTOR:</b>	45.0%
<b>COMMENT:</b>			

# Colmar T10000FS

**Max Capacity Contours of Radius(m) Plots 3.1m Dipper Cwt In  
Gradient 1 in -25 Height 2m Lift BP**

**Locked Rail Cant -150mm - Tandem Lift**

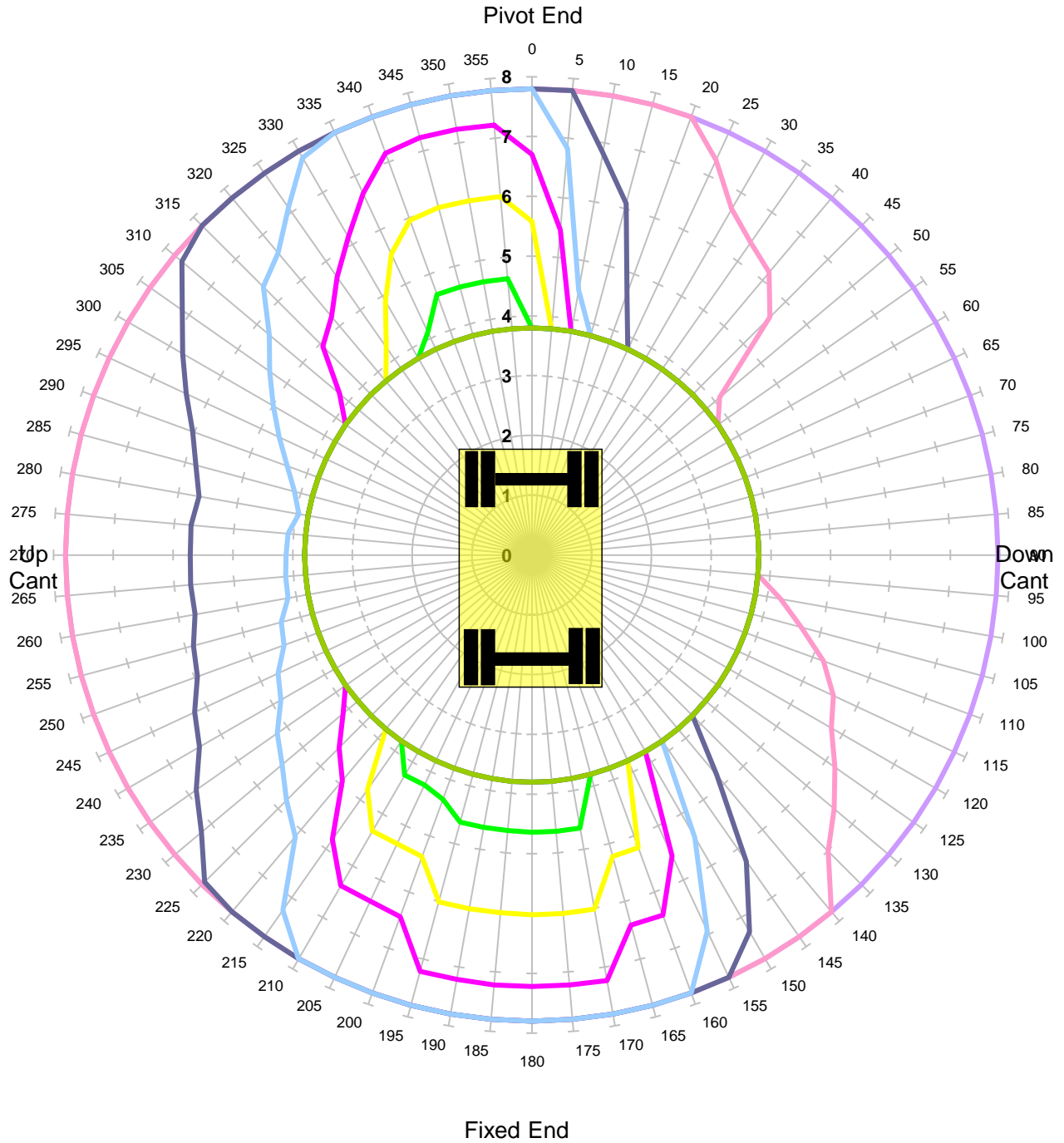

<b>MACHINE &amp; MODEL:</b>	Colmar T10000FS	<b>REFERENCE:</b>	Dipper Extends by 1000mm
<b>SERIAL No:</b>	8216	<b>DATE OF CHART:</b>	20-May-2019
<b>EQUIPMENT:</b>	4.08m + 2.10m	<b>SAFETY FACTOR:</b>	60.0%
<b>COMMENT:</b>			

## Colmar T10000FS

**Max Capacity Contours of Radius(m) Plots 3.1m Dipper Cwt In  
Gradient 1 in -25 Height 2m Lift BP**

**Locked Rail Cant -50mm - Tandem Lift**

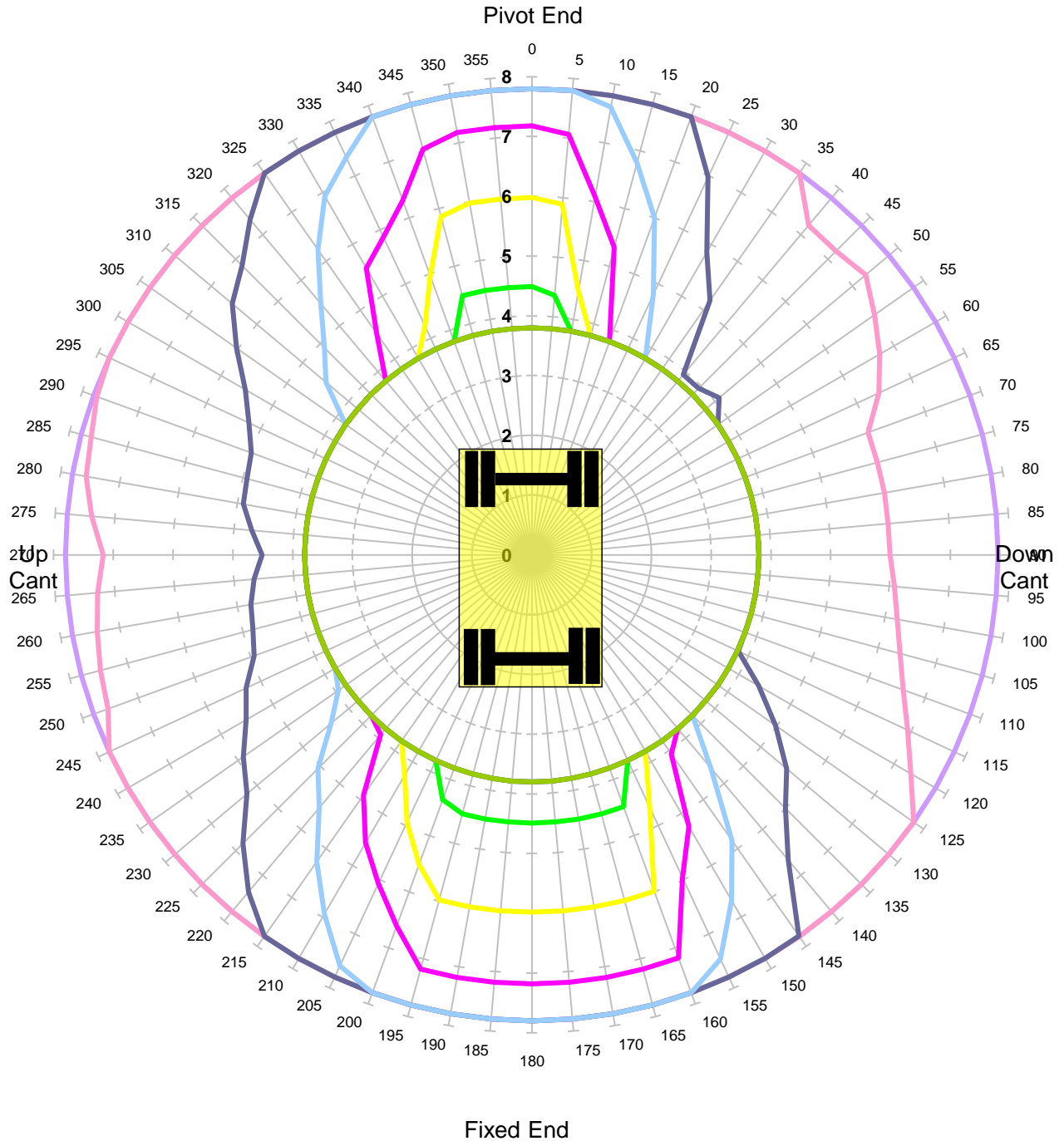

Units in Tonnes

- 1  
 — 2  
 — 3  
 — 4  
 — 5  
 — 6  
 — 7  
 — 8  
 — 9  
 — 10

<b>MACHINE &amp; MODEL:</b>	Colmar T10000FS	<b>REFERENCE:</b>	Dipper Extends by 1000mm
<b>SERIAL No:</b>	8216	<b>DATE OF CHART:</b>	20-May-2019
<b>EQUIPMENT:</b>	4.08m + 2.10m	<b>SAFETY FACTOR:</b>	60.0%
<b>COMMENT:</b>			

## Colmar T10000FS

**Max Capacity Contours of Radius(m) Plots 3.1m Dipper Cwt In  
Gradient 1 in -25 Height 2m Lift BP**

**Locked Rail Cant 50mm - Tandem Lift**

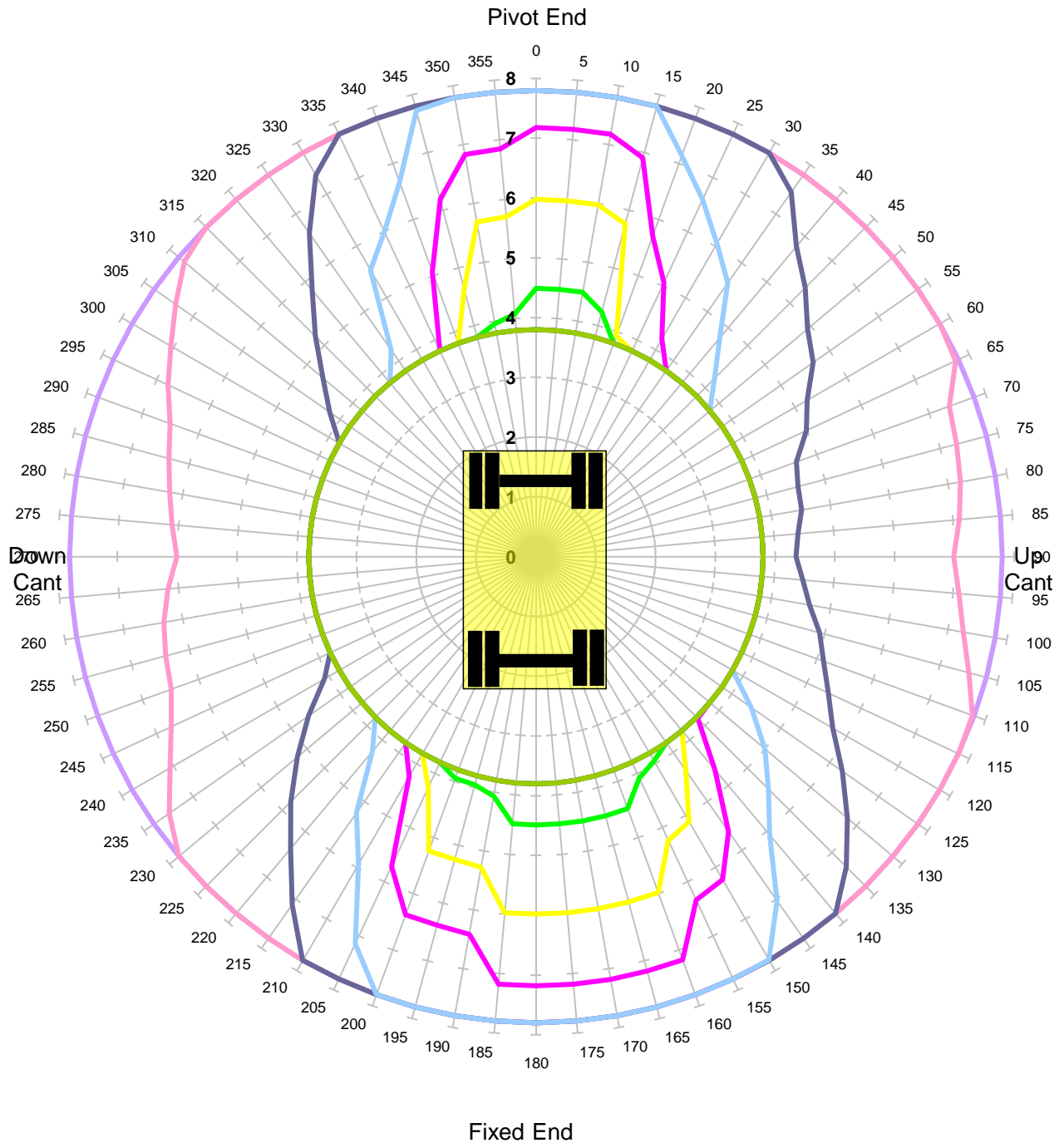

<b>MACHINE &amp; MODEL:</b>	Colmar T10000FS	<b>REFERENCE:</b>	Dipper Extends by 1000mm
<b>SERIAL No:</b>	8216	<b>DATE OF CHART:</b>	20-May-2019
<b>EQUIPMENT:</b>	4.08m + 2.10m	<b>SAFETY FACTOR:</b>	60.0%
<b>COMMENT:</b>			

## Colmar T10000FS

**Max Capacity Contours of Radius(m) Plots 3.1m Dipper Cwt In  
Gradient 1 in -25 Height 2m Lift BP**

**Locked Rail Cant 150mm - Tandem Lift**

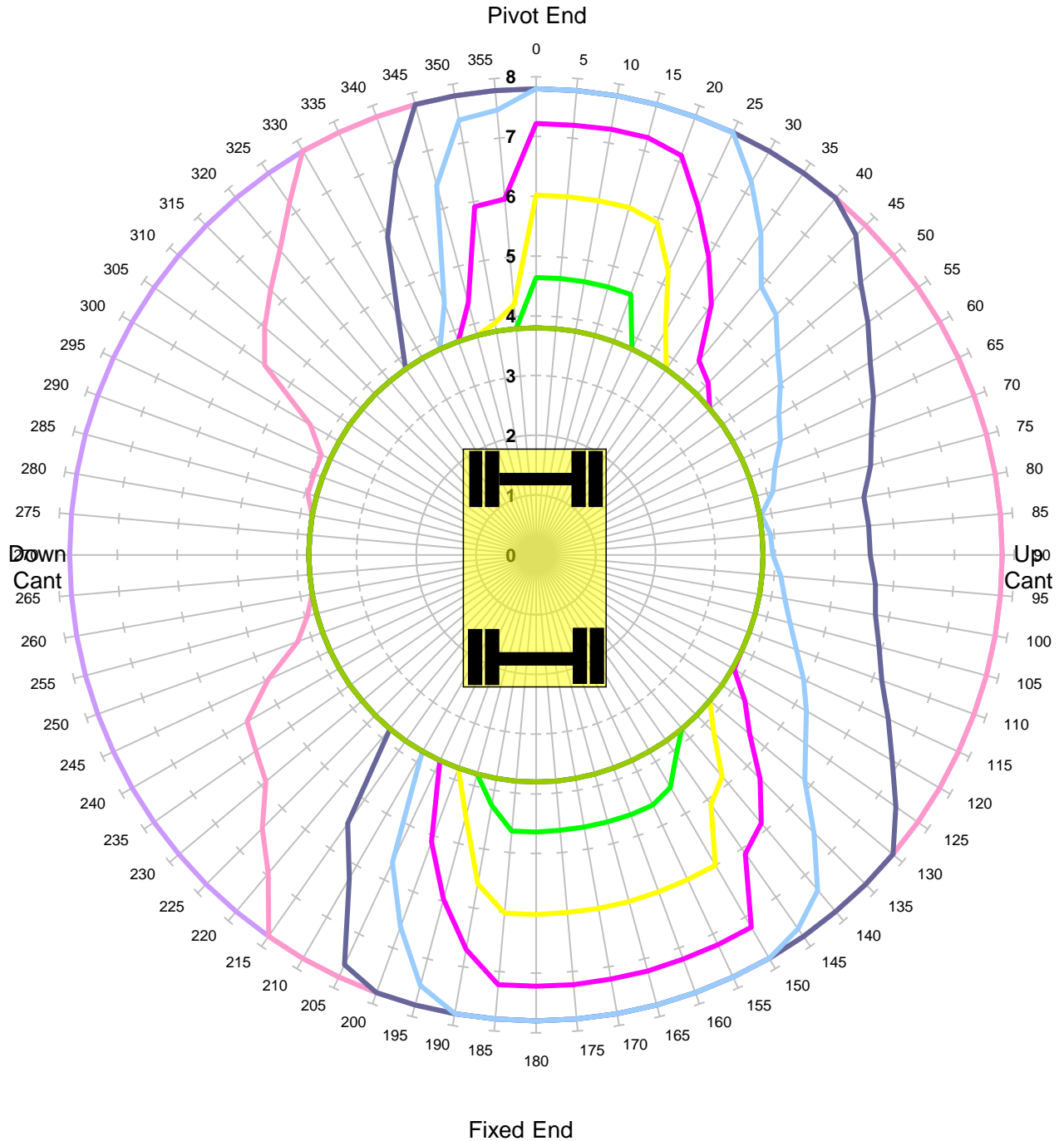

Units in Tonnes

- 1  
 — 2  
 — 3  
 — 4  
 — 5  
 — 6  
 — 7  
 — 8  
 — 9  
 — 10

<b>MACHINE &amp; MODEL:</b>	Colmar T10000FS	<b>REFERENCE:</b>	Dipper Extends by 1000mm
<b>SERIAL No:</b>	8216	<b>DATE OF CHART:</b>	20-May-2019
<b>EQUIPMENT:</b>	4.08m + 2.10m	<b>SAFETY FACTOR:</b>	60.0%
<b>COMMENT:</b>			



## Colmar T10000FS

**Max Capacity Contours of Radius(m) Plots 3.1m Dipper Cwt In  
Level Ground Height 2m Lift BP  
Unlocked Road - Tandem Lift**

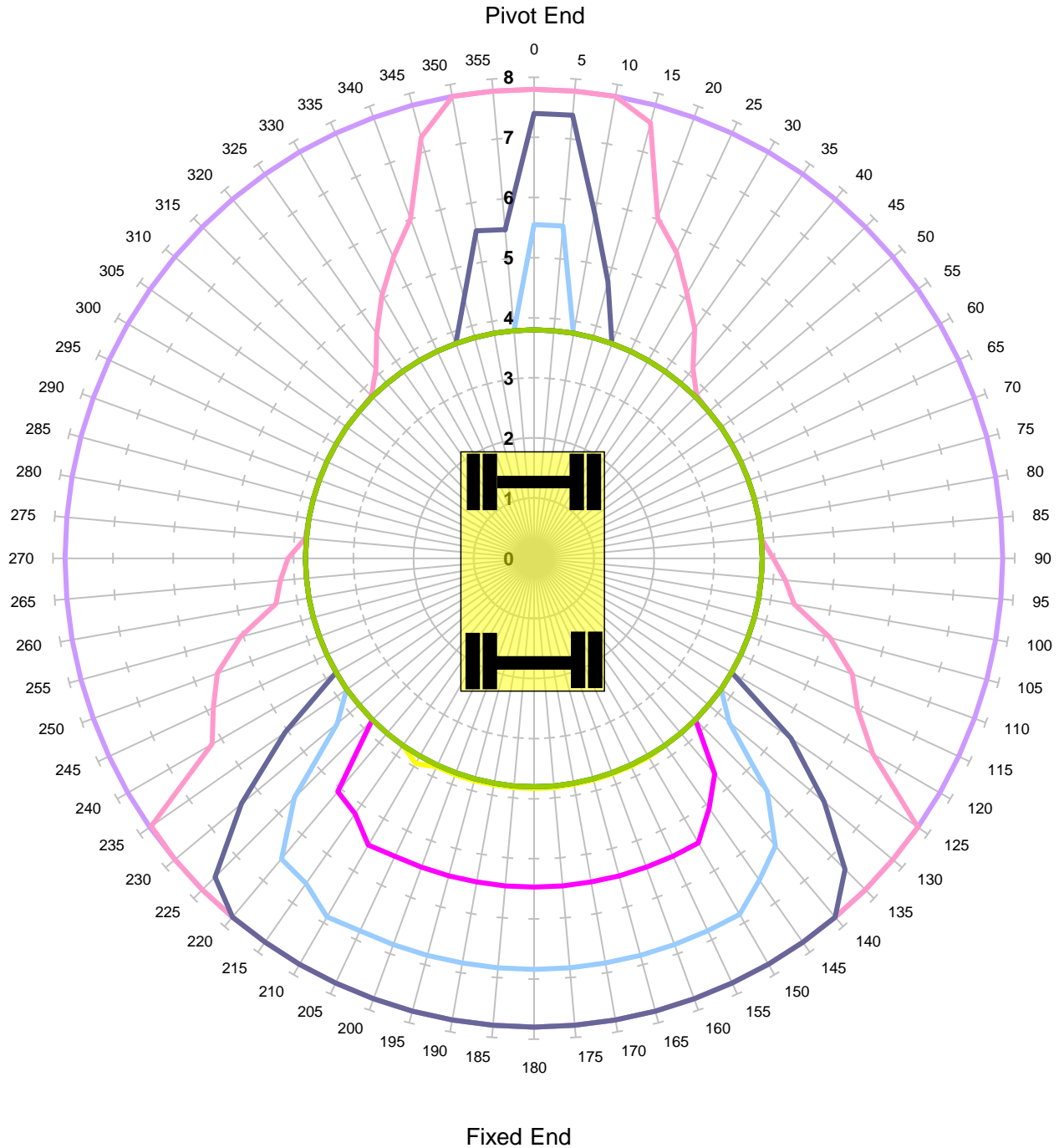

Units in Tonnes

— 1   
 — 2   
 — 3   
 — 4   
 — 5   
 — 6   
 — 7   
 — 8   
 — 9   
 — 10

<b>MACHINE &amp; MODEL:</b>	Colmar T10000FS	<b>REFERENCE:</b>	Dipper Extends by 1000mm
<b>SERIAL No:</b>	8216	<b>DATE OF CHART:</b>	20-May-2019
<b>EQUIPMENT:</b>	4.08m + 2.10m	<b>SAFETY FACTOR:</b>	47.0%
<b>COMMENT:</b>			

**Colmar T10000FS**  
**Max Capacity Contours of Radius(m) Plots 3.1m Dipper Cwt In**  
**Level Ground Height 2m Lift BP**  
**Locked Road - Tandem Lift**

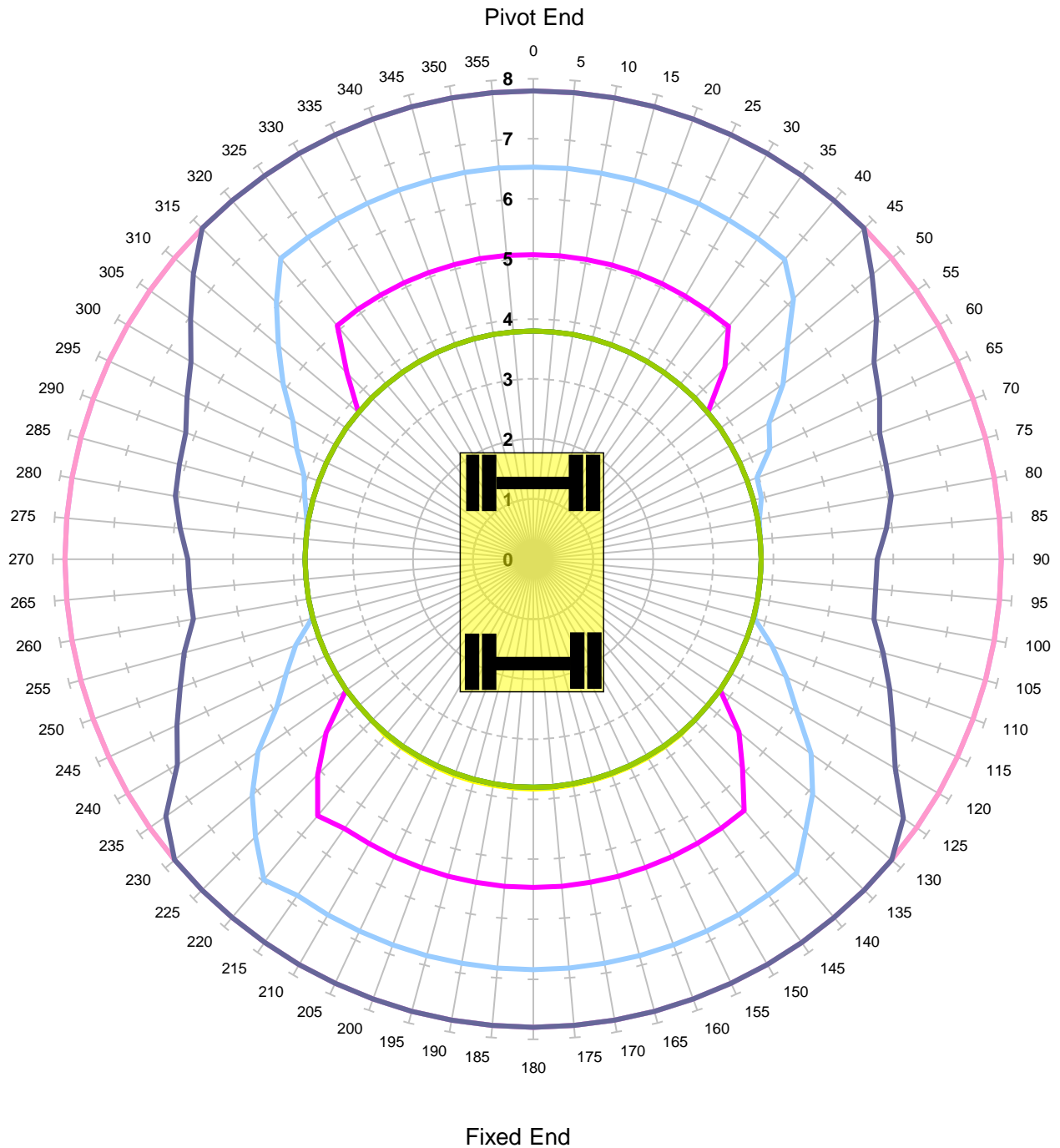

Units in Tonnes

- 1   
 — 2   
 — 3   
 — 4   
 — 5   
 — 6   
 — 7   
 — 8   
 — 9   
 — 10

<b>MACHINE &amp; MODEL:</b>	Colmar T10000FS	<b>REFERENCE:</b>	Dipper Extends by 1000mm
<b>SERIAL No:</b>	8216	<b>DATE OF CHART:</b>	20-May-2019
<b>EQUIPMENT:</b>	4.08m + 2.10m	<b>SAFETY FACTOR:</b>	47.0%
<b>COMMENT:</b>			

**Colmar T10000FS**  
**Max Capacity Contours of Radius(m) Plots 2.1m Dipper Cwt Out**  
**Gradient 1 in -25 Height 2m Lift BP**  
**Unlocked Rail Cant -150mm**

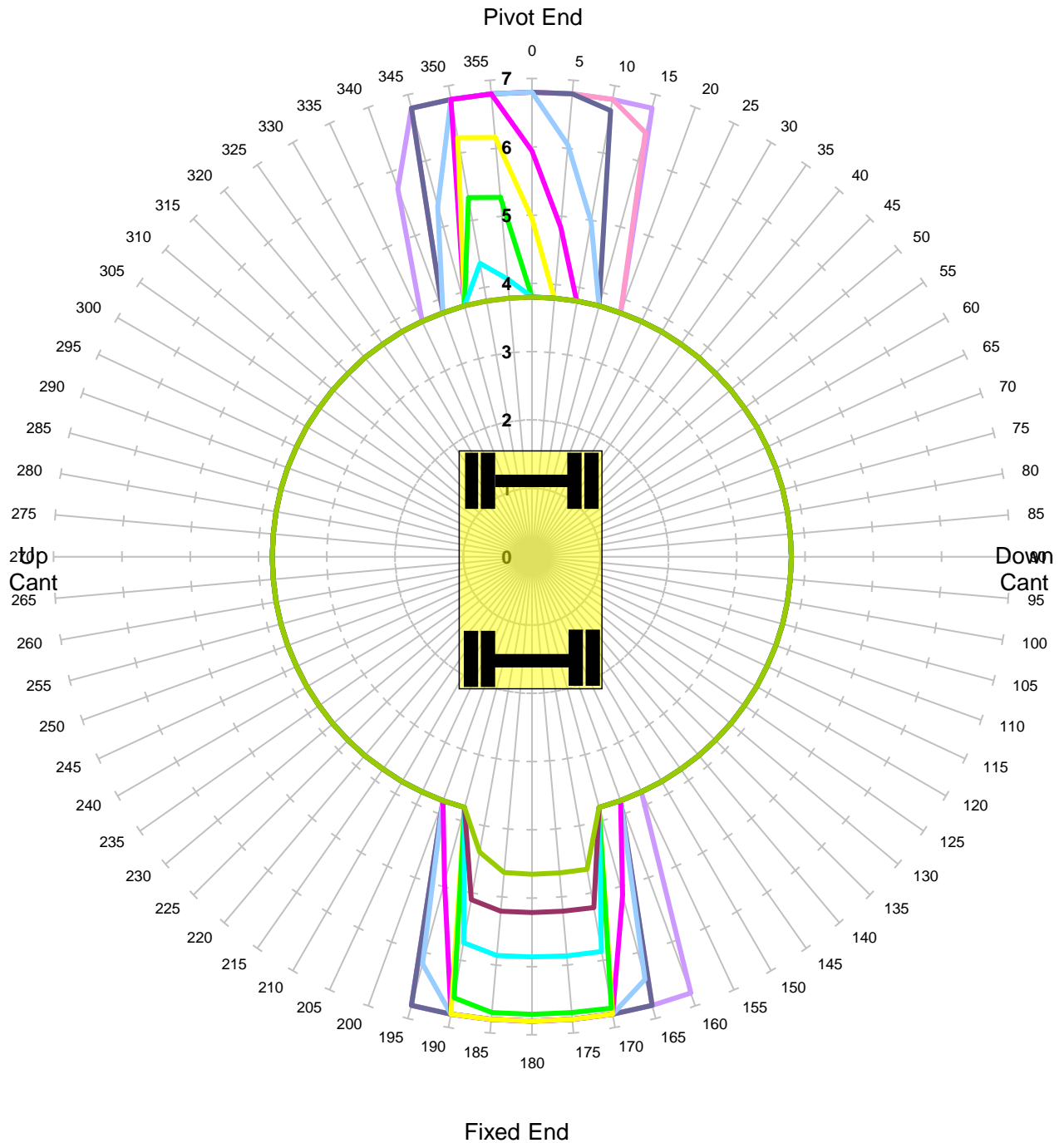

Units in Tonnes

- 1
- 2
- 3
- 4
- 5
- 6
- 7
- 8
- 9
- 10

<b>MACHINE &amp; MODEL:</b>	Colmar T10000FS	<b>REFERENCE:</b>	Dipper Extends by 1000mm
<b>SERIAL No:</b>	8216	<b>DATE OF CHART:</b>	20-May-2019
<b>EQUIPMENT:</b>	4.08m + 2.10m	<b>SAFETY FACTOR:</b>	67.0%
<b>COMMENT:</b>			

**Colmar T10000FS**  
**Max Capacity Contours of Radius(m) Plots 2.1m Dipper Cwt Out**  
**Gradient 1 in -25 Height 2m Lift BP**  
**Unlocked Rail Cant -50mm**

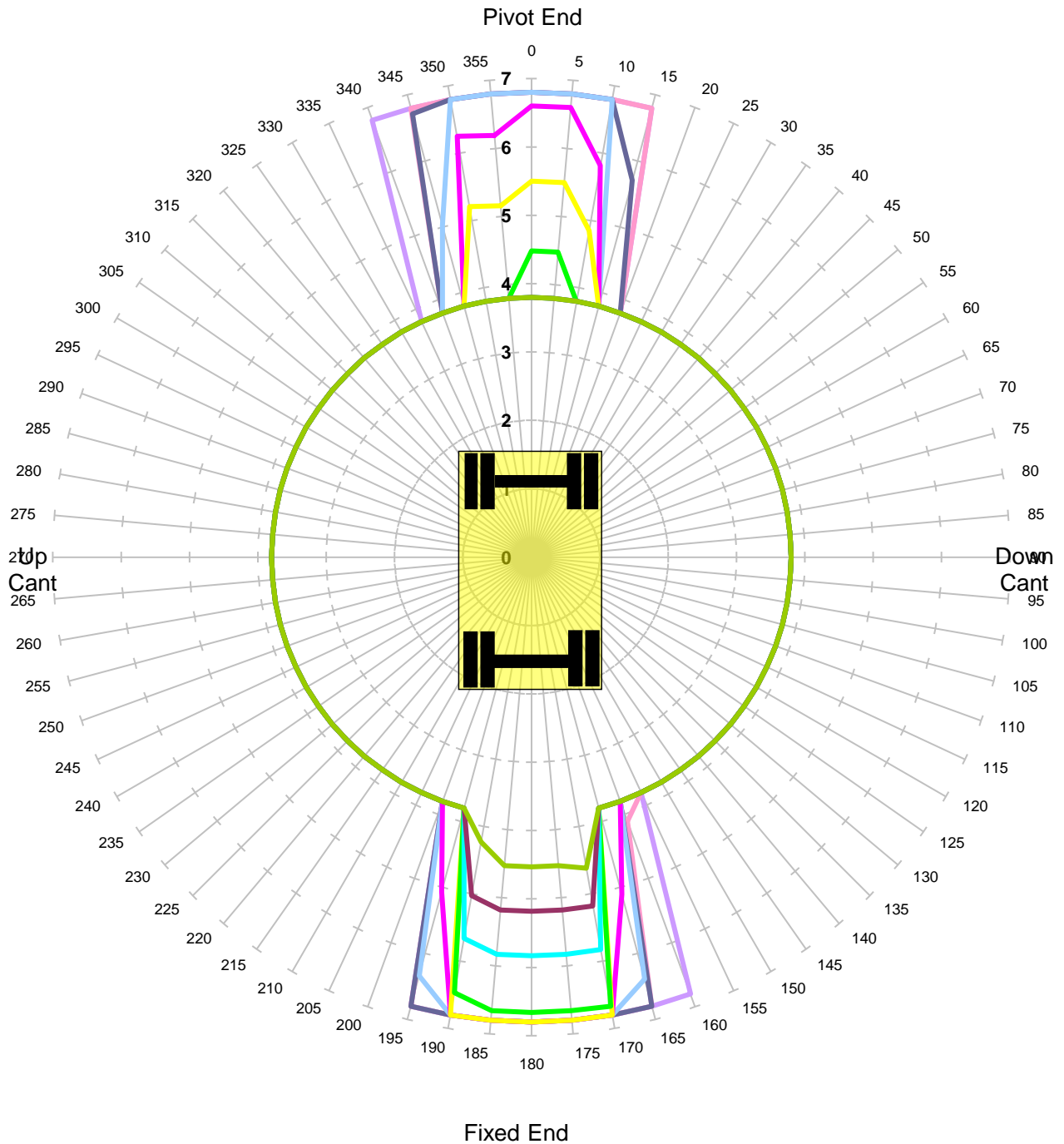

<b>MACHINE &amp; MODEL:</b>	Colmar T10000FS	<b>REFERENCE:</b>	Dipper Extends by 1000mm
<b>SERIAL No:</b>	8216	<b>DATE OF CHART:</b>	20-May-2019
<b>EQUIPMENT:</b>	4.08m + 2.10m	<b>SAFETY FACTOR:</b>	67.0%
<b>COMMENT:</b>			

## Colmar T10000FS

**Max Capacity Contours of Radius(m) Plots 2.1m Dipper Cwt Out  
Gradient 1 in -25 Height 2m Lift BP**

**Unlocked Rail Cant 50mm**

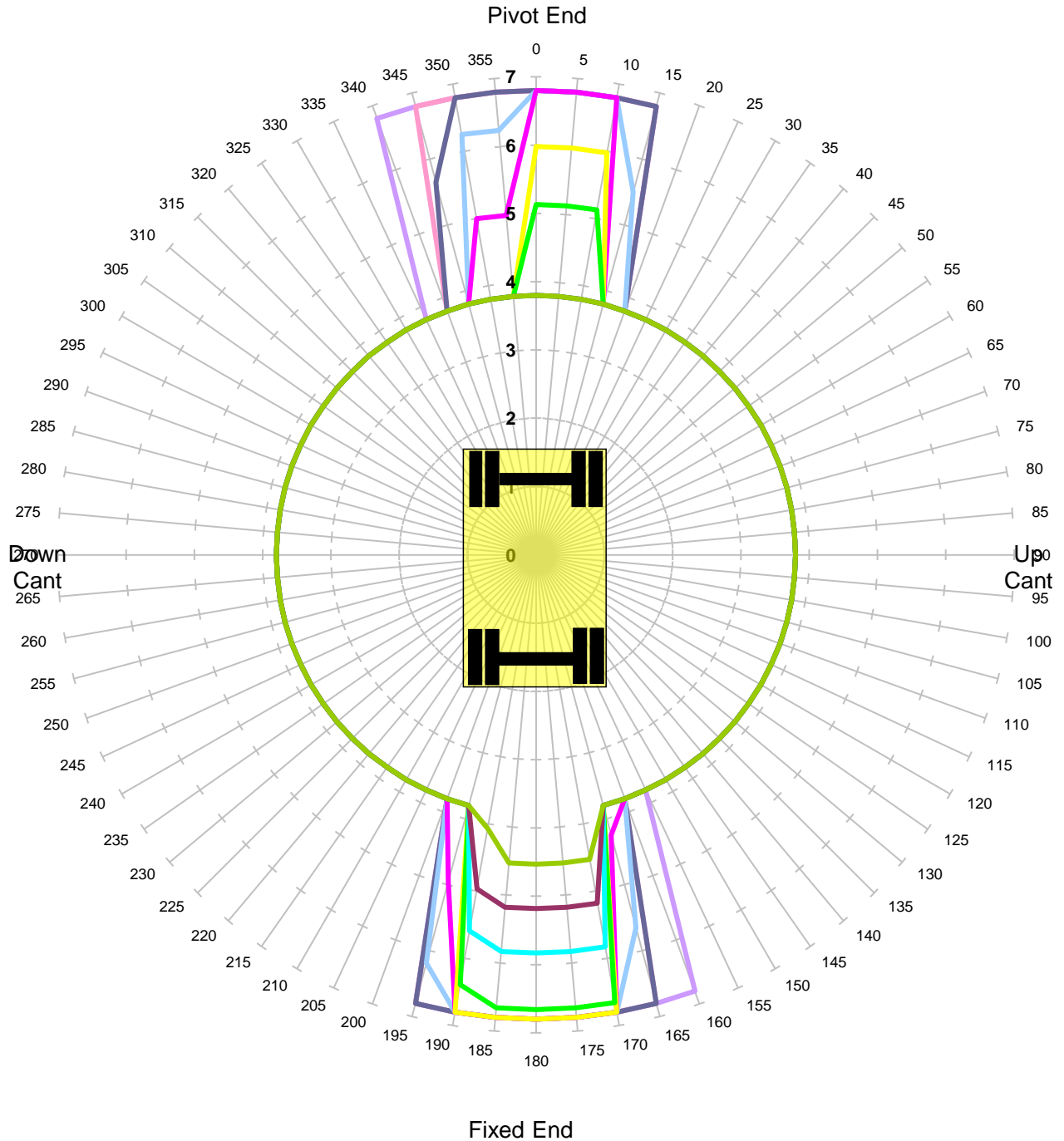

Units in Tonnes

1 2 3 4 5 6 7 8 9 10

<b>MACHINE &amp; MODEL:</b>	Colmar T10000FS	<b>REFERENCE:</b>	Dipper Extends by 1000mm
<b>SERIAL No:</b>	8216	<b>DATE OF CHART:</b>	20-May-2019
<b>EQUIPMENT:</b>	4.08m + 2.10m	<b>SAFETY FACTOR:</b>	67.0%
<b>COMMENT:</b>			

**Colmar T10000FS**  
**Max Capacity Contours of Radius(m) Plots 2.1m Dipper Cwt Out**  
**Gradient 1 in -25 Height 2m Lift BP**  
**Unlocked Rail Cant 150mm**

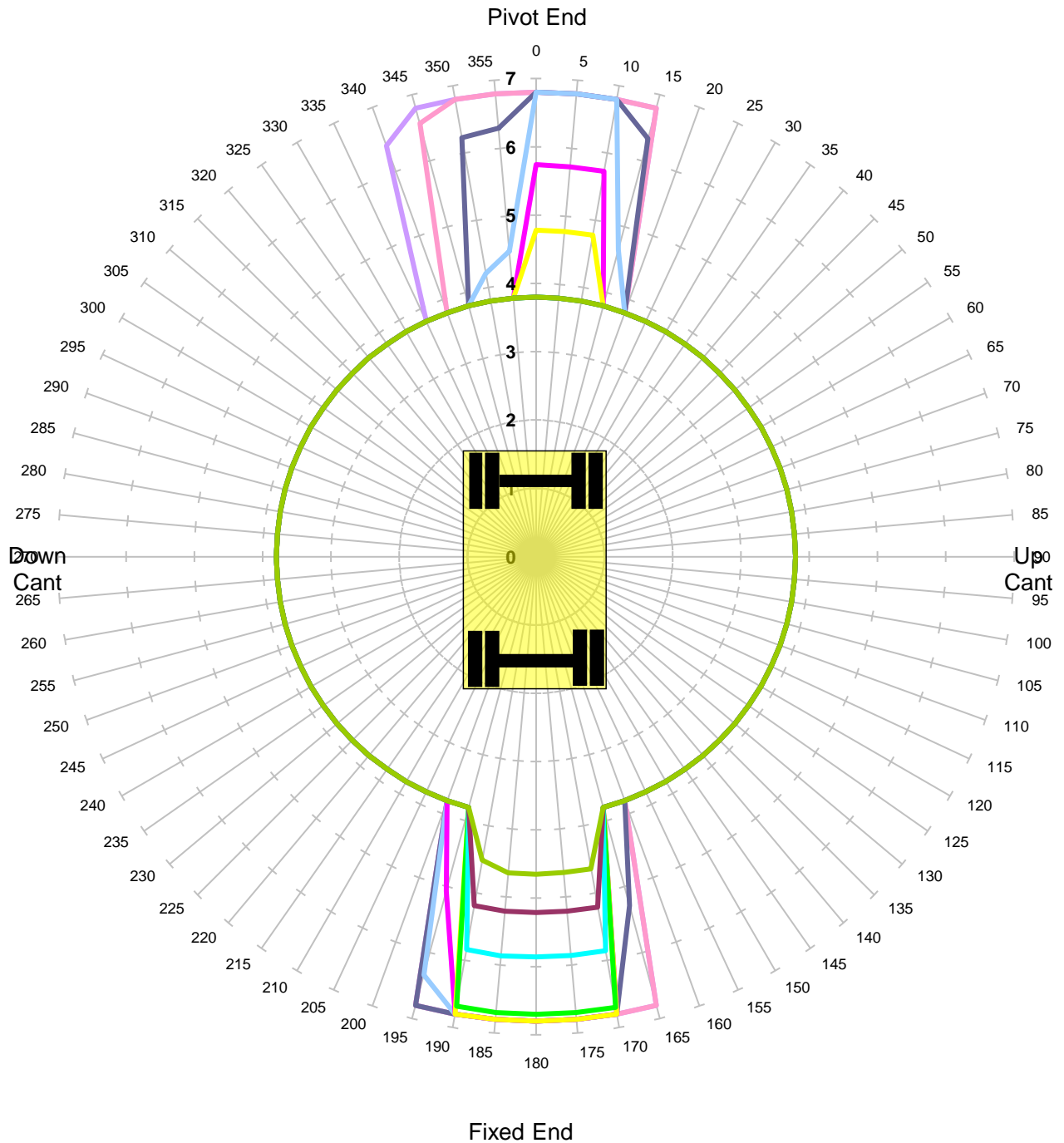

Units in Tonnes

- 1
- 2
- 3
- 4
- 5
- 6
- 7
- 8
- 9
- 10

<b>MACHINE &amp; MODEL:</b>	Colmar T10000FS	<b>REFERENCE:</b>	Dipper Extends by 1000mm
<b>SERIAL No:</b>	8216	<b>DATE OF CHART:</b>	20-May-2019
<b>EQUIPMENT:</b>	4.08m + 2.10m	<b>SAFETY FACTOR:</b>	67.0%
<b>COMMENT:</b>			



**Colmar T10000FS**  
**Max Capacity Contours of Radius(m) Plots 2.1m Dipper Cwt Out**  
**Gradient 1 in -25 Height 2m Lift BP**  
**Locked Rail Cant -150mm**

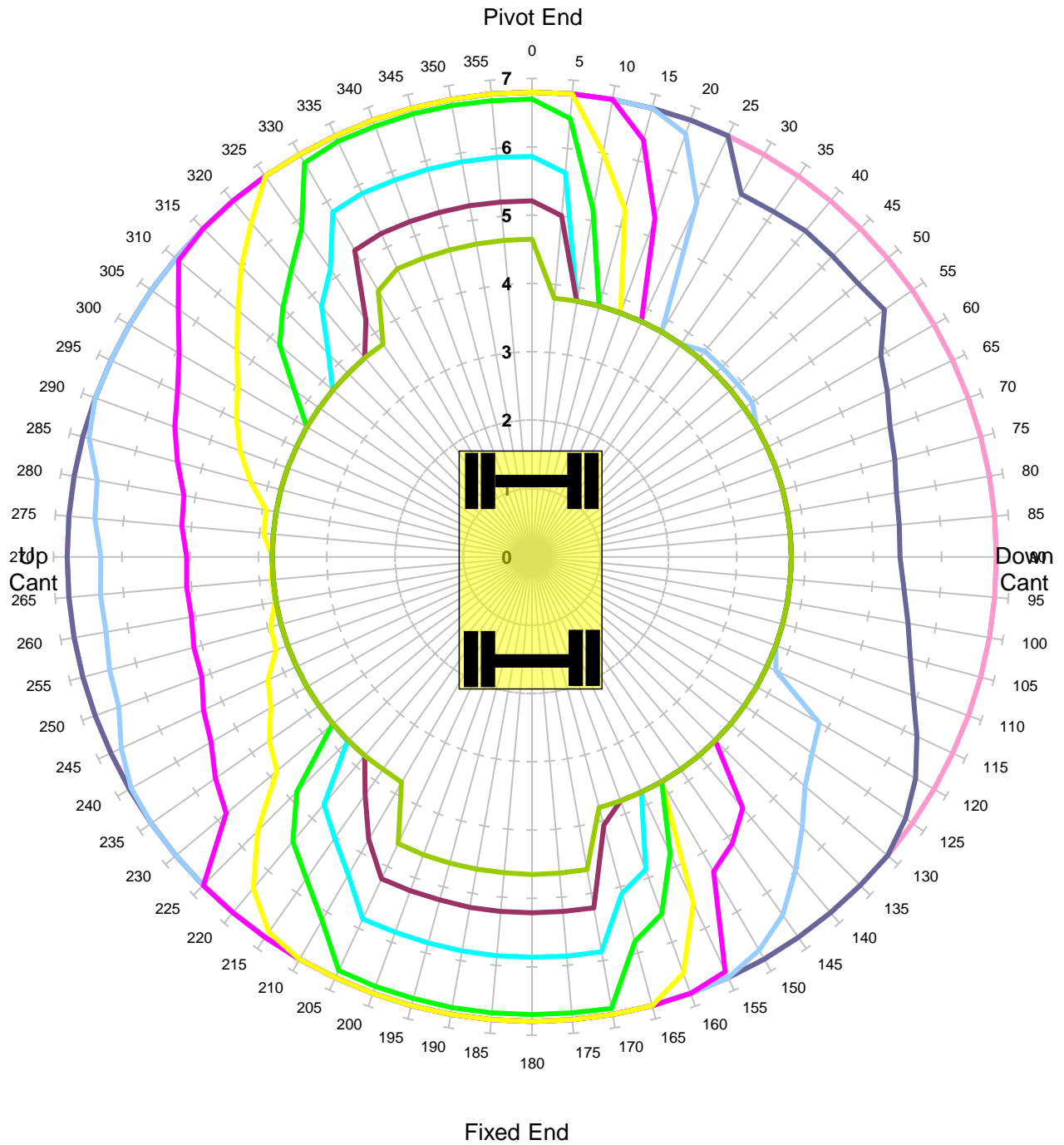

<b>MACHINE &amp; MODEL:</b>	Colmar T10000FS	<b>REFERENCE:</b>	Dipper Extends by 1000mm
<b>SERIAL No:</b>	8216	<b>DATE OF CHART:</b>	20-May-2019
<b>EQUIPMENT:</b>	4.08m + 2.10m	<b>SAFETY FACTOR:</b>	90.0%
<b>COMMENT:</b>			

**Colmar T10000FS**  
**Max Capacity Contours of Radius(m) Plots 2.1m Dipper Cwt Out**  
**Gradient 1 in -25 Height 2m Lift BP**  
**Locked Rail Cant -50mm**

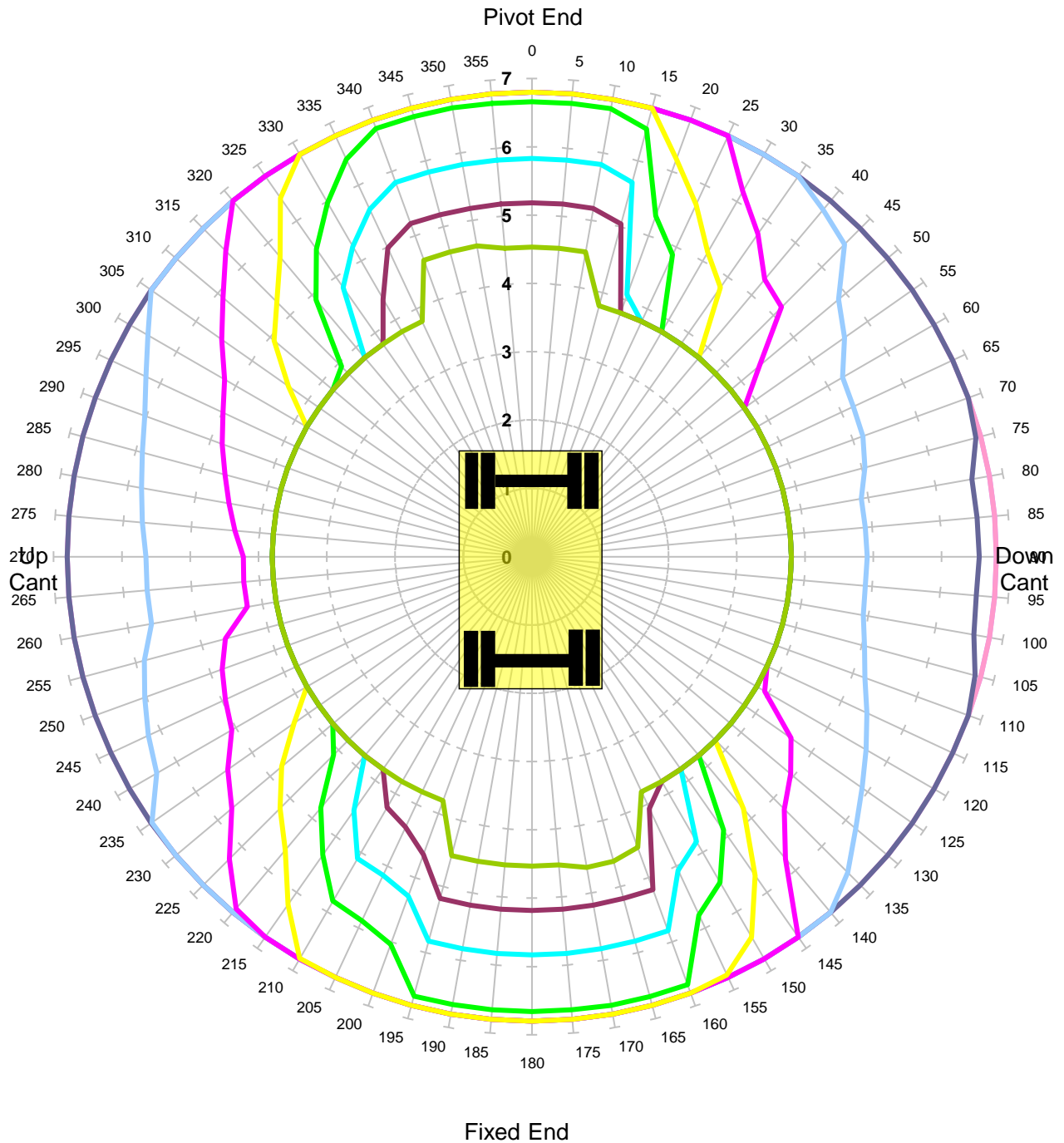

Units in Tonnes

- 1
- 2
- 3
- 4
- 5
- 6
- 7
- 8
- 9
- 10

<b>MACHINE &amp; MODEL:</b>	Colmar T10000FS	<b>REFERENCE:</b>	Dipper Extends by 1000mm
<b>SERIAL No:</b>	8216	<b>DATE OF CHART:</b>	20-May-2019
<b>EQUIPMENT:</b>	4.08m + 2.10m	<b>SAFETY FACTOR:</b>	90.0%
<b>COMMENT:</b>			

**Colmar T10000FS**  
**Max Capacity Contours of Radius(m) Plots 2.1m Dipper Cwt Out**  
**Gradient 1 in -25 Height 2m Lift BP**  
**Locked Rail Cant 50mm**

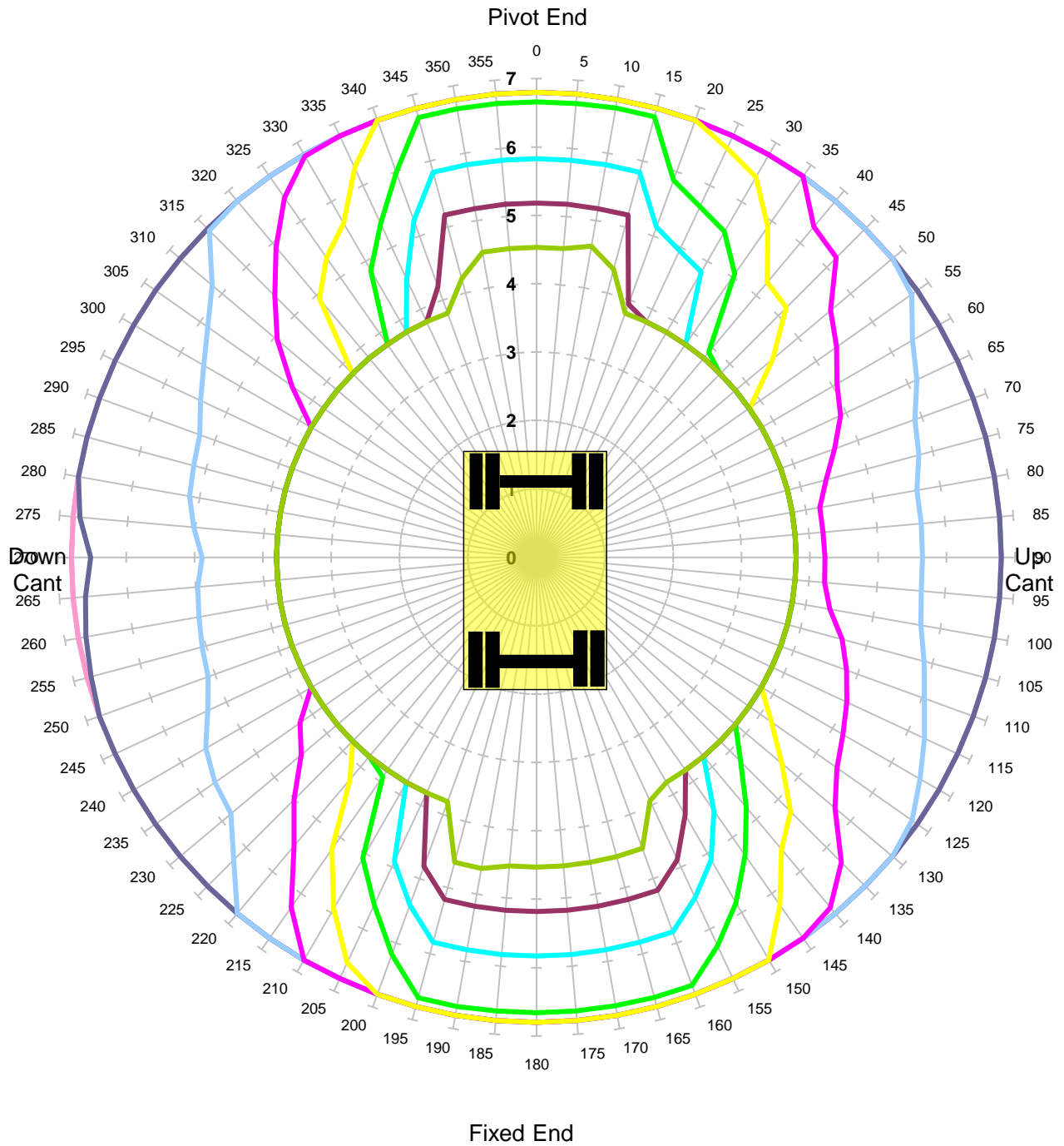

Units in Tonnes

- 1
- 2
- 3
- 4
- 5
- 6
- 7
- 8
- 9
- 10

<b>MACHINE &amp; MODEL:</b>	Colmar T10000FS	<b>REFERENCE:</b>	Dipper Extends by 1000mm
<b>SERIAL No:</b>	8216	<b>DATE OF CHART:</b>	20-May-2019
<b>EQUIPMENT:</b>	4.08m + 2.10m	<b>SAFETY FACTOR:</b>	90.0%
<b>COMMENT:</b>			

**Colmar T10000FS**  
**Max Capacity Contours of Radius(m) Plots 2.1m Dipper Cwt Out**  
**Gradient 1 in -25 Height 2m Lift BP**  
**Locked Rail Cant 150mm**

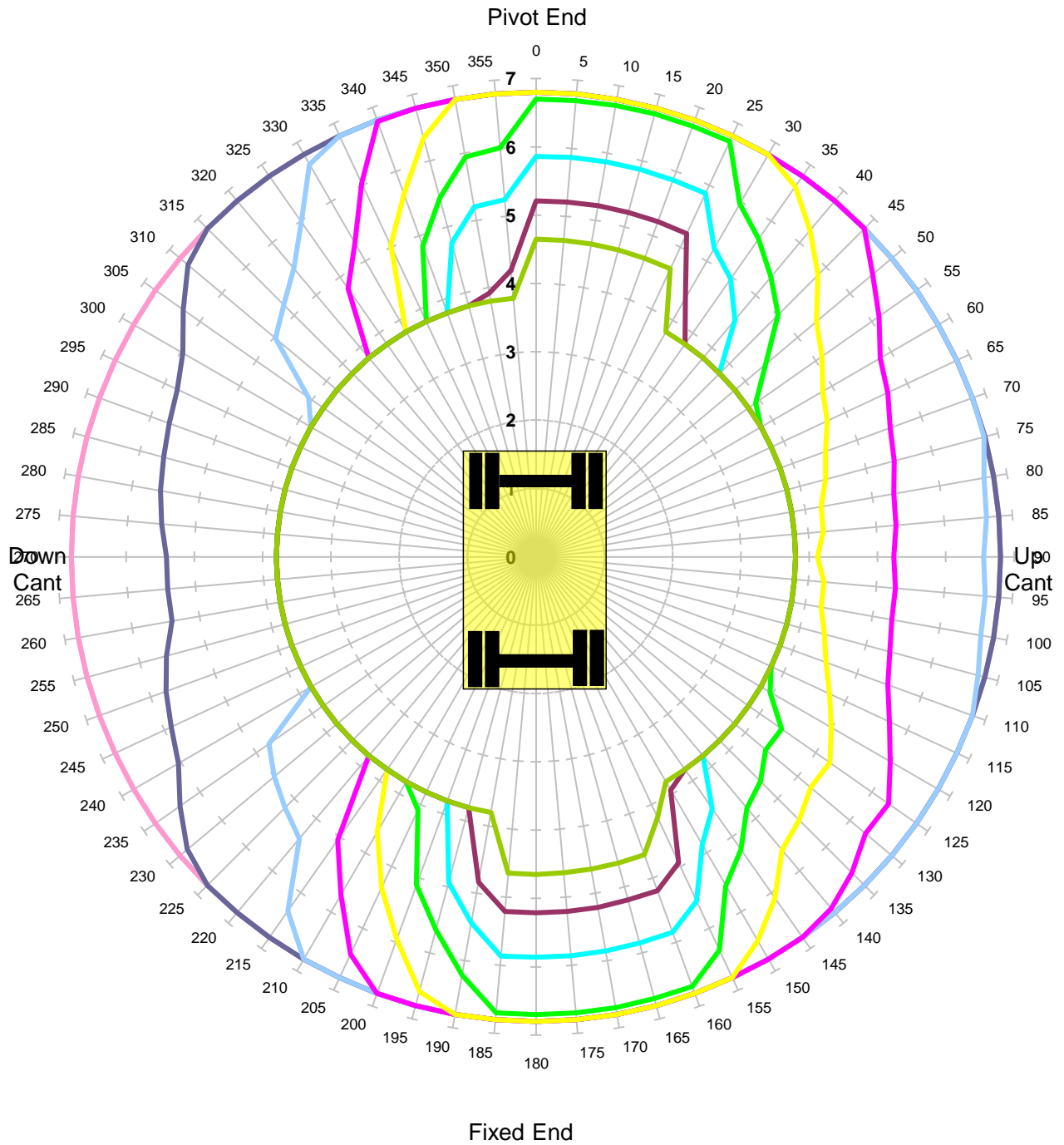

Units in Tonnes

- 1
- 2
- 3
- 4
- 5
- 6
- 7
- 8
- 9
- 10

<b>MACHINE &amp; MODEL:</b>	Colmar T10000FS	<b>REFERENCE:</b>	Dipper Extends by 1000mm
<b>SERIAL No:</b>	8216	<b>DATE OF CHART:</b>	20-May-2019
<b>EQUIPMENT:</b>	4.08m + 2.10m	<b>SAFETY FACTOR:</b>	90.0%
<b>COMMENT:</b>			

**Colmar T10000FS**  
**Max Capacity Contours of Radius(m) Plots 2.1m Dipper Cwt Out**  
**Level Ground Height 2m Lift BP**  
**Unlocked Road**

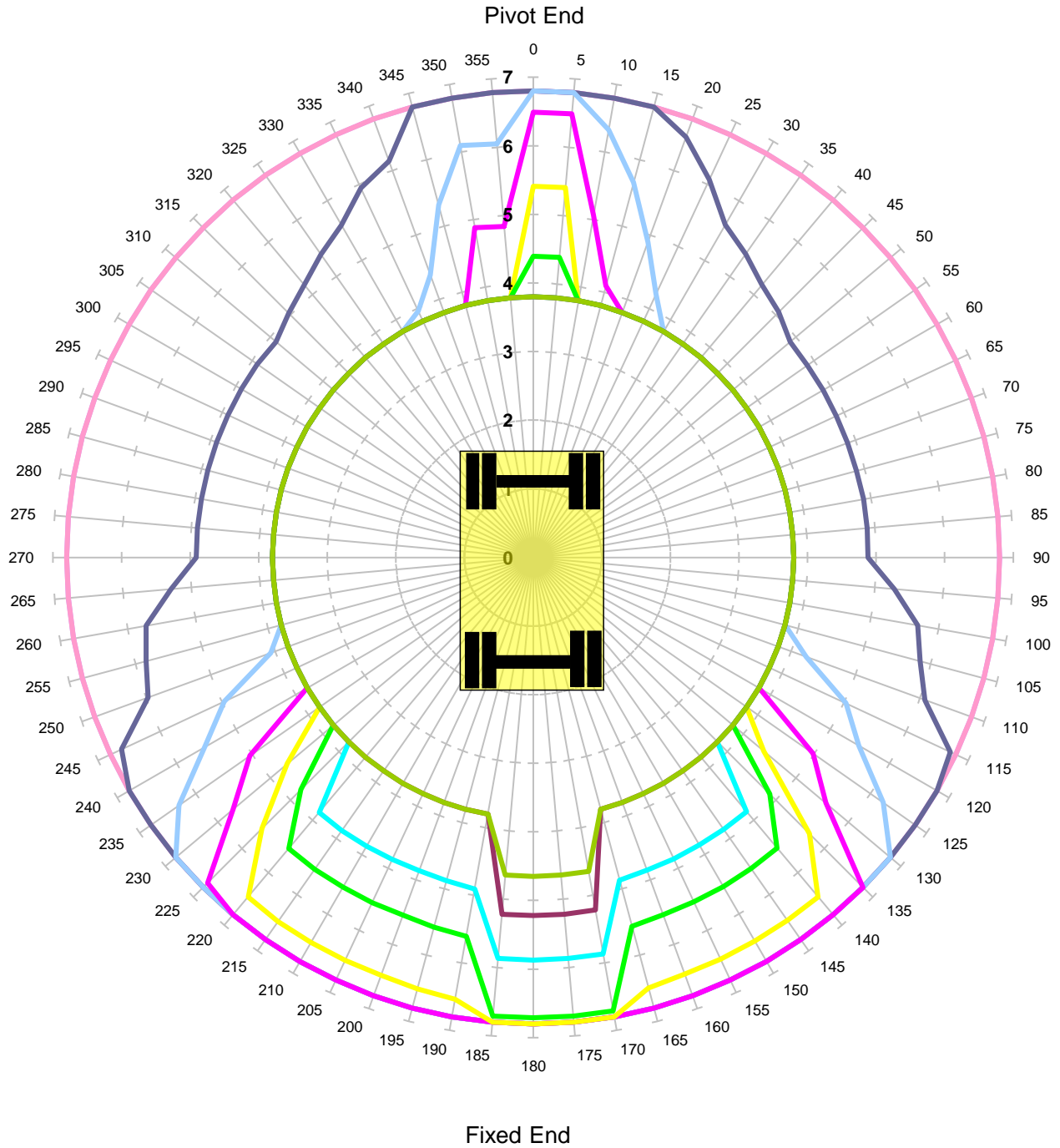

Units in Tonnes

- 1
- 2
- 3
- 4
- 5
- 6
- 7
- 8
- 9
- 10

<b>MACHINE &amp; MODEL:</b>	Colmar T10000FS	<b>REFERENCE:</b>	Dipper Extends by 1000mm
<b>SERIAL No:</b>	8216	<b>DATE OF CHART:</b>	20-May-2019
<b>EQUIPMENT:</b>	4.08m + 2.10m	<b>SAFETY FACTOR:</b>	71.0%
<b>COMMENT:</b>			

# Colmar T10000FS

**Max Capacity Contours of Radius(m) Plots 2.1m Dipper Cwt Out  
Level Ground Height 2m Lift BP**

**Locked Road**

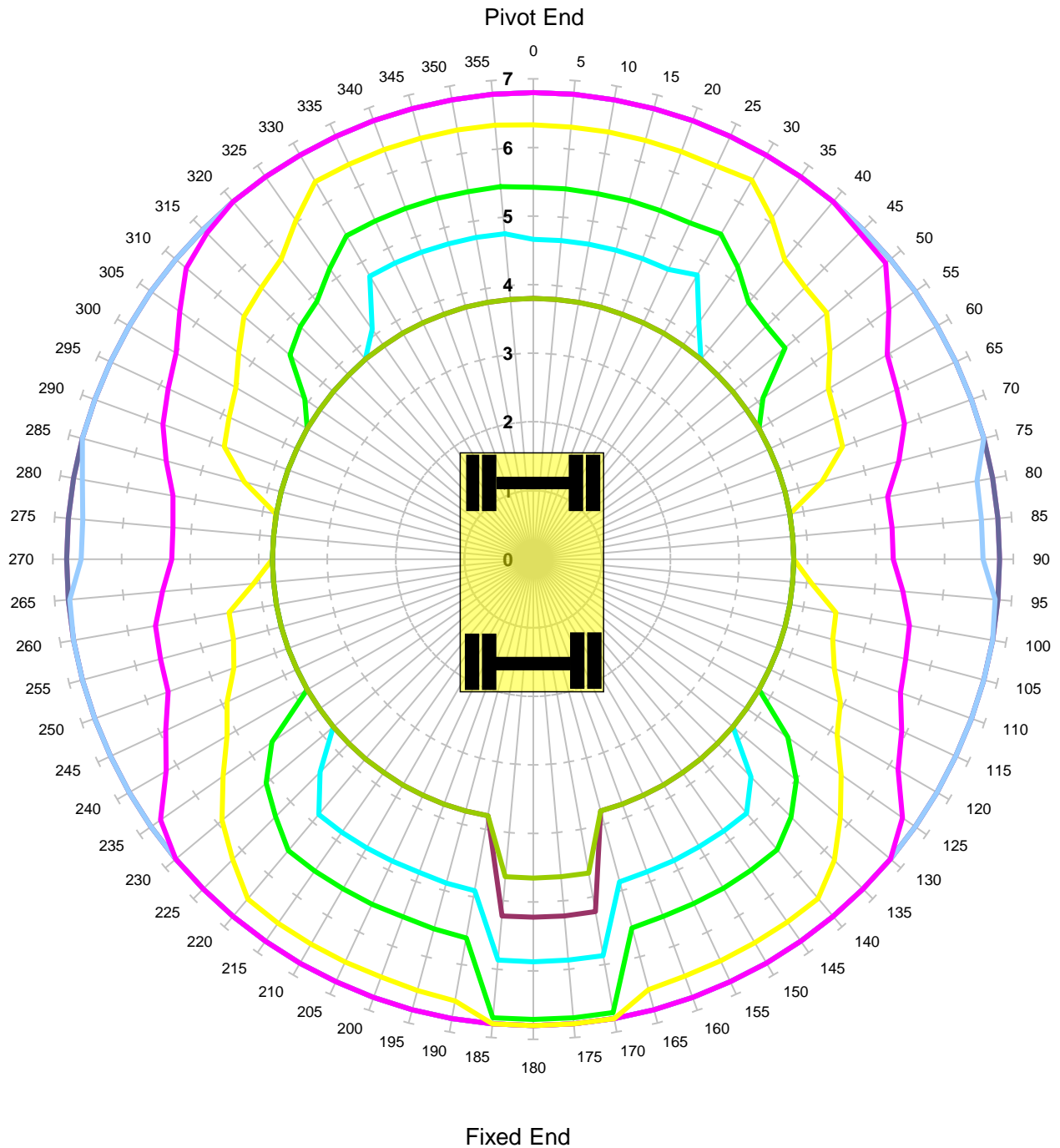

Units in Tonnes

- 1
- 2
- 3
- 4
- 5
- 6
- 7
- 8
- 9
- 10

<b>MACHINE &amp; MODEL:</b>	Colmar T10000FS	<b>REFERENCE:</b>	Dipper Extends by 1000mm
<b>SERIAL No:</b>	8216	<b>DATE OF CHART:</b>	20-May-2019
<b>EQUIPMENT:</b>	4.08m + 2.10m	<b>SAFETY FACTOR:</b>	71.0%
<b>COMMENT:</b>			



## Colmar T10000FS

**Max Capacity Contours of Radius(m) Plots 2.1m Dipper Cwt Out  
Gradient 1 in -25 Height 2m Lift BP**

**Unlocked Rail Cant -150mm - Tandem Lift**

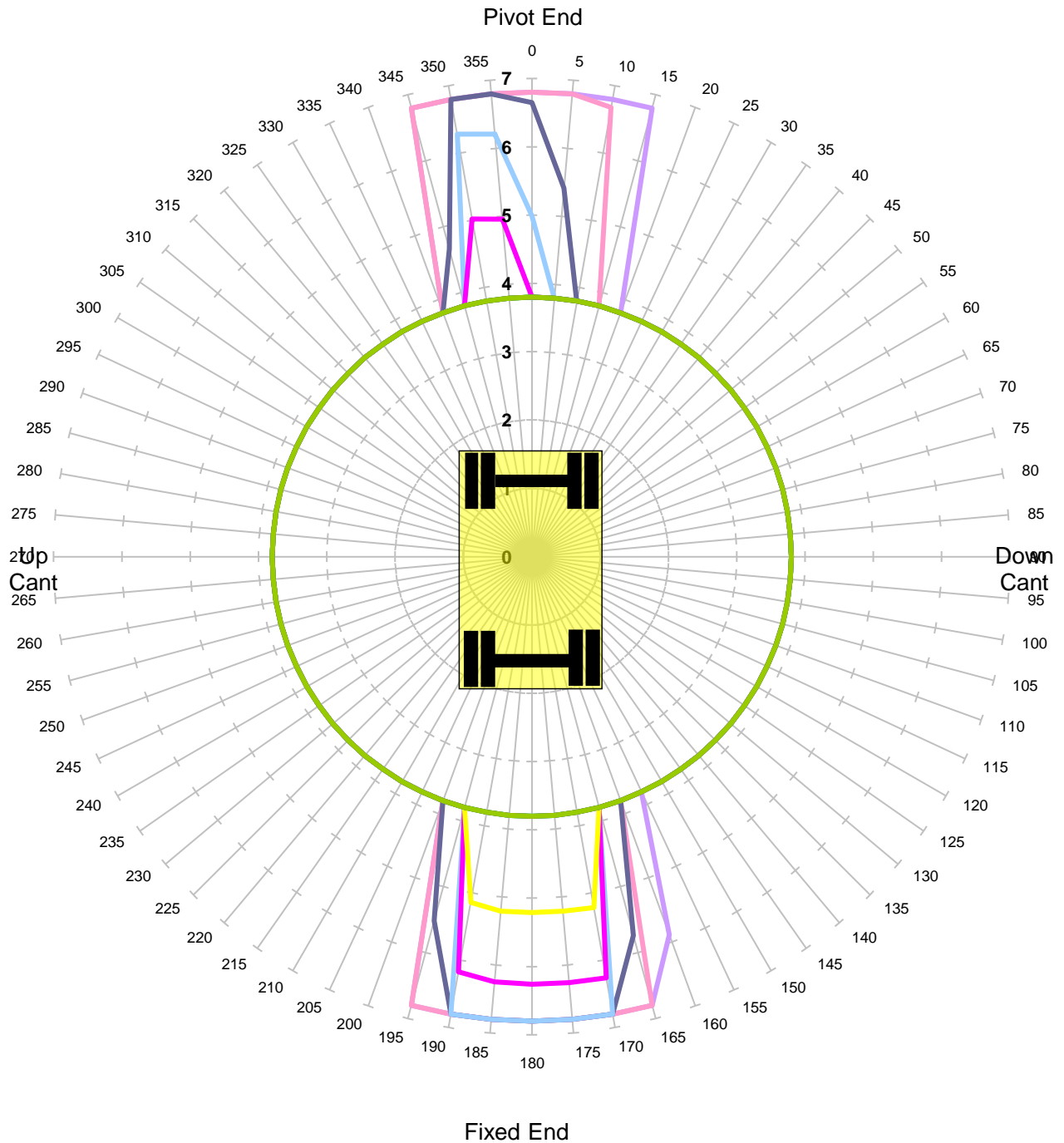

Units in Tonnes

- 1   
 — 2   
 — 3   
 — 4   
 — 5   
 — 6   
 — 7   
 — 8   
 — 9   
 — 10

<b>MACHINE &amp; MODEL:</b>	Colmar T10000FS	<b>REFERENCE:</b>	Dipper Extends by 1000mm
<b>SERIAL No:</b>	8216	<b>DATE OF CHART:</b>	20-May-2019
<b>EQUIPMENT:</b>	4.08m + 2.10m	<b>SAFETY FACTOR:</b>	45.0%
<b>COMMENT:</b>			

## Colmar T10000FS

**Max Capacity Contours of Radius(m) Plots 2.1m Dipper Cwt Out  
Gradient 1 in -25 Height 2m Lift BP**

**Unlocked Rail Cant -50mm - Tandem Lift**

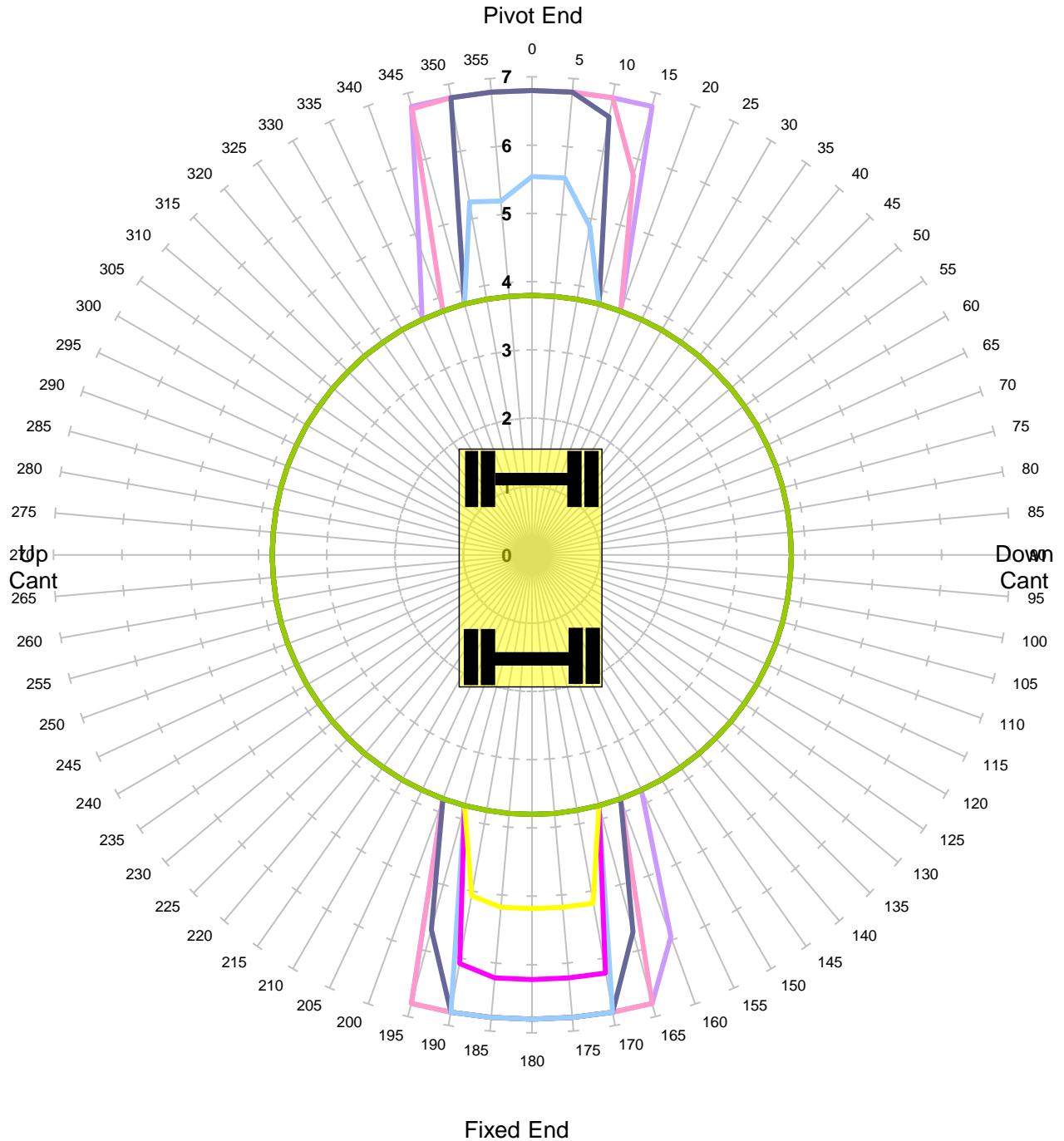

Units in Tonnes

- 1  
 — 2  
 — 3  
 — 4  
 — 5  
 — 6  
 — 7  
 — 8  
 — 9  
 — 10

<b>MACHINE &amp; MODEL:</b>	Colmar T10000FS	<b>REFERENCE:</b>	Dipper Extends by 1000mm
<b>SERIAL No:</b>	8216	<b>DATE OF CHART:</b>	20-May-2019
<b>EQUIPMENT:</b>	4.08m + 2.10m	<b>SAFETY FACTOR:</b>	45.0%
<b>COMMENT:</b>			

## Colmar T10000FS

**Max Capacity Contours of Radius(m) Plots 2.1m Dipper Cwt Out  
Gradient 1 in -25 Height 2m Lift BP**

**Unlocked Rail Cant 50mm - Tandem Lift**

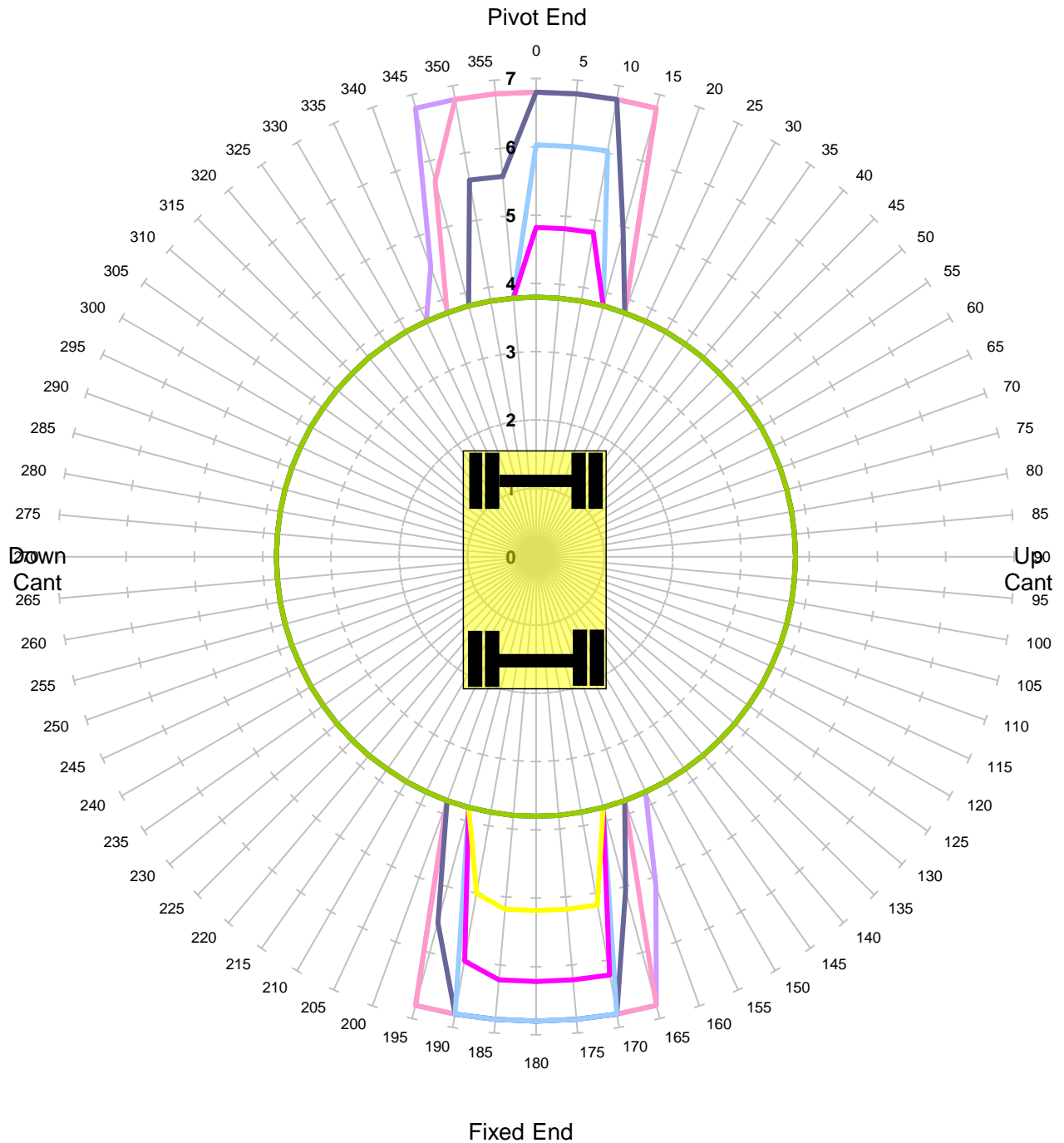

Units in Tonnes

- 1   
 — 2   
 — 3   
 — 4   
 — 5   
 — 6   
 — 7   
 — 8   
 — 9   
 — 10

<b>MACHINE &amp; MODEL:</b>	Colmar T10000FS	<b>REFERENCE:</b>	Dipper Extends by 1000mm
<b>SERIAL No:</b>	8216	<b>DATE OF CHART:</b>	20-May-2019
<b>EQUIPMENT:</b>	4.08m + 2.10m	<b>SAFETY FACTOR:</b>	45.0%
<b>COMMENT:</b>			

## Colmar T10000FS

**Max Capacity Contours of Radius(m) Plots 2.1m Dipper Cwt Out  
Gradient 1 in -25 Height 2m Lift BP**

**Unlocked Rail Cant 150mm - Tandem Lift**

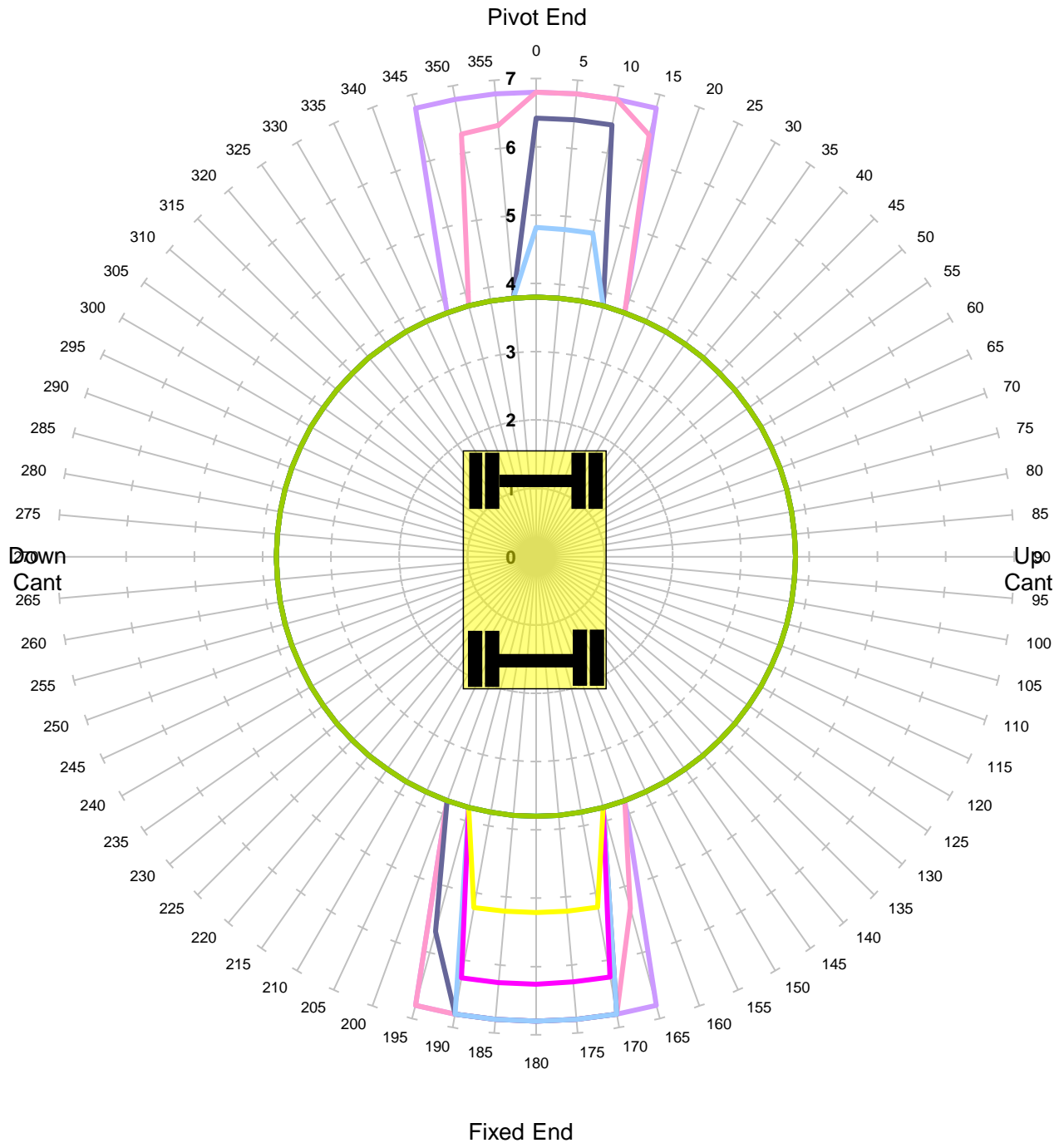

<b>MACHINE &amp; MODEL:</b>	Colmar T10000FS	<b>REFERENCE:</b>	Dipper Extends by 1000mm
<b>SERIAL No:</b>	8216	<b>DATE OF CHART:</b>	20-May-2019
<b>EQUIPMENT:</b>	4.08m + 2.10m	<b>SAFETY FACTOR:</b>	45.0%
<b>COMMENT:</b>			

## Colmar T10000FS

**Max Capacity Contours of Radius(m) Plots 2.1m Dipper Cwt Out  
Gradient 1 in -25 Height 2m Lift BP**

**Locked Rail Cant -150mm - Tandem Lift**

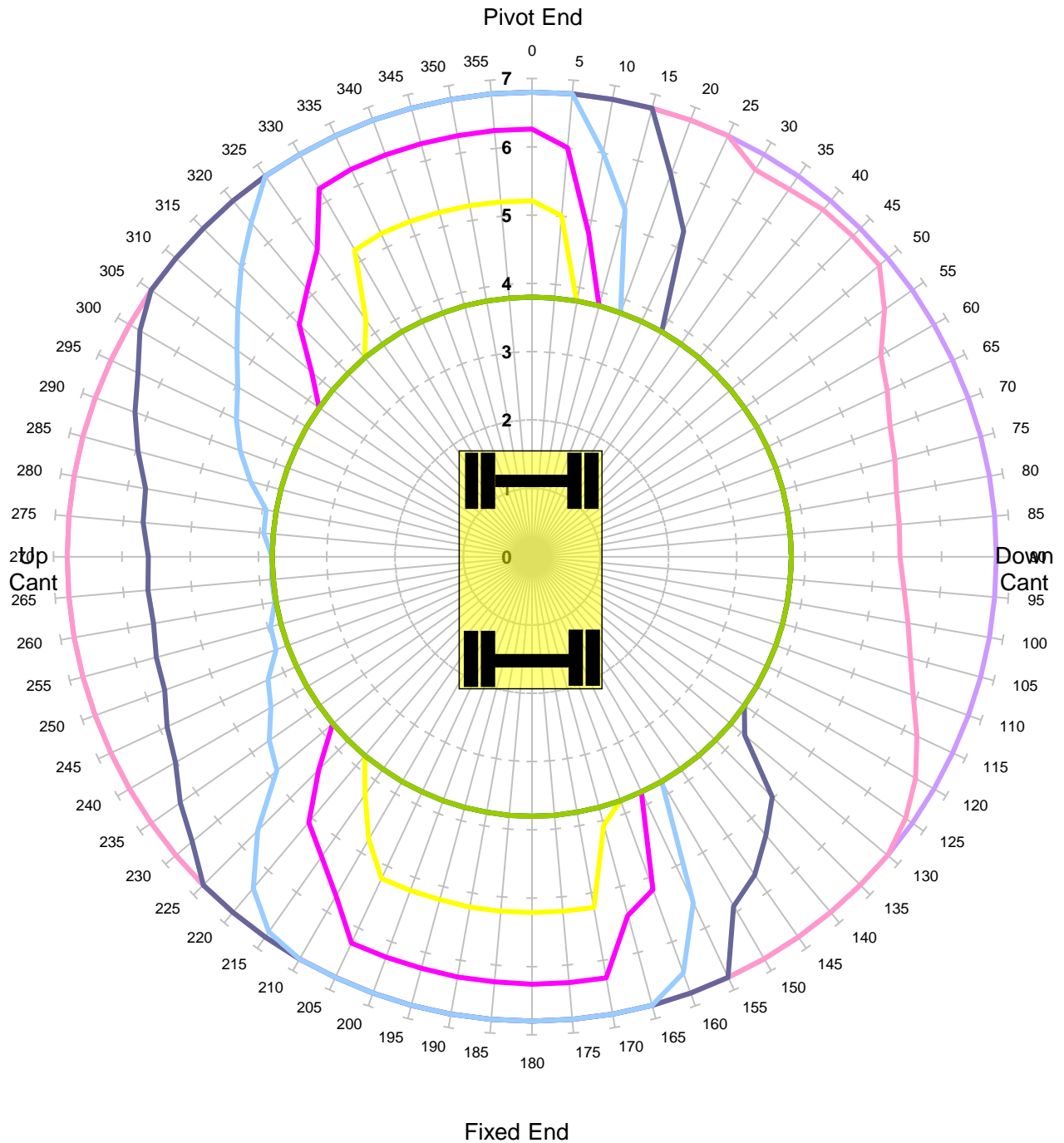

Units in Tonnes

- 1  
 — 2  
 — 3  
 — 4  
 — 5  
 — 6  
 — 7  
 — 8  
 — 9  
 — 10

<b>MACHINE &amp; MODEL:</b>	Colmar T10000FS	<b>REFERENCE:</b>	Dipper Extends by 1000mm
<b>SERIAL No:</b>	8216	<b>DATE OF CHART:</b>	20-May-2019
<b>EQUIPMENT:</b>	4.08m + 2.10m	<b>SAFETY FACTOR:</b>	60.0%
<b>COMMENT:</b>			

## Colmar T10000FS

**Max Capacity Contours of Radius(m) Plots 2.1m Dipper Cwt Out  
Gradient 1 in -25 Height 2m Lift BP**

**Locked Rail Cant -50mm - Tandem Lift**

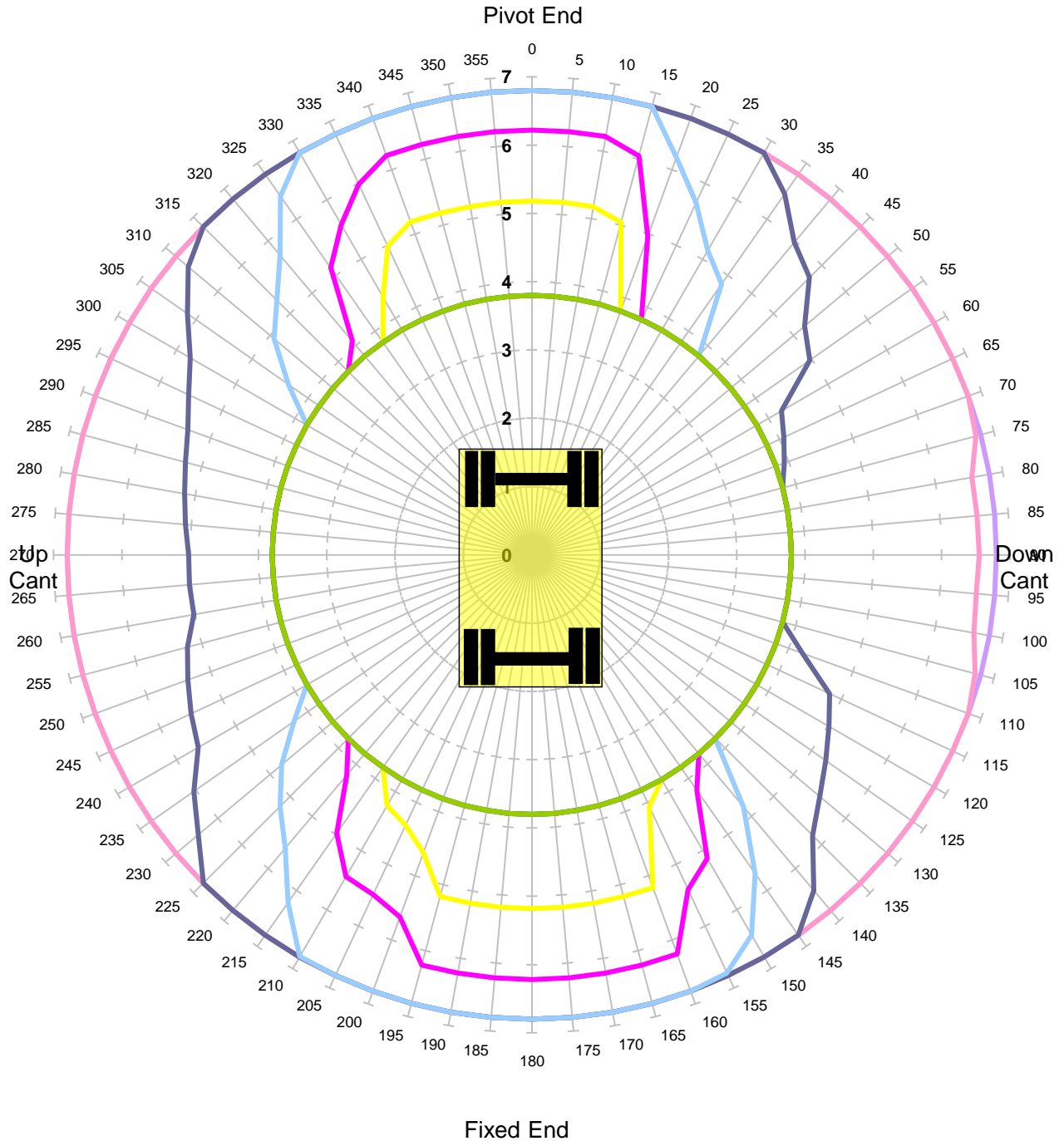

Units in Tonnes

- 1  
 — 2  
 — 3  
 — 4  
 — 5  
 — 6  
 — 7  
 — 8  
 — 9  
 — 10

<b>MACHINE &amp; MODEL:</b>	Colmar T10000FS	<b>REFERENCE:</b>	Dipper Extends by 1000mm
<b>SERIAL No:</b>	8216	<b>DATE OF CHART:</b>	20-May-2019
<b>EQUIPMENT:</b>	4.08m + 2.10m	<b>SAFETY FACTOR:</b>	60.0%
<b>COMMENT:</b>			



## Colmar T10000FS

**Max Capacity Contours of Radius(m) Plots 2.1m Dipper Cwt Out  
Gradient 1 in -25 Height 2m Lift BP**

**Locked Rail Cant 50mm - Tandem Lift**

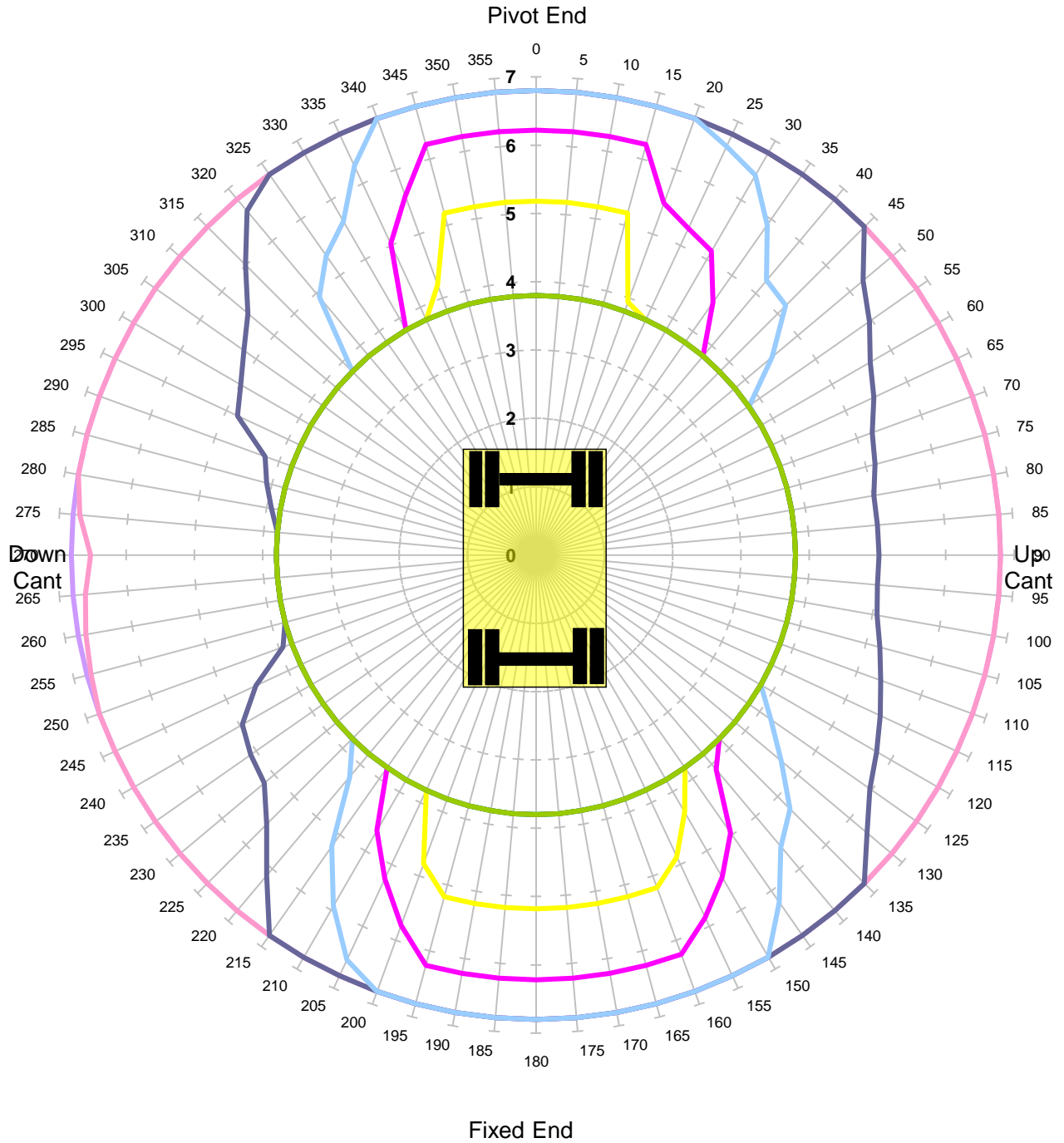

Units in Tonnes

- 1  
 — 2  
 — 3  
 — 4  
 — 5  
 — 6  
 — 7  
 — 8  
 — 9  
 — 10

<b>MACHINE &amp; MODEL:</b>	Colmar T10000FS	<b>REFERENCE:</b>	Dipper Extends by 1000mm
<b>SERIAL No:</b>	8216	<b>DATE OF CHART:</b>	20-May-2019
<b>EQUIPMENT:</b>	4.08m + 2.10m	<b>SAFETY FACTOR:</b>	60.0%
<b>COMMENT:</b>			

## Colmar T10000FS

**Max Capacity Contours of Radius(m) Plots 2.1m Dipper Cwt Out  
Gradient 1 in -25 Height 2m Lift BP**

**Locked Rail Cant 150mm - Tandem Lift**

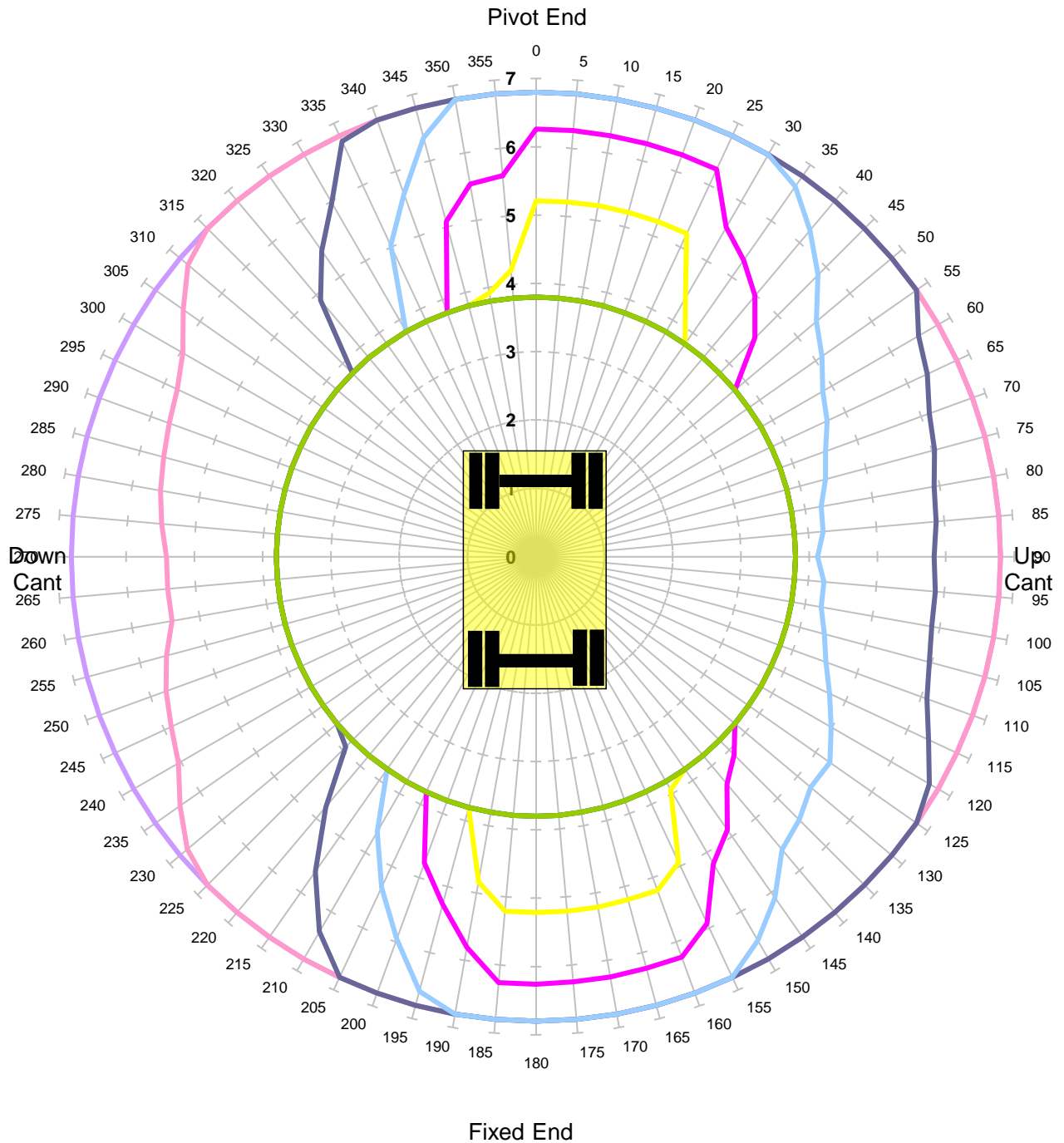

Units in Tonnes

- 1   
 — 2   
 — 3   
 — 4   
 — 5   
 — 6   
 — 7   
 — 8   
 — 9   
 — 10

<b>MACHINE &amp; MODEL:</b>	Colmar T10000FS	<b>REFERENCE:</b>	Dipper Extends by 1000mm
<b>SERIAL No:</b>	8216	<b>DATE OF CHART:</b>	20-May-2019
<b>EQUIPMENT:</b>	4.08m + 2.10m	<b>SAFETY FACTOR:</b>	60.0%
<b>COMMENT:</b>			

**Colmar T10000FS**  
**Max Capacity Contours of Radius(m) Plots 2.1m Dipper Cwt Out**  
**Level Ground Height 2m Lift BP**  
**Unlocked Road - Tandem Lift**

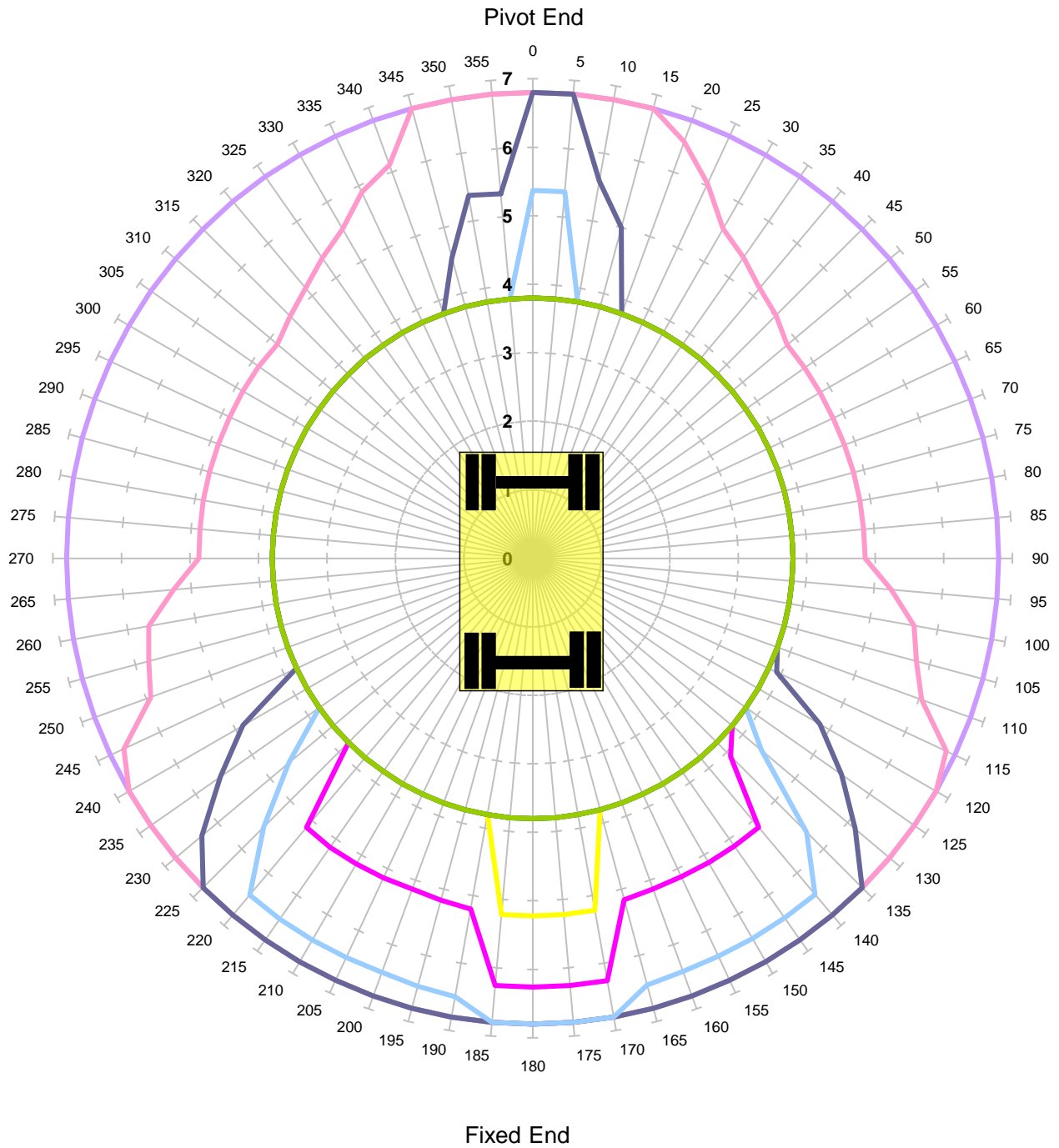

Units in Tonnes

- 1   
 — 2   
 — 3   
 — 4   
 — 5   
 — 6   
 — 7   
 — 8   
 — 9   
 — 10

<b>MACHINE &amp; MODEL:</b>	Colmar T10000FS	<b>REFERENCE:</b>	Dipper Extends by 1000mm
<b>SERIAL No:</b>	8216	<b>DATE OF CHART:</b>	20-May-2019
<b>EQUIPMENT:</b>	4.08m + 2.10m	<b>SAFETY FACTOR:</b>	47.0%
<b>COMMENT:</b>			

**Colmar T10000FS**  
**Max Capacity Contours of Radius(m) Plots 2.1m Dipper Cwt Out**  
**Level Ground Height 2m Lift BP**  
**Locked Road - Tandem Lift**

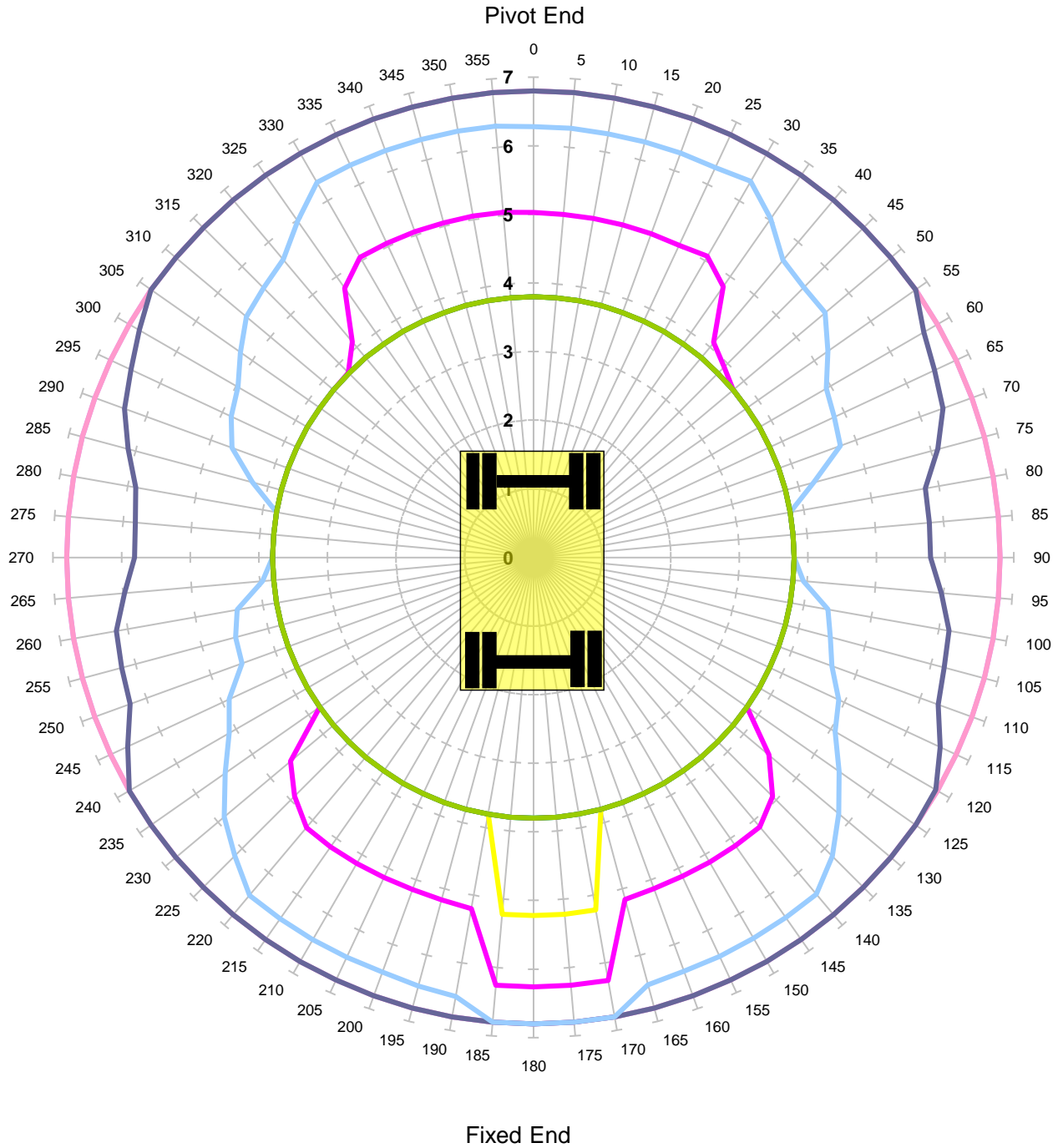

Units in Tonnes

- 1
- 2
- 3
- 4
- 5
- 6
- 7
- 8
- 9
- 10

<b>MACHINE &amp; MODEL:</b>	Colmar T10000FS	<b>REFERENCE:</b>	Dipper Extends by 1000mm
<b>SERIAL No:</b>	8216	<b>DATE OF CHART:</b>	20-May-2019
<b>EQUIPMENT:</b>	4.08m + 2.10m	<b>SAFETY FACTOR:</b>	47.0%
<b>COMMENT:</b>			

**Colmar T10000FS**  
**Max Capacity Contours of Radius(m) Plots 3.1m Dipper Cwt Out**  
**Gradient 1 in -25 Height 2m Lift BP**  
**Unlocked Rail Cant -150mm**

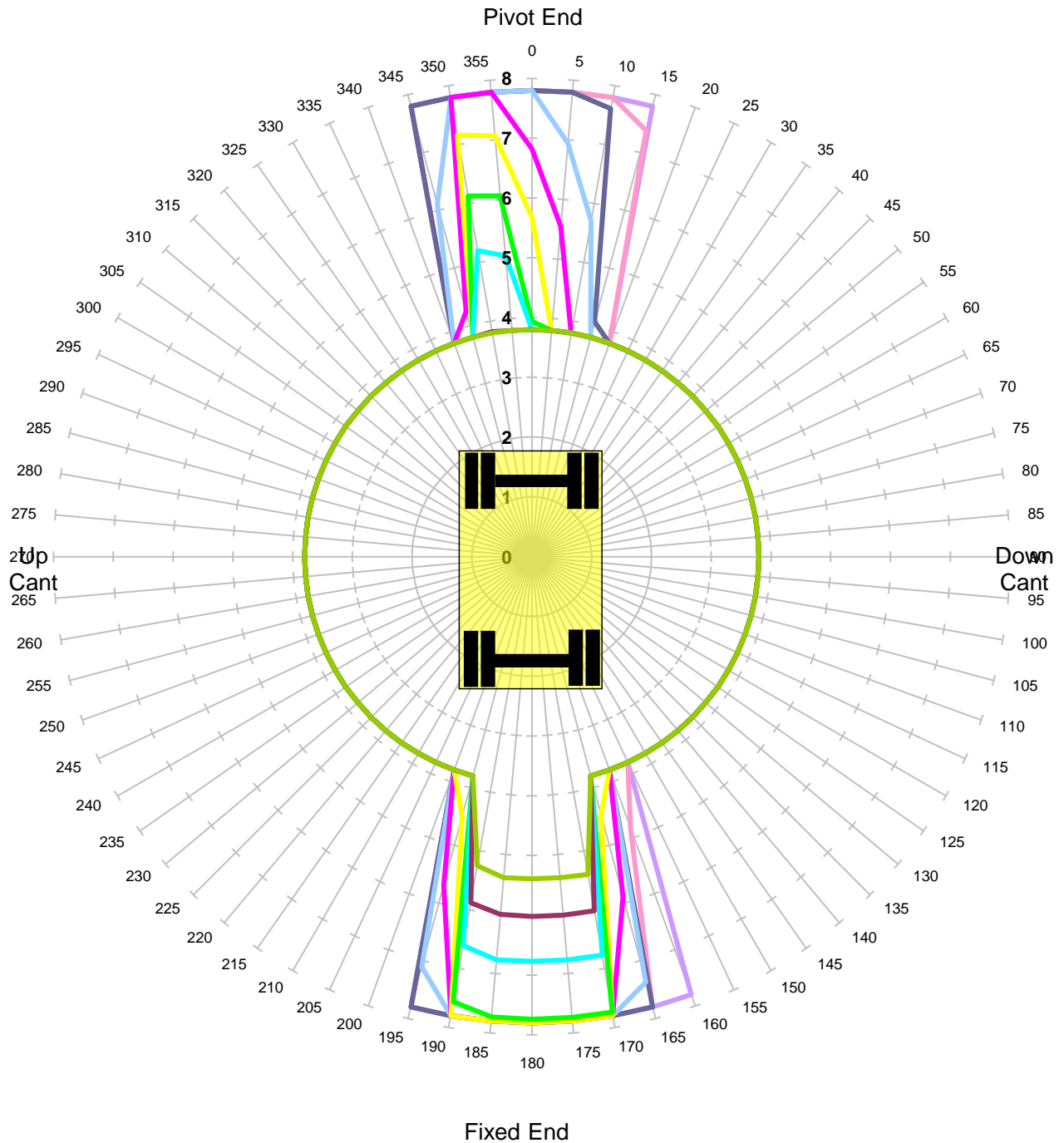

<b>MACHINE &amp; MODEL:</b>	Colmar T10000FS	<b>REFERENCE:</b>	Dipper Extends by 1000mm
<b>SERIAL No:</b>	8216	<b>DATE OF CHART:</b>	20-May-2019
<b>EQUIPMENT:</b>	4.08m + 2.10m	<b>SAFETY FACTOR:</b>	67.0%
<b>COMMENT:</b>			

**Colmar T10000FS**  
**Max Capacity Contours of Radius(m) Plots 3.1m Dipper Cwt Out**  
**Gradient 1 in -25 Height 2m Lift BP**  
**Unlocked Rail Cant -50mm**

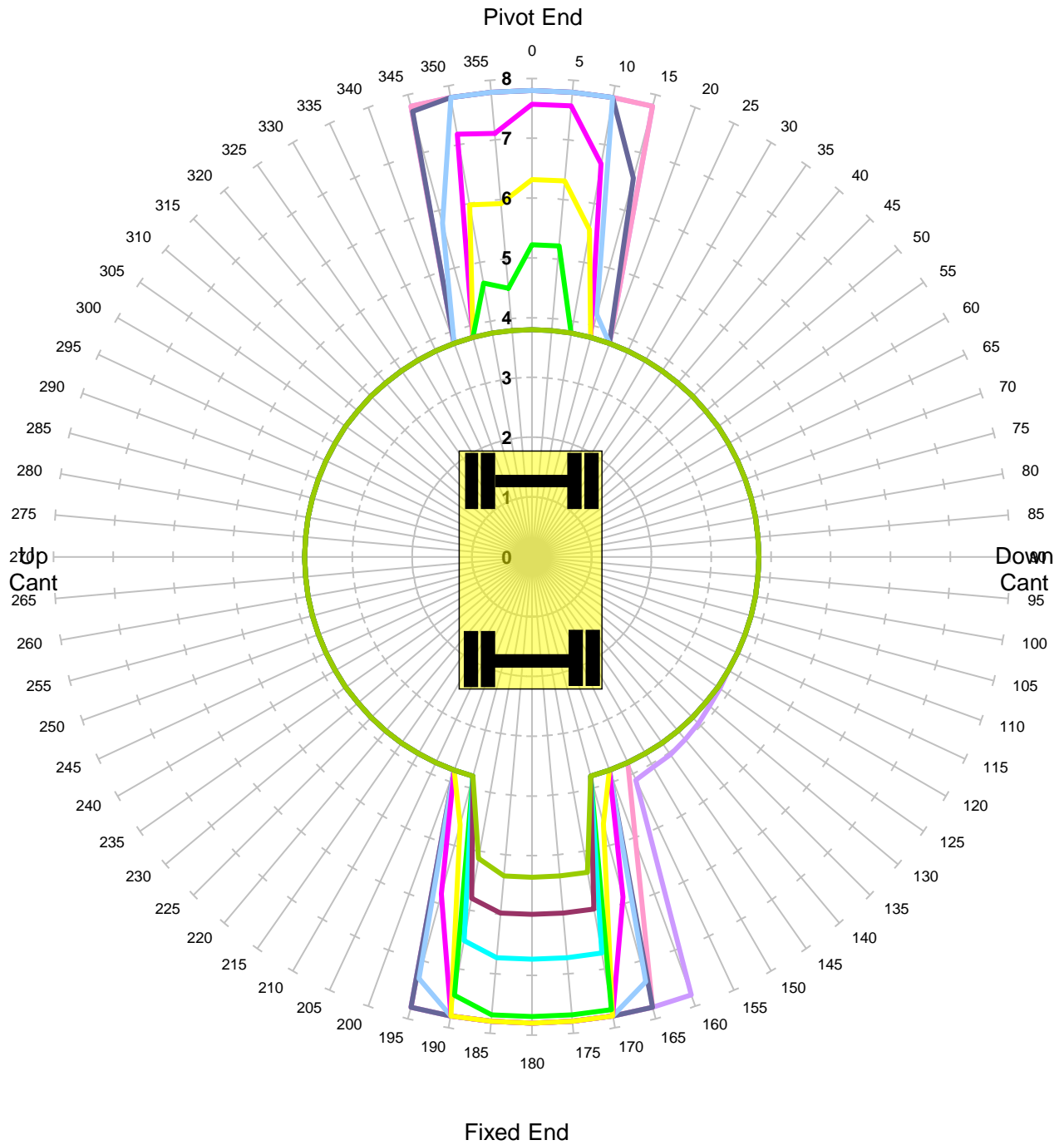

Units in Tonnes

- 1
- 2
- 3
- 4
- 5
- 6
- 7
- 8
- 9
- 10

<b>MACHINE &amp; MODEL:</b>	Colmar T10000FS	<b>REFERENCE:</b>	Dipper Extends by 1000mm
<b>SERIAL No:</b>	8216	<b>DATE OF CHART:</b>	20-May-2019
<b>EQUIPMENT:</b>	4.08m + 2.10m	<b>SAFETY FACTOR:</b>	67.0%
<b>COMMENT:</b>			



**Colmar T10000FS**  
**Max Capacity Contours of Radius(m) Plots 3.1m Dipper Cwt Out**  
**Gradient 1 in -25 Height 2m Lift BP**  
**Unlocked Rail Cant 50mm**

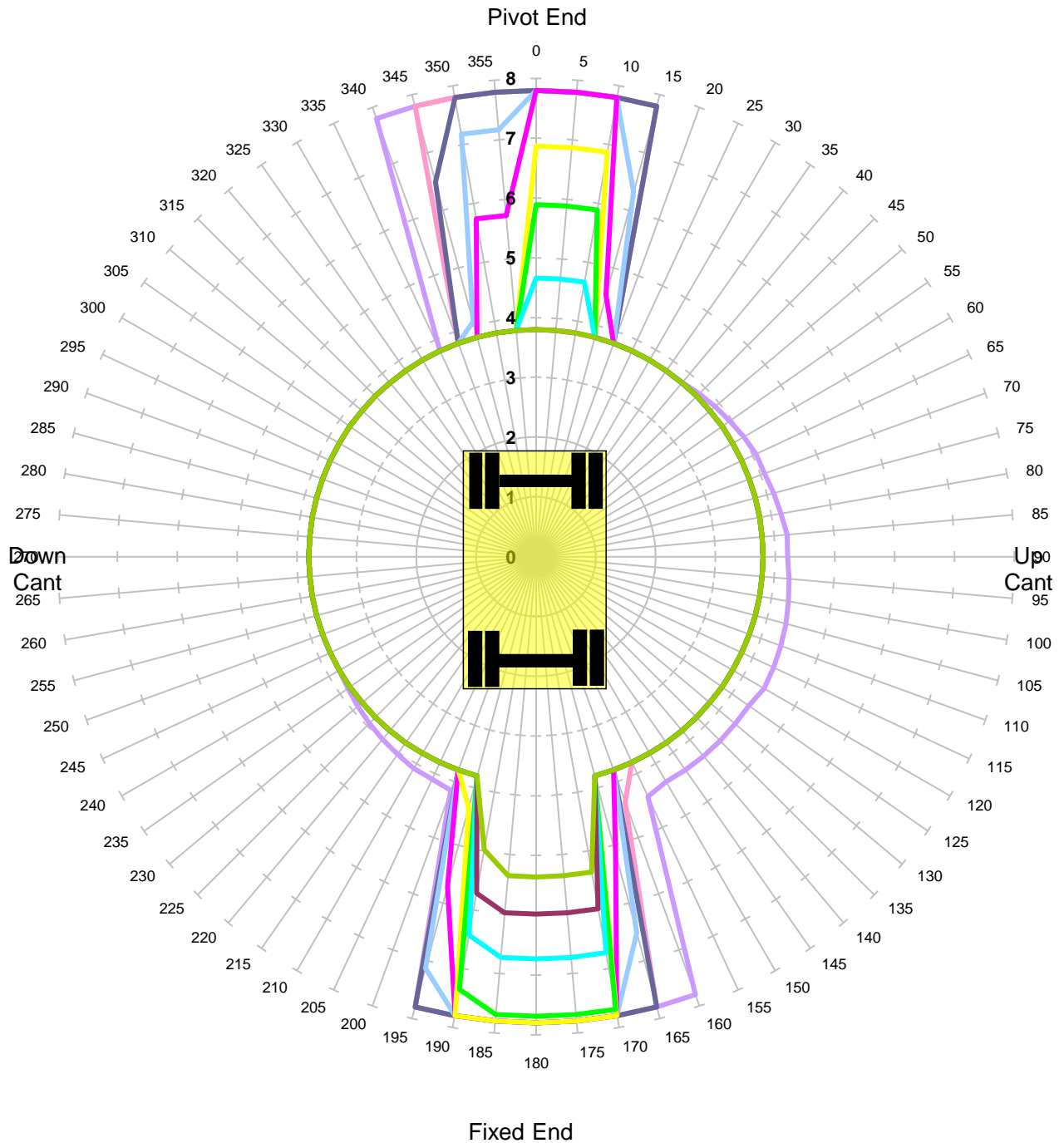

Units in Tonnes

- 1
- 2
- 3
- 4
- 5
- 6
- 7
- 8
- 9
- 10

<b>MACHINE &amp; MODEL:</b>	Colmar T10000FS	<b>REFERENCE:</b>	Dipper Extends by 1000mm
<b>SERIAL No:</b>	8216	<b>DATE OF CHART:</b>	20-May-2019
<b>EQUIPMENT:</b>	4.08m + 2.10m	<b>SAFETY FACTOR:</b>	67.0%
<b>COMMENT:</b>			

**Colmar T10000FS**  
**Max Capacity Contours of Radius(m) Plots 3.1m Dipper Cwt Out**  
**Gradient 1 in -25 Height 2m Lift BP**  
**Unlocked Rail Cant 150mm**

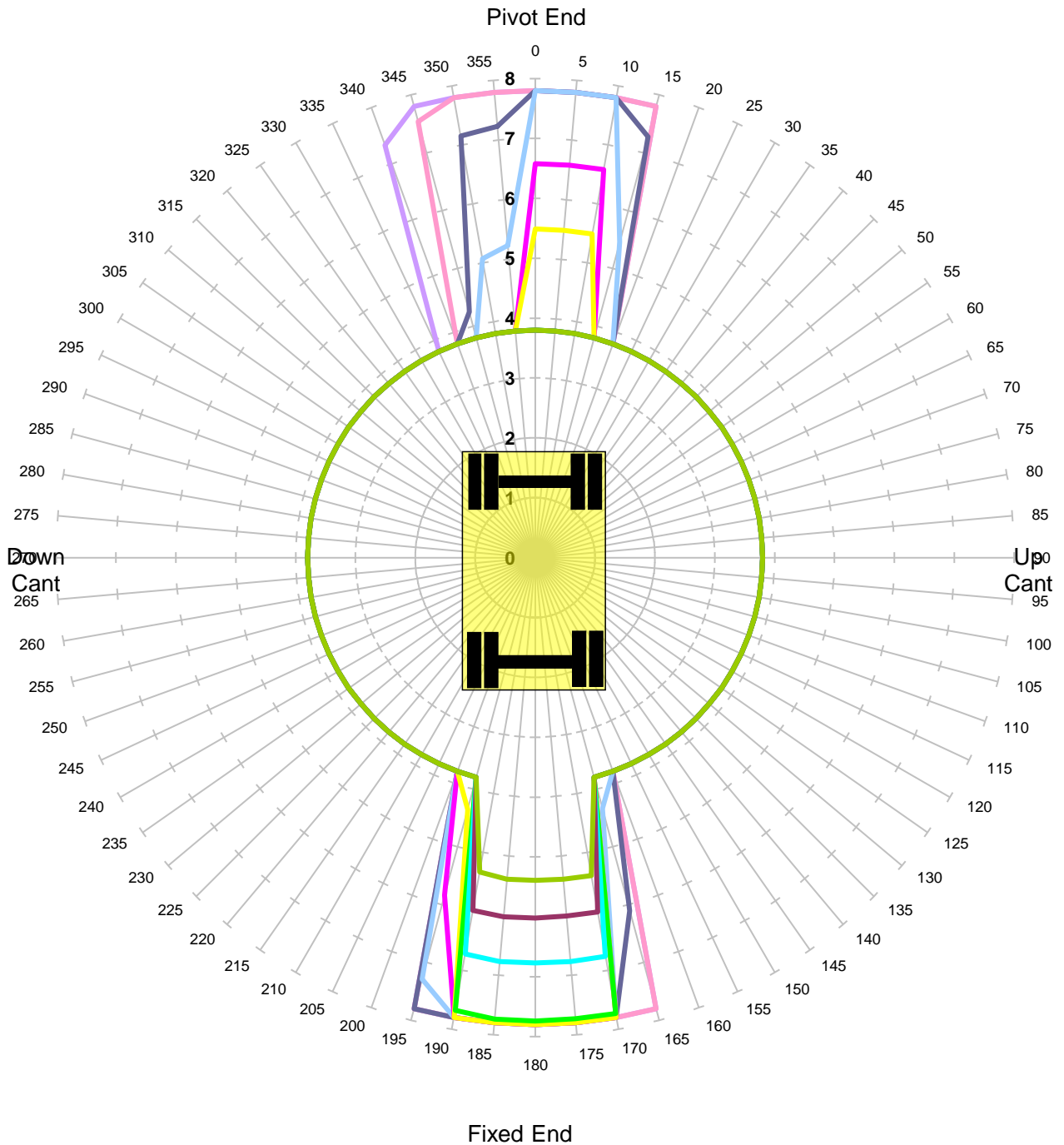

Units in Tonnes

- 1
- 2
- 3
- 4
- 5
- 6
- 7
- 8
- 9
- 10

<b>MACHINE &amp; MODEL:</b>	Colmar T10000FS	<b>REFERENCE:</b>	Dipper Extends by 1000mm
<b>SERIAL No:</b>	8216	<b>DATE OF CHART:</b>	20-May-2019
<b>EQUIPMENT:</b>	4.08m + 2.10m	<b>SAFETY FACTOR:</b>	67.0%
<b>COMMENT:</b>			

**Colmar T10000FS**  
**Max Capacity Contours of Radius(m) Plots 3.1m Dipper Cwt Out**  
**Gradient 1 in -25 Height 2m Lift BP**  
**Locked Rail Cant -150mm**

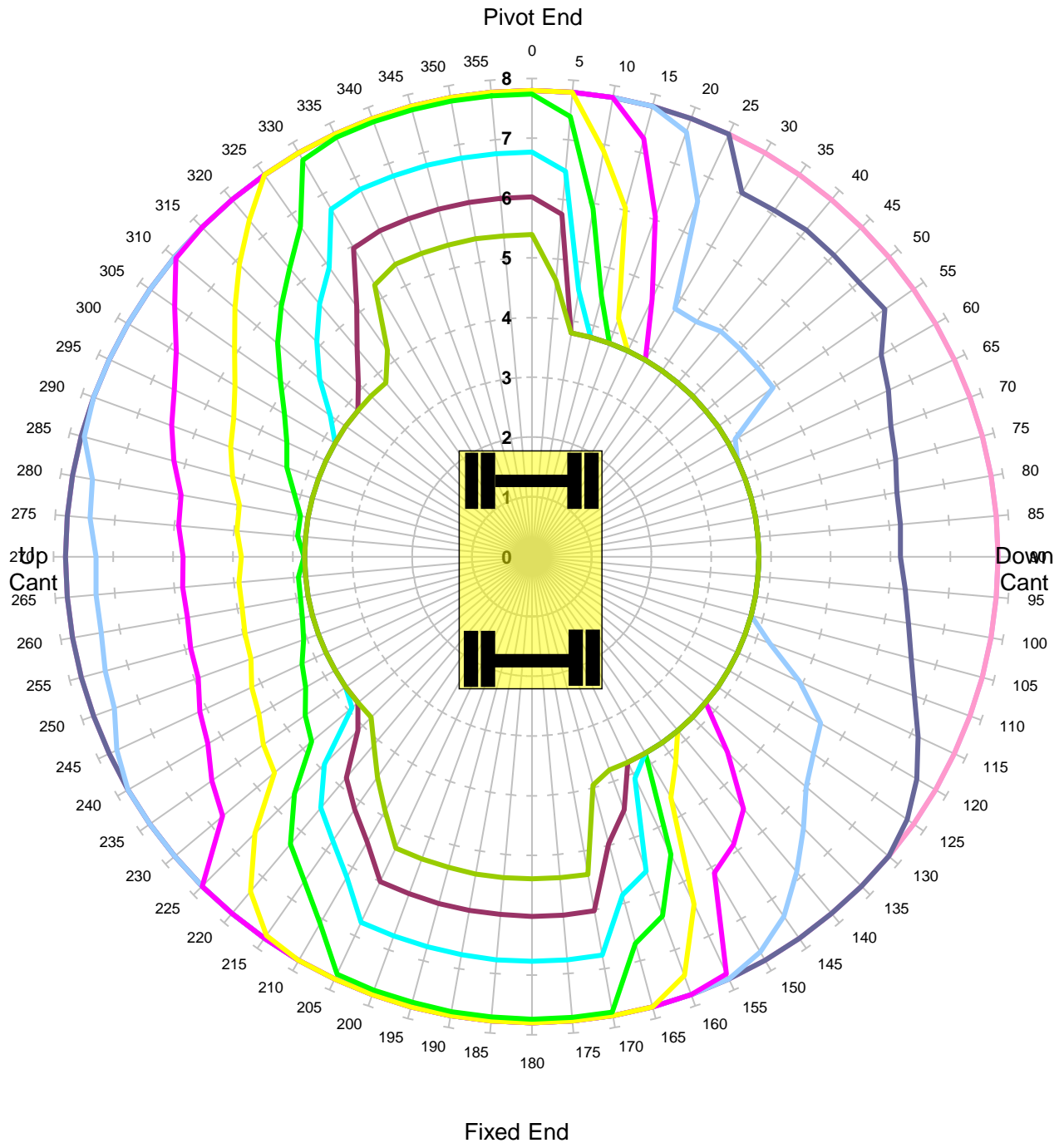

<b>MACHINE &amp; MODEL:</b>	Colmar T10000FS	<b>REFERENCE:</b>	Dipper Extends by 1000mm
<b>SERIAL No:</b>	8216	<b>DATE OF CHART:</b>	20-May-2019
<b>EQUIPMENT:</b>	4.08m + 2.10m	<b>SAFETY FACTOR:</b>	90.0%
<b>COMMENT:</b>			

**Colmar T10000FS**  
**Max Capacity Contours of Radius(m) Plots 3.1m Dipper Cwt Out**  
**Gradient 1 in -25 Height 2m Lift BP**  
**Locked Rail Cant -50mm**

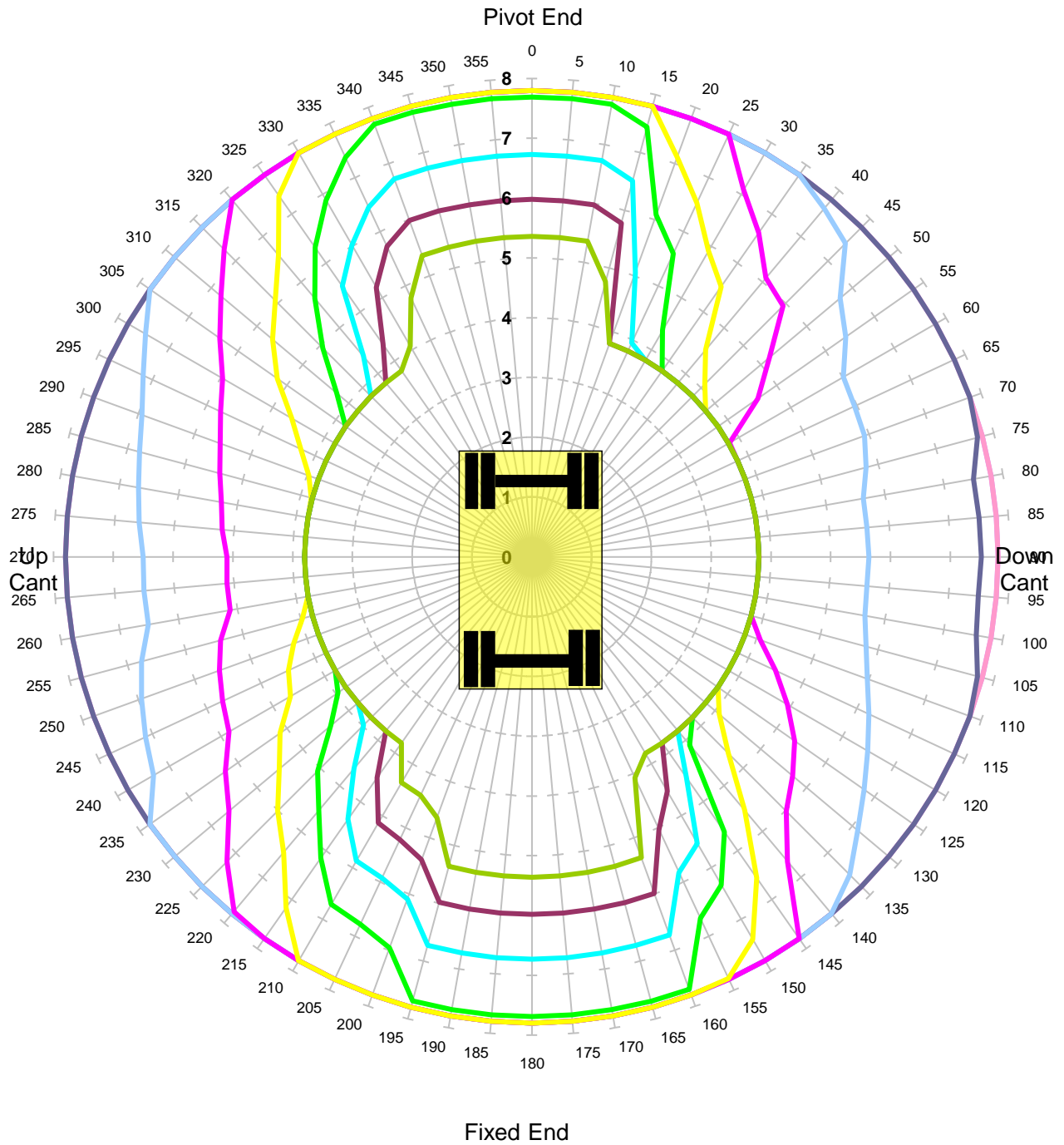

Units in Tonnes

- 1
- 2
- 3
- 4
- 5
- 6
- 7
- 8
- 9
- 10

<b>MACHINE &amp; MODEL:</b>	Colmar T10000FS	<b>REFERENCE:</b>	Dipper Extends by 1000mm
<b>SERIAL No:</b>	8216	<b>DATE OF CHART:</b>	20-May-2019
<b>EQUIPMENT:</b>	4.08m + 2.10m	<b>SAFETY FACTOR:</b>	90.0%
<b>COMMENT:</b>			

**Colmar T10000FS**  
**Max Capacity Contours of Radius(m) Plots 3.1m Dipper Cwt Out**  
**Gradient 1 in -25 Height 2m Lift BP**  
**Locked Rail Cant 50mm**

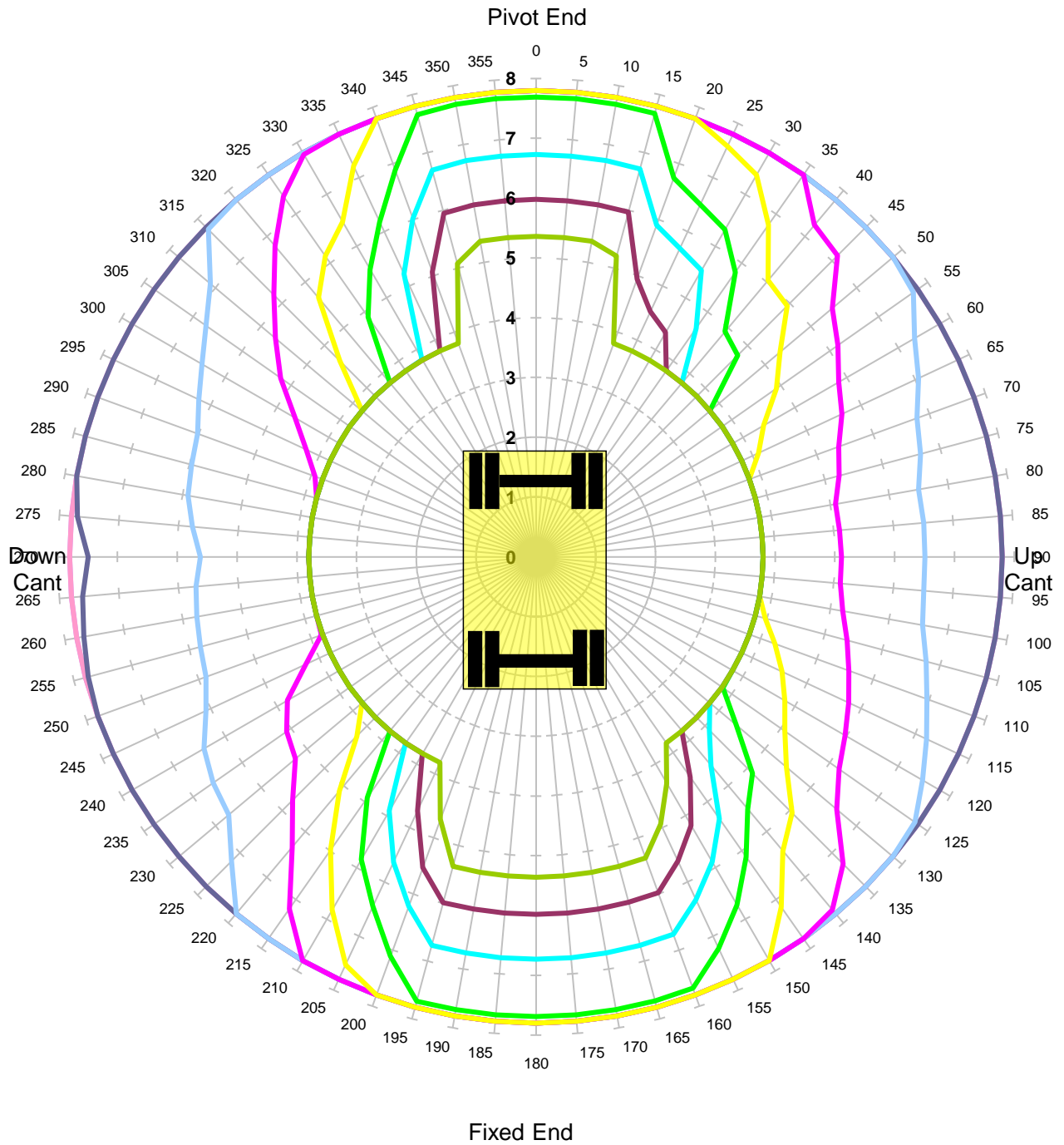

Units in Tonnes  
 1 2 3 4 5 6 7 8 9 10

<b>MACHINE &amp; MODEL:</b>	Colmar T10000FS	<b>REFERENCE:</b>	Dipper Extends by 1000mm
<b>SERIAL No:</b>	8216	<b>DATE OF CHART:</b>	20-May-2019
<b>EQUIPMENT:</b>	4.08m + 2.10m	<b>SAFETY FACTOR:</b>	90.0%
<b>COMMENT:</b>			

**Colmar T10000FS**  
**Max Capacity Contours of Radius(m) Plots 3.1m Dipper Cwt Out**  
**Gradient 1 in -25 Height 2m Lift BP**  
**Locked Rail Cant 150mm**

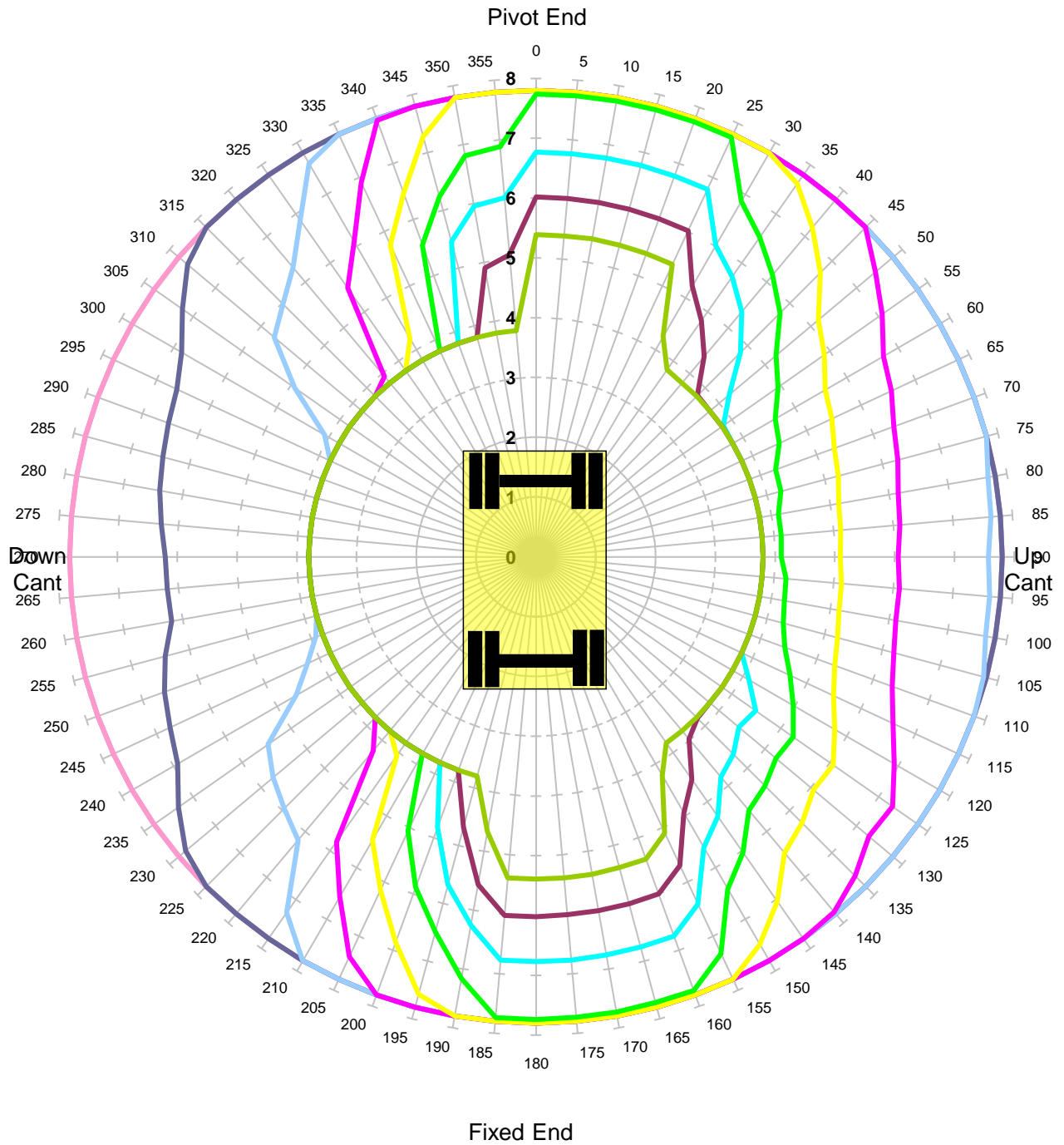

Units in Tonnes

- 1
- 2
- 3
- 4
- 5
- 6
- 7
- 8
- 9
- 10

<b>MACHINE &amp; MODEL:</b>	Colmar T10000FS	<b>REFERENCE:</b>	Dipper Extends by 1000mm
<b>SERIAL No:</b>	8216	<b>DATE OF CHART:</b>	20-May-2019
<b>EQUIPMENT:</b>	4.08m + 2.10m	<b>SAFETY FACTOR:</b>	90.0%
<b>COMMENT:</b>			



**Colmar T10000FS**  
**Max Capacity Contours of Radius(m) Plots 3.1m Dipper Cwt Out**  
**Level Ground Height 2m Lift BP**  
**Unlocked Road**

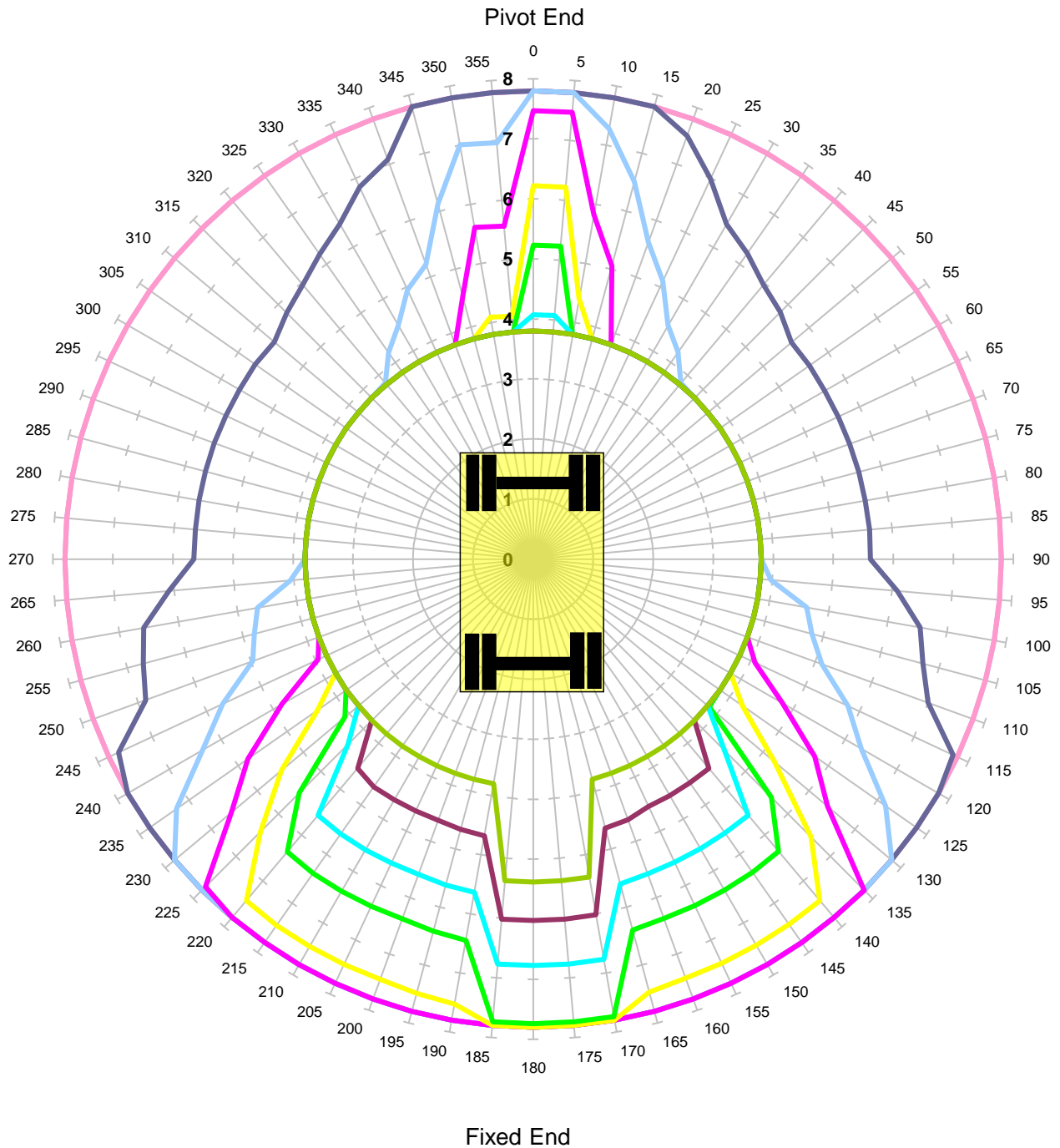

Units in Tonnes

- 1
- 2
- 3
- 4
- 5
- 6
- 7
- 8
- 9
- 10

<b>MACHINE &amp; MODEL:</b>	Colmar T10000FS	<b>REFERENCE:</b>	Dipper Extends by 1000mm
<b>SERIAL No:</b>	8216	<b>DATE OF CHART:</b>	20-May-2019
<b>EQUIPMENT:</b>	4.08m + 2.10m	<b>SAFETY FACTOR:</b>	71.0%
<b>COMMENT:</b>			

**Colmar T10000FS**  
**Max Capacity Contours of Radius(m) Plots 3.1m Dipper Cwt Out**  
**Level Ground Height 2m Lift BP**  
**Locked Road**

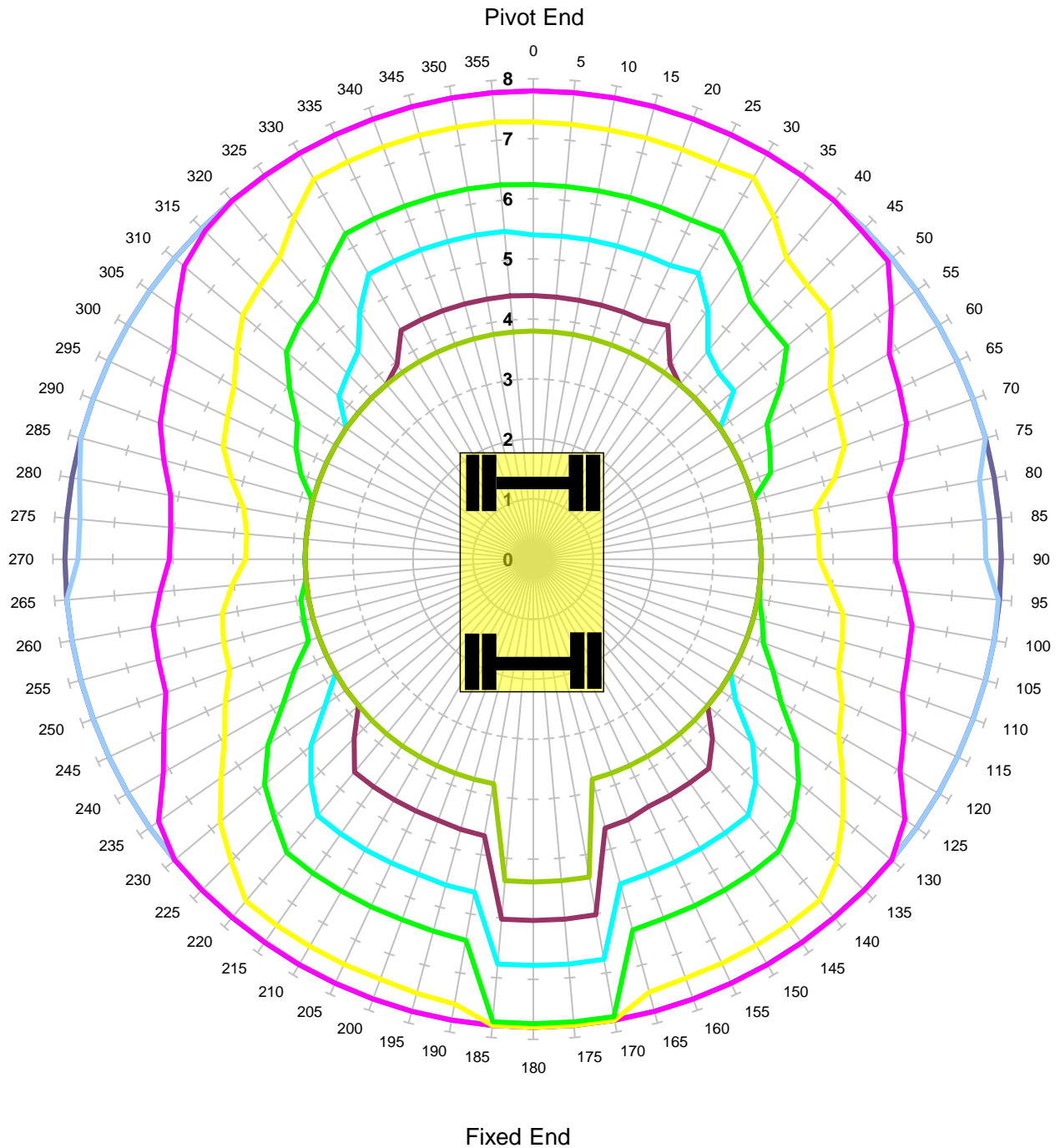

Units in Tonnes

- 1
- 2
- 3
- 4
- 5
- 6
- 7
- 8
- 9
- 10

<b>MACHINE &amp; MODEL:</b>	Colmar T10000FS	<b>REFERENCE:</b>	Dipper Extends by 1000mm
<b>SERIAL No:</b>	8216	<b>DATE OF CHART:</b>	20-May-2019
<b>EQUIPMENT:</b>	4.08m + 2.10m	<b>SAFETY FACTOR:</b>	71.0%
<b>COMMENT:</b>			

## Colmar T10000FS

**Max Capacity Contours of Radius(m) Plots 3.1m Dipper Cwt Out  
Gradient 1 in -25 Height 2m Lift BP**

**Unlocked Rail Cant -150mm - Tandem Lift**

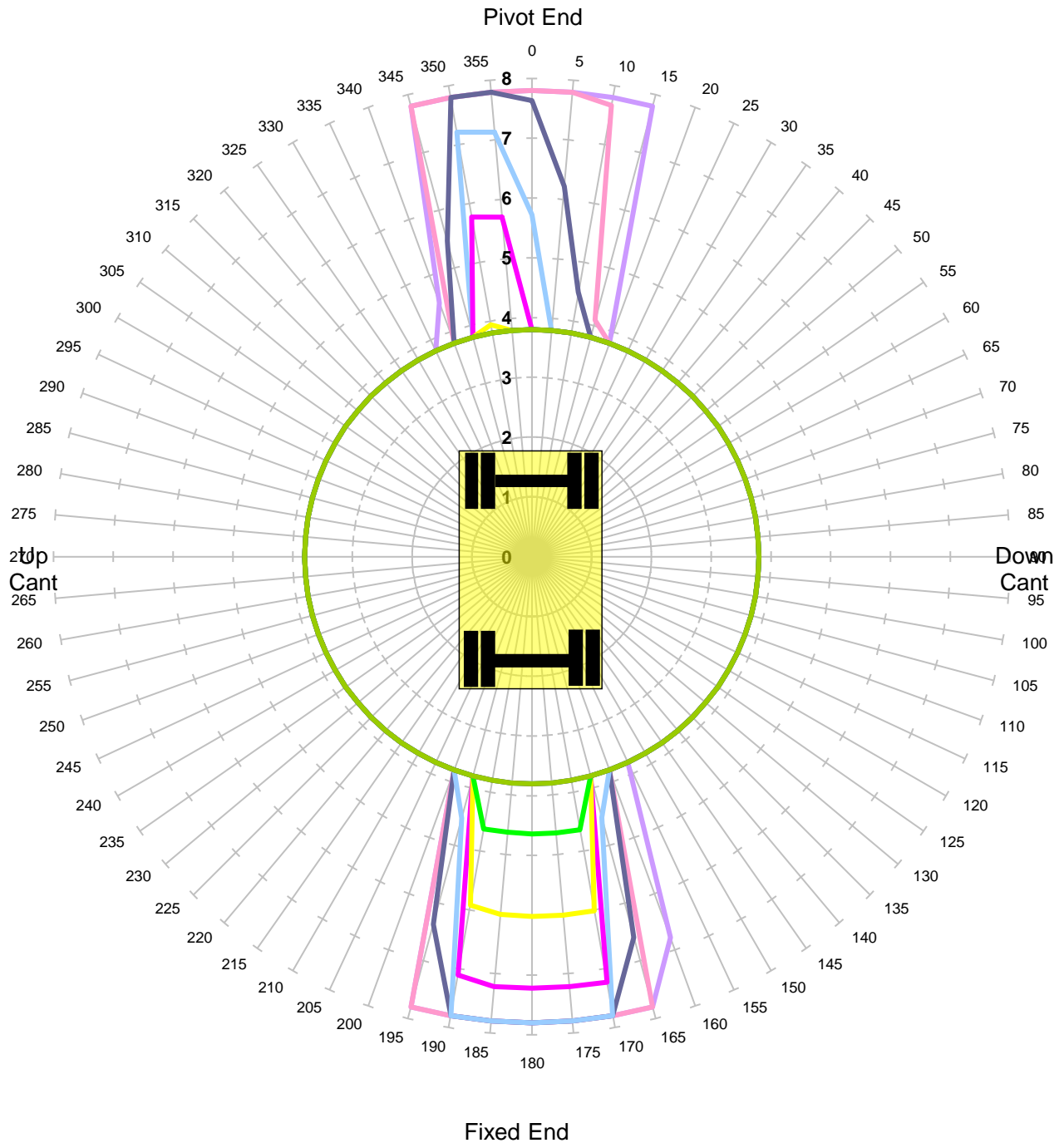

<b>MACHINE &amp; MODEL:</b>	Colmar T10000FS	<b>REFERENCE:</b>	Dipper Extends by 1000mm
<b>SERIAL No:</b>	8216	<b>DATE OF CHART:</b>	20-May-2019
<b>EQUIPMENT:</b>	4.08m + 2.10m	<b>SAFETY FACTOR:</b>	45.0%
<b>COMMENT:</b>			

## Colmar T10000FS

**Max Capacity Contours of Radius(m) Plots 3.1m Dipper Cwt Out  
Gradient 1 in -25 Height 2m Lift BP**

**Unlocked Rail Cant -50mm - Tandem Lift**

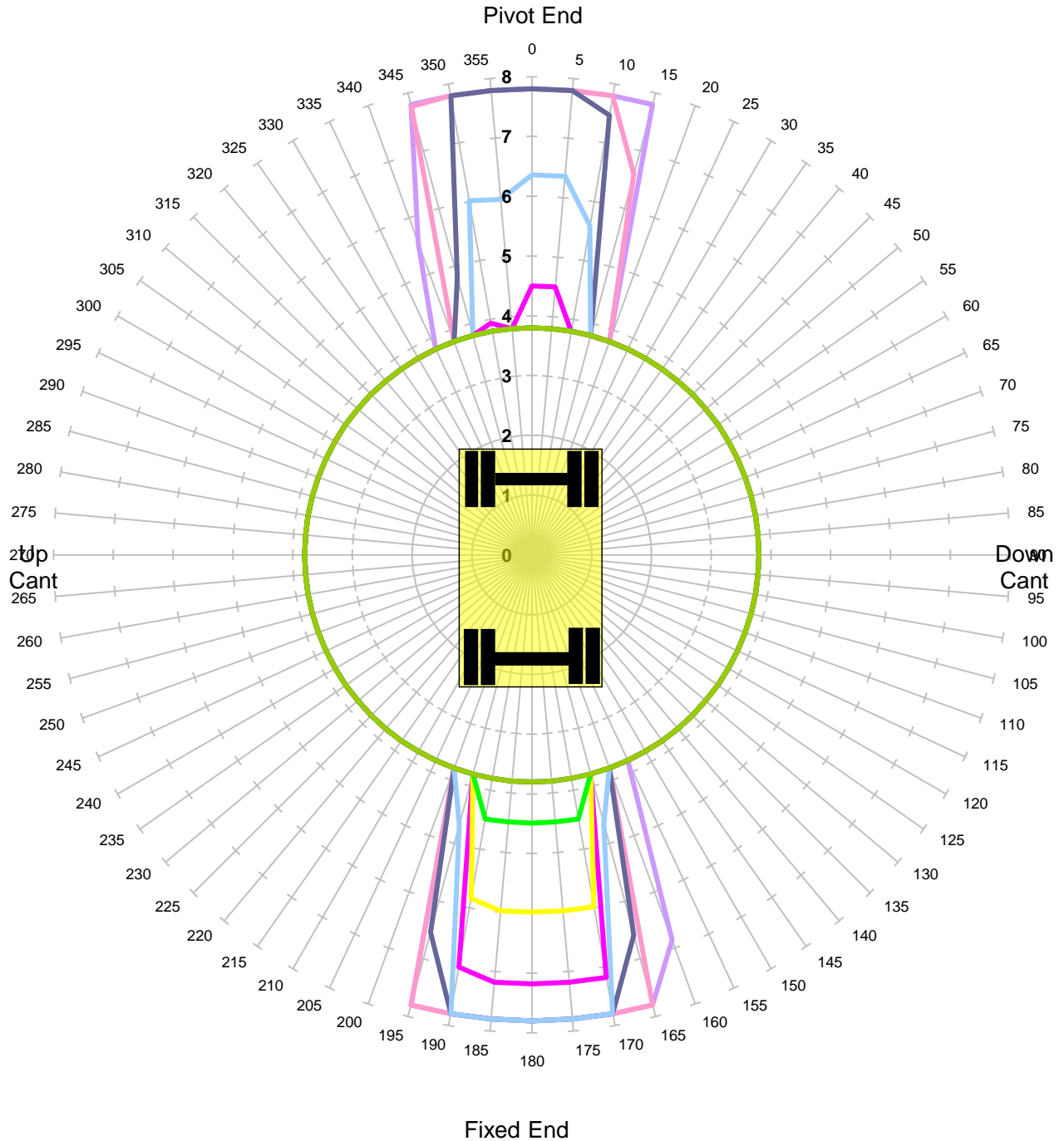

Units in Tonnes

— 1   
 — 2   
 — 3   
 — 4   
 — 5   
 — 6   
 — 7   
 — 8   
 — 9   
 — 10

<b>MACHINE &amp; MODEL:</b>	Colmar T10000FS	<b>REFERENCE:</b>	Dipper Extends by 1000mm
<b>SERIAL No:</b>	8216	<b>DATE OF CHART:</b>	20-May-2019
<b>EQUIPMENT:</b>	4.08m + 2.10m	<b>SAFETY FACTOR:</b>	45.0%
<b>COMMENT:</b>			

## Colmar T10000FS

**Max Capacity Contours of Radius(m) Plots 3.1m Dipper Cwt Out  
Gradient 1 in -25 Height 2m Lift BP**

**Unlocked Rail Cant 50mm - Tandem Lift**

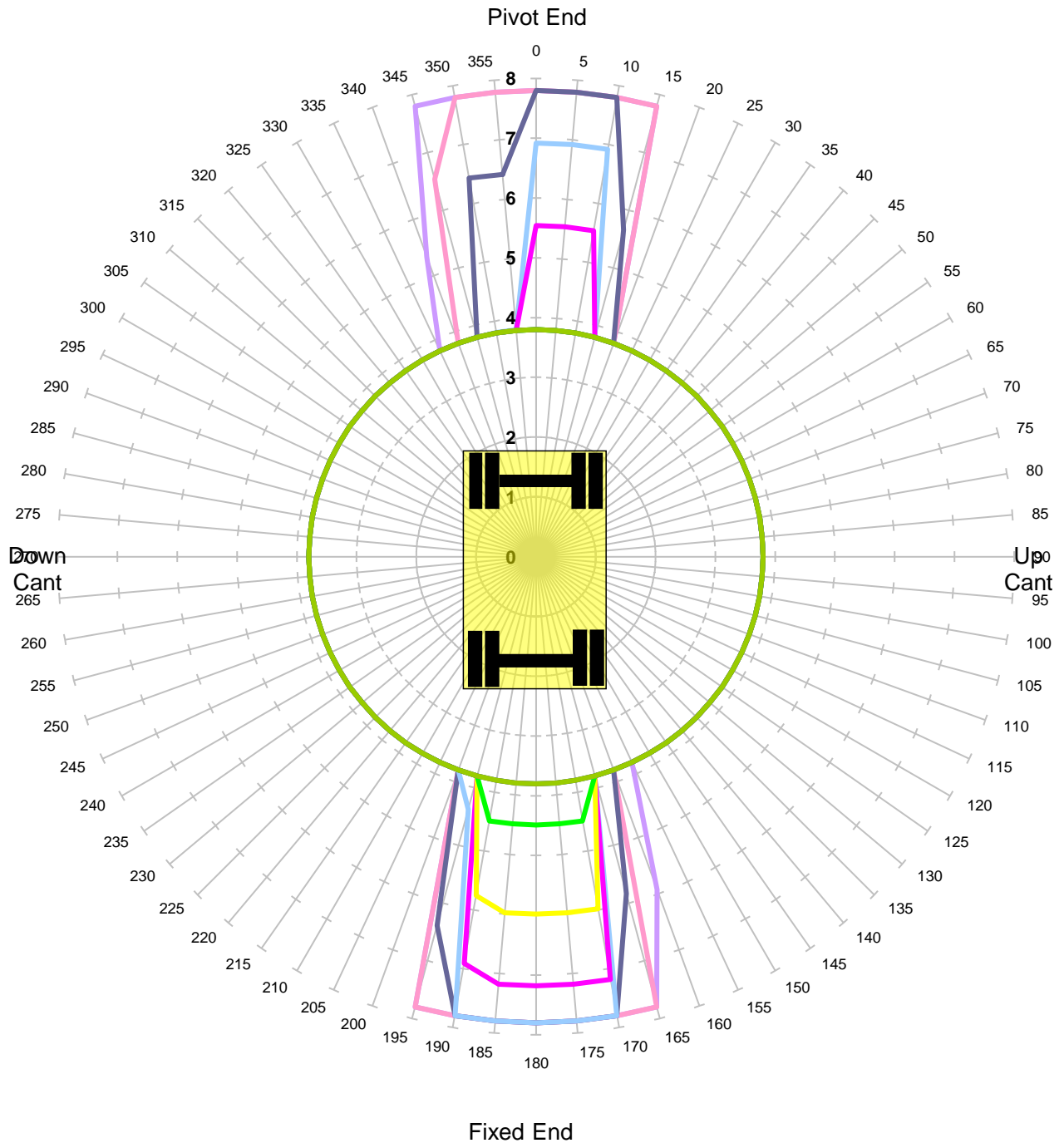

Units in Tonnes

- 1  
 — 2  
 — 3  
 — 4  
 — 5  
 — 6  
 — 7  
 — 8  
 — 9  
 — 10

<b>MACHINE &amp; MODEL:</b>	Colmar T10000FS	<b>REFERENCE:</b>	Dipper Extends by 1000mm
<b>SERIAL No:</b>	8216	<b>DATE OF CHART:</b>	20-May-2019
<b>EQUIPMENT:</b>	4.08m + 2.10m	<b>SAFETY FACTOR:</b>	45.0%
<b>COMMENT:</b>			

## Colmar T10000FS

**Max Capacity Contours of Radius(m) Plots 3.1m Dipper Cwt Out  
Gradient 1 in -25 Height 2m Lift BP**

**Unlocked Rail Cant 150mm - Tandem Lift**

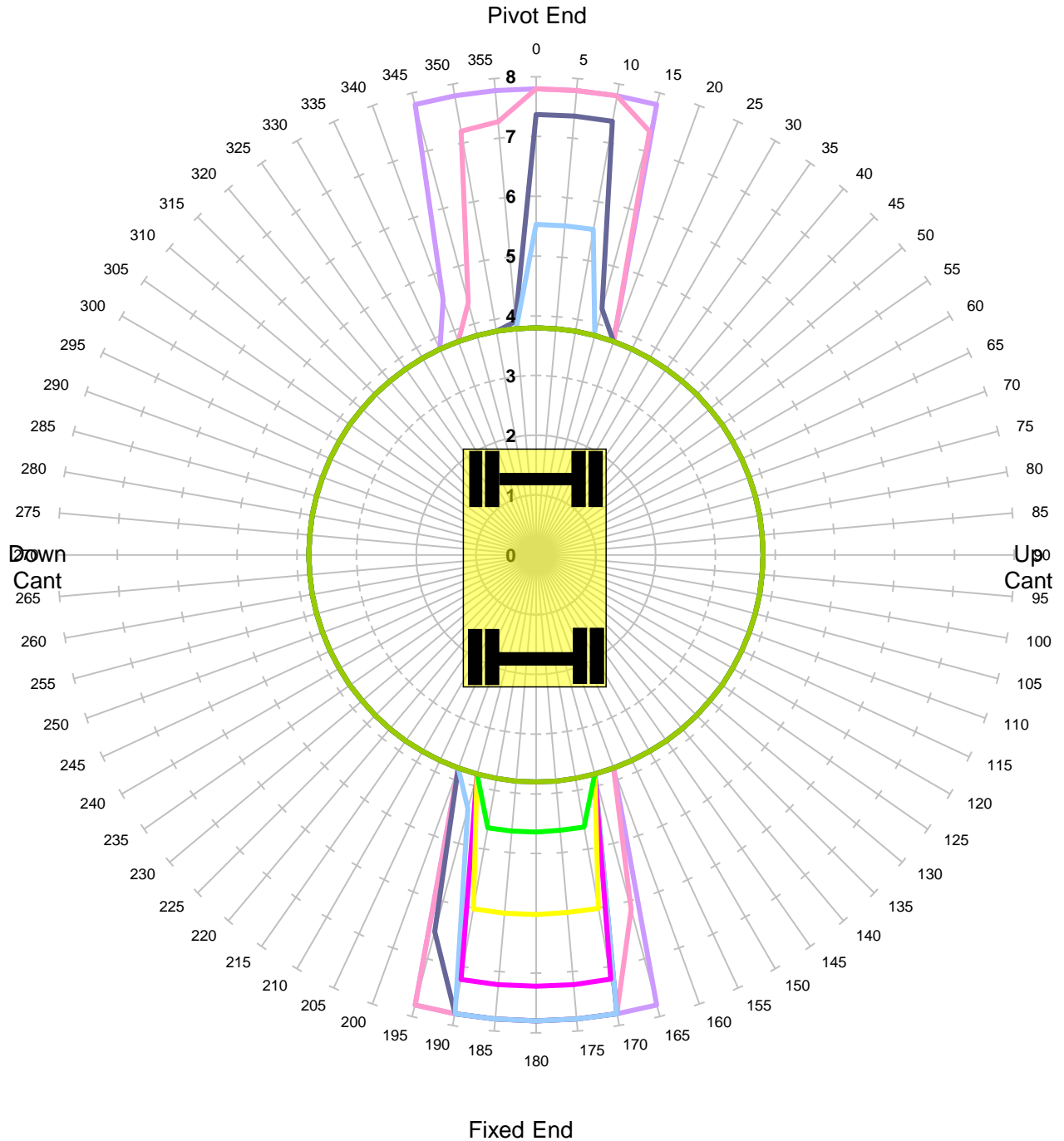

Units in Tonnes

- 1  
 — 2  
 — 3  
 — 4  
 — 5  
 — 6  
 — 7  
 — 8  
 — 9  
 — 10

<b>MACHINE &amp; MODEL:</b>	Colmar T10000FS	<b>REFERENCE:</b>	Dipper Extends by 1000mm
<b>SERIAL No:</b>	8216	<b>DATE OF CHART:</b>	20-May-2019
<b>EQUIPMENT:</b>	4.08m + 2.10m	<b>SAFETY FACTOR:</b>	45.0%
<b>COMMENT:</b>			



## Colmar T10000FS

**Max Capacity Contours of Radius(m) Plots 3.1m Dipper Cwt Out  
Gradient 1 in -25 Height 2m Lift BP**

**Locked Rail Cant -150mm - Tandem Lift**

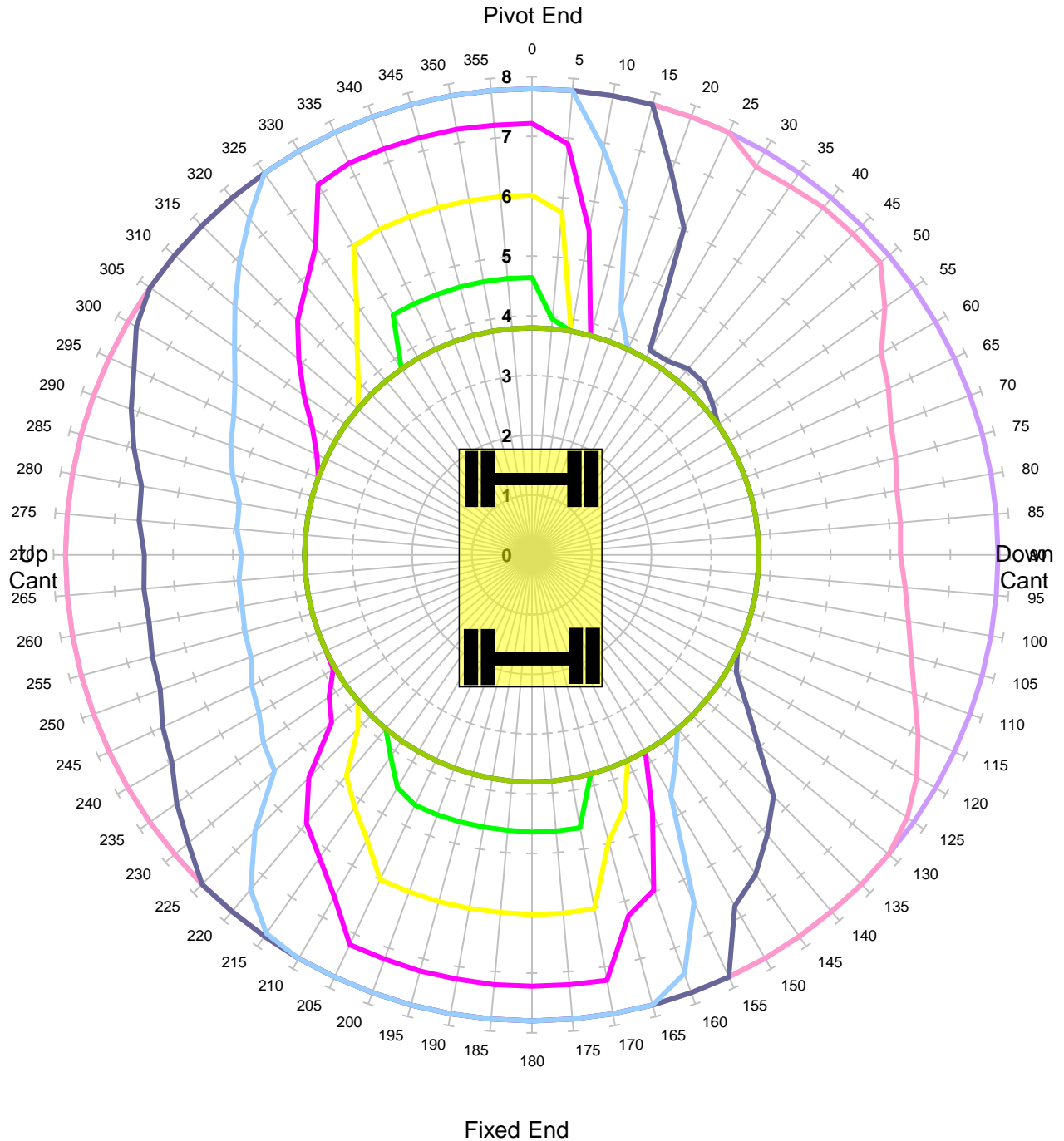

Units in Tonnes

- 1  
 — 2  
 — 3  
 — 4  
 — 5  
 — 6  
 — 7  
 — 8  
 — 9  
 — 10

<b>MACHINE &amp; MODEL:</b>	Colmar T10000FS	<b>REFERENCE:</b>	Dipper Extends by 1000mm
<b>SERIAL No:</b>	8216	<b>DATE OF CHART:</b>	20-May-2019
<b>EQUIPMENT:</b>	4.08m + 2.10m	<b>SAFETY FACTOR:</b>	60.0%
<b>COMMENT:</b>			

## Colmar T10000FS

**Max Capacity Contours of Radius(m) Plots 3.1m Dipper Cwt Out  
Gradient 1 in -25 Height 2m Lift BP**

**Locked Rail Cant -50mm - Tandem Lift**

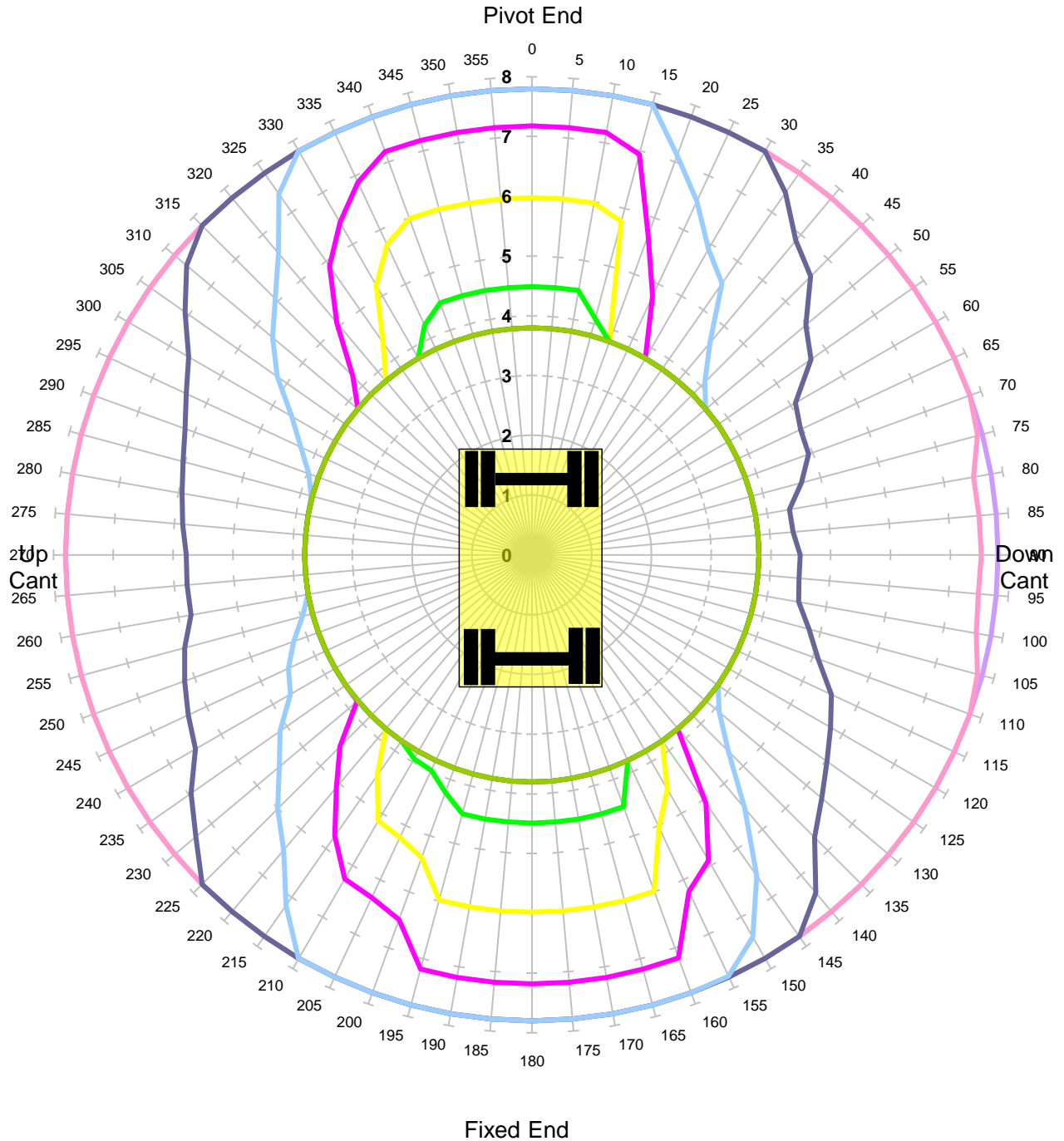

Units in Tonnes

1 2 3 4 5 6 7 8 9 10

<b>MACHINE &amp; MODEL:</b>	Colmar T10000FS	<b>REFERENCE:</b>	Dipper Extends by 1000mm
<b>SERIAL No:</b>	8216	<b>DATE OF CHART:</b>	20-May-2019
<b>EQUIPMENT:</b>	4.08m + 2.10m	<b>SAFETY FACTOR:</b>	60.0%
<b>COMMENT:</b>			

**Colmar T10000FS**  
**Max Capacity Contours of Radius(m) Plots 3.1m Dipper Cwt Out**  
**Gradient 1 in -25 Height 2m Lift BP**  
**Locked Rail Cant 50mm - Tandem Lift**

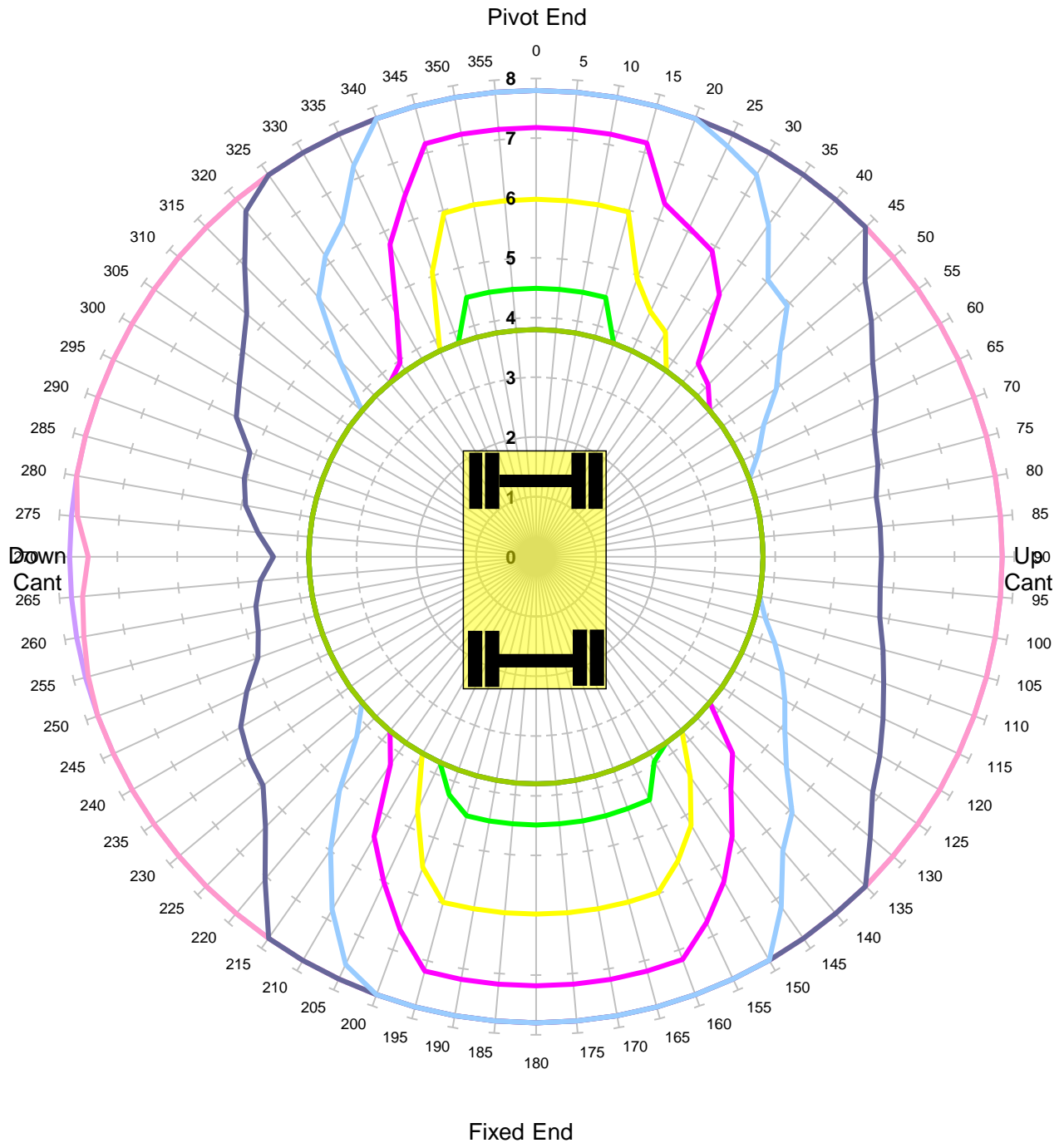

Units in Tonnes

- 1   
 — 2   
 — 3   
 — 4   
 — 5   
 — 6   
 — 7   
 — 8   
 — 9   
 — 10

<b>MACHINE &amp; MODEL:</b>	Colmar T10000FS	<b>REFERENCE:</b>	Dipper Extends by 1000mm
<b>SERIAL No:</b>	8216	<b>DATE OF CHART:</b>	20-May-2019
<b>EQUIPMENT:</b>	4.08m + 2.10m	<b>SAFETY FACTOR:</b>	60.0%
<b>COMMENT:</b>			

## Colmar T10000FS

**Max Capacity Contours of Radius(m) Plots 3.1m Dipper Cwt Out  
Gradient 1 in -25 Height 2m Lift BP**

**Locked Rail Cant 150mm - Tandem Lift**

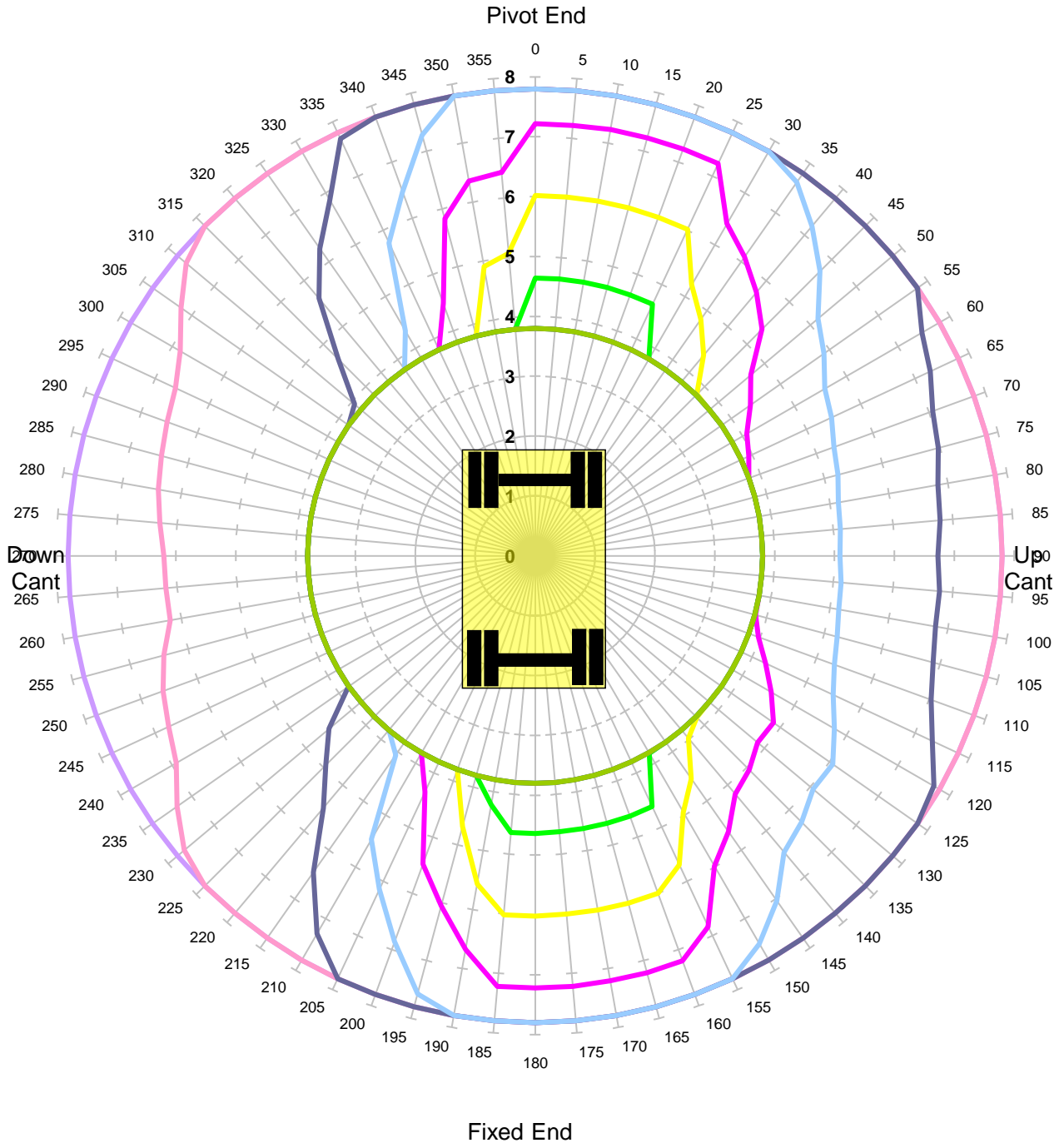

Units in Tonnes

1 2 3 4 5 6 7 8 9 10

<b>MACHINE &amp; MODEL:</b>	Colmar T10000FS	<b>REFERENCE:</b>	Dipper Extends by 1000mm
<b>SERIAL No:</b>	8216	<b>DATE OF CHART:</b>	20-May-2019
<b>EQUIPMENT:</b>	4.08m + 2.10m	<b>SAFETY FACTOR:</b>	60.0%
<b>COMMENT:</b>			

**Colmar T10000FS**  
**Max Capacity Contours of Radius(m) Plots 3.1m Dipper Cwt Out**  
**Level Ground Height 2m Lift BP**  
**Unlocked Road - Tandem Lift**

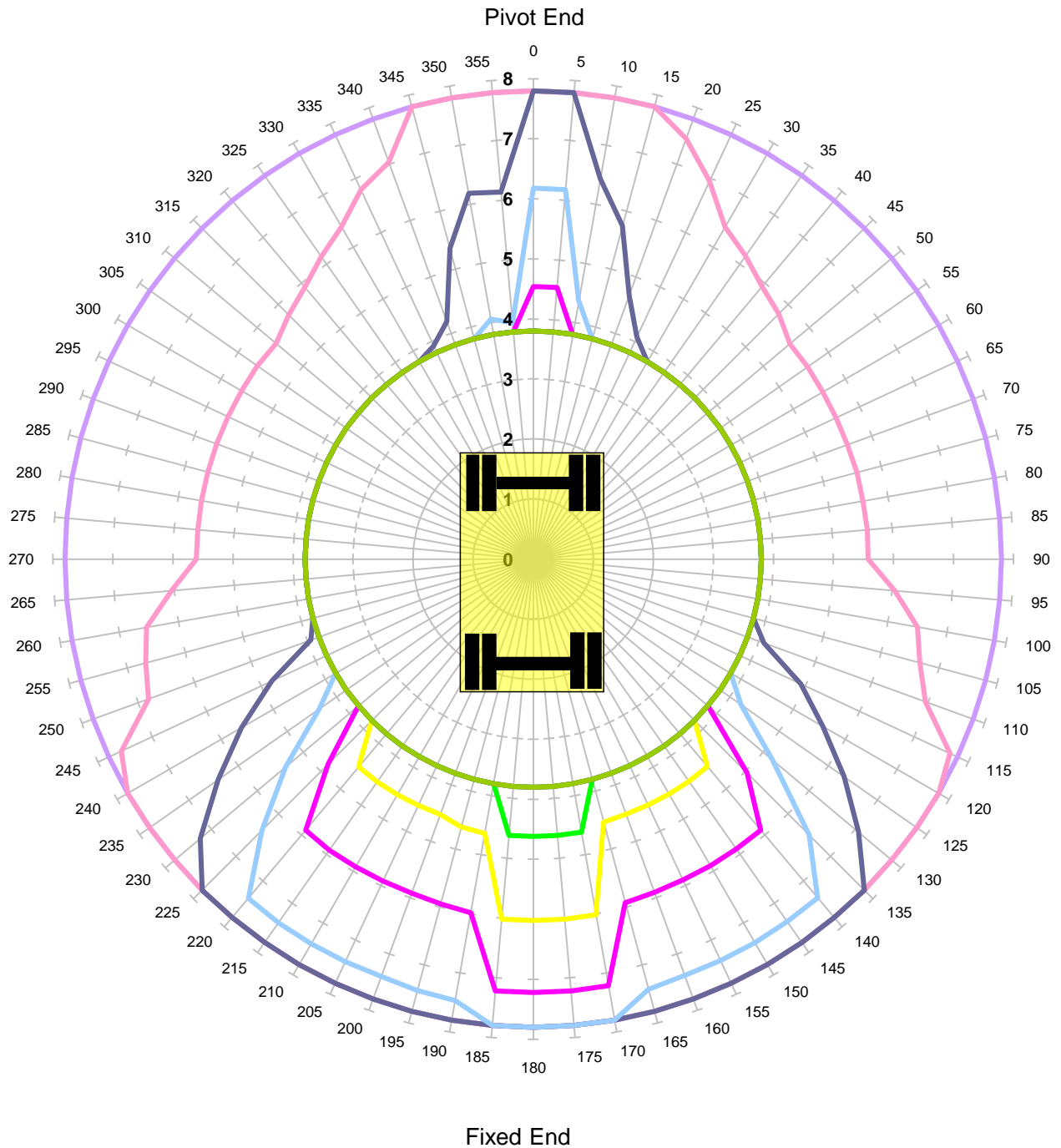

Units in Tonnes

- 1
- 2
- 3
- 4
- 5
- 6
- 7
- 8
- 9
- 10

<b>MACHINE &amp; MODEL:</b>	Colmar T10000FS	<b>REFERENCE:</b>	Dipper Extends by 1000mm
<b>SERIAL No:</b>	8216	<b>DATE OF CHART:</b>	20-May-2019
<b>EQUIPMENT:</b>	4.08m + 2.10m	<b>SAFETY FACTOR:</b>	47.0%
<b>COMMENT:</b>			

**Colmar T10000FS**  
**Max Capacity Contours of Radius(m) Plots 3.1m Dipper Cwt Out**  
**Level Ground Height 2m Lift BP**  
**Locked Road - Tandem Lift**

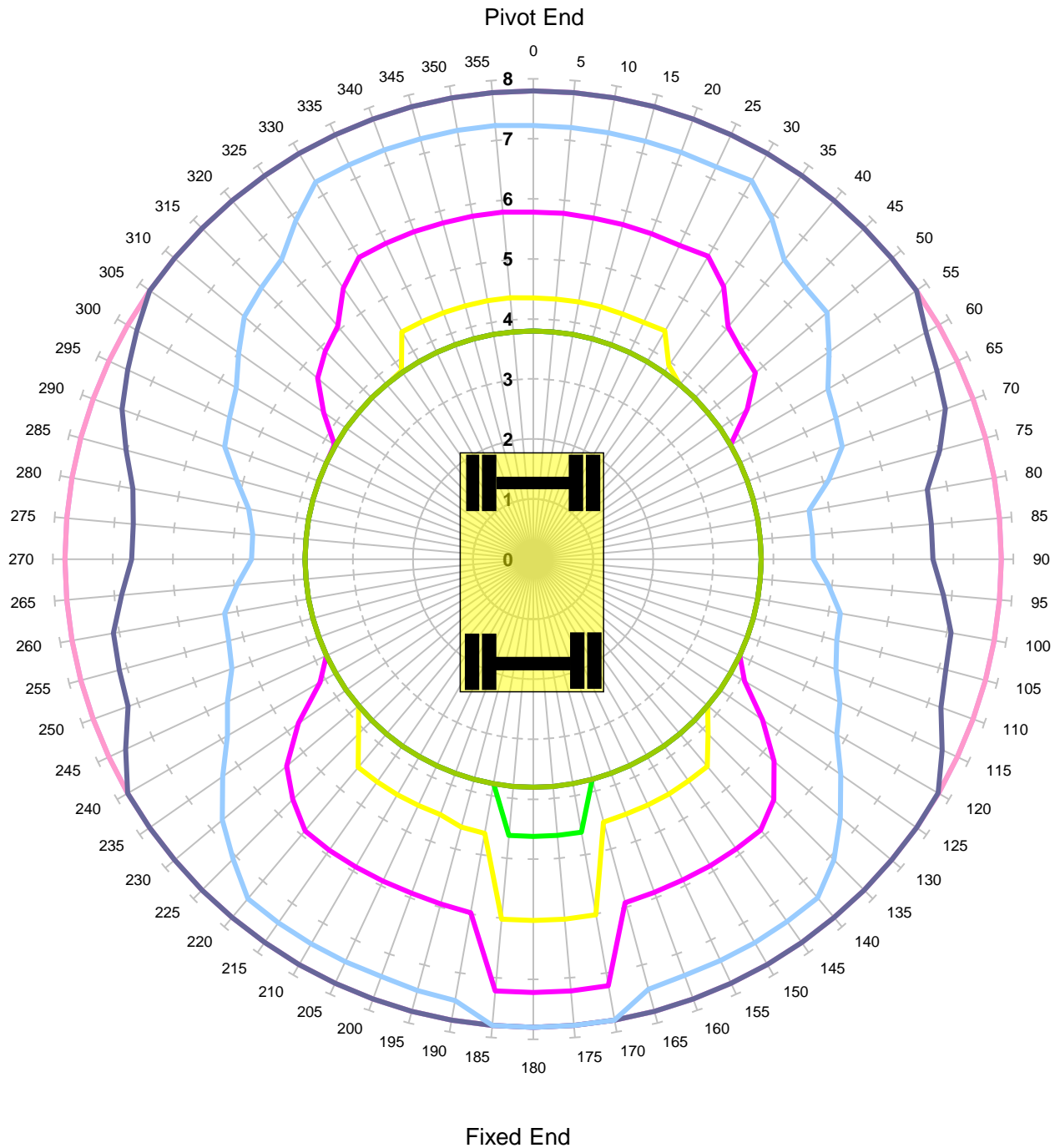

Units in Tonnes

- 1
- 2
- 3
- 4
- 5
- 6
- 7
- 8
- 9
- 10

<b>MACHINE &amp; MODEL:</b>	Colmar T10000FS	<b>REFERENCE:</b>	Dipper Extends by 1000mm
<b>SERIAL No:</b>	8216	<b>DATE OF CHART:</b>	20-May-2019
<b>EQUIPMENT:</b>	4.08m + 2.10m	<b>SAFETY FACTOR:</b>	47.0%
<b>COMMENT:</b>			