

Colmar T10000FS
Max Capacity Contours of Radius(m) Plots 2.1m Dipper Cwt In
Gradient 1 in -25 Height 2m Lift BP
Unlocked Rail Cant -150mm

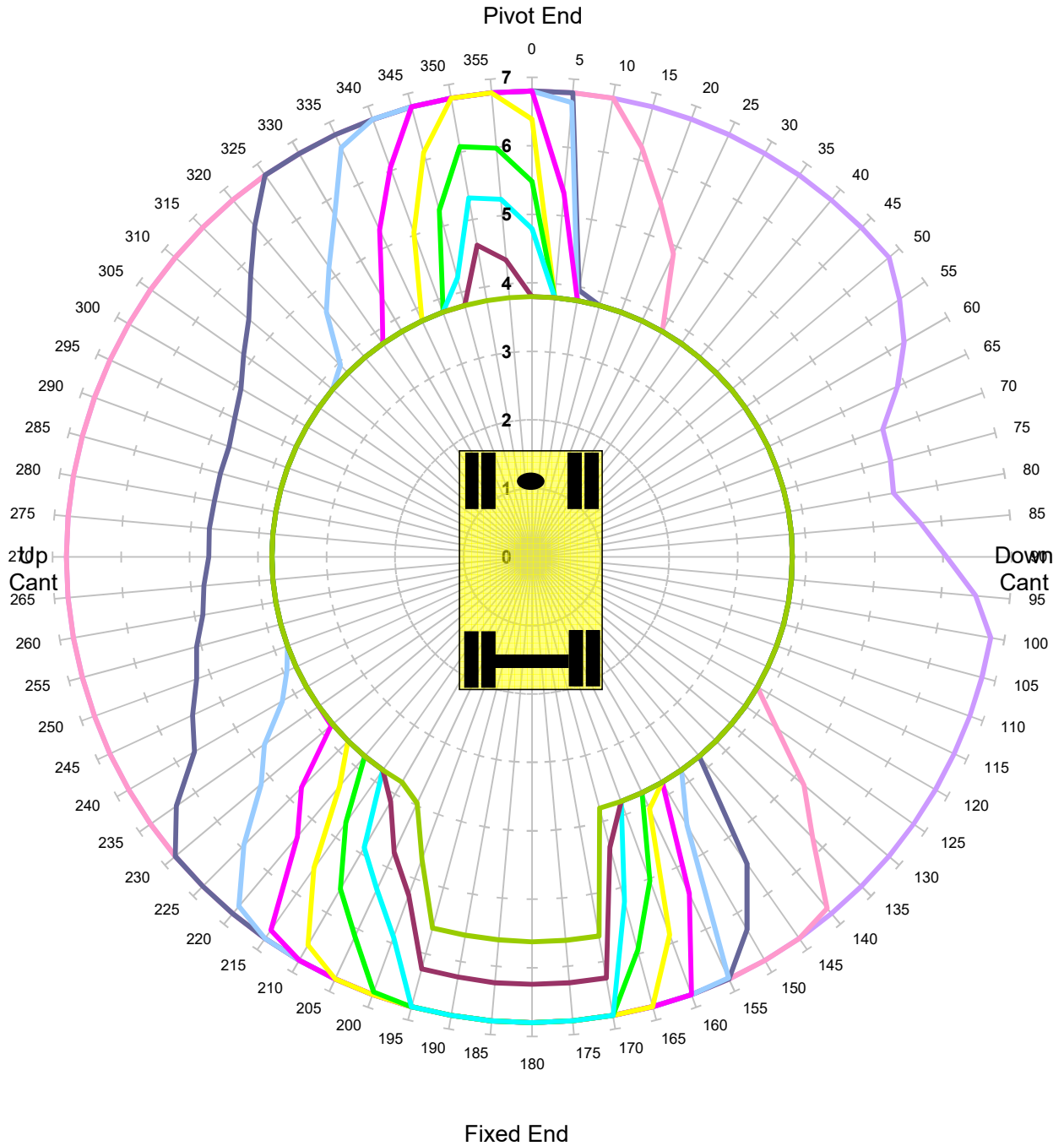

Units in Tonnes
 1 2 3 4 5 6 7 8 9 10

MACHINE & MODEL:	Colmar T10000FS	REFERENCE:	Dipper Extends by 1000mm
SERIAL No:	8443	DATE OF CHART:	29-May-2019
EQUIPMENT:	4.08m + 2.10m	SAFETY FACTOR:	67.0%
COMMENT:			

Colmar T10000FS
Max Capacity Contours of Radius(m) Plots 2.1m Dipper Cwt In
Gradient 1 in -25 Height 2m Lift BP
Unlocked Rail Cant -50mm

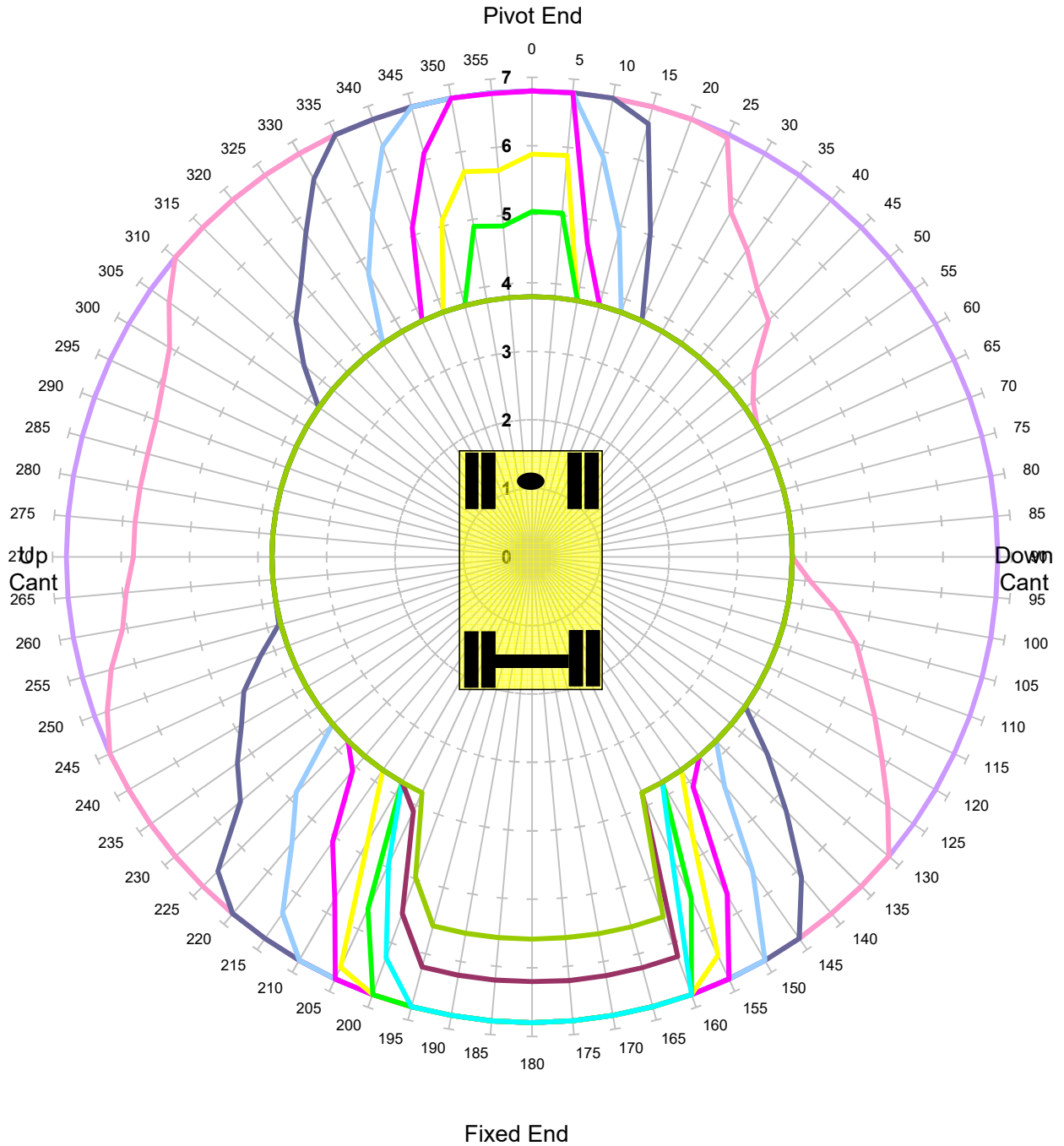

Units in Tonnes

- 1
 — 2
 — 3
 — 4
 — 5
 — 6
 — 7
 — 8
 — 9
 — 10

MACHINE & MODEL:	Colmar T10000FS	REFERENCE:	Dipper Extends by 1000mm
SERIAL No:	8443	DATE OF CHART:	29-May-2019
EQUIPMENT:	4.08m + 2.10m	SAFETY FACTOR:	67.0%
COMMENT:			

Colmar T10000FS
Max Capacity Contours of Radius(m) Plots 2.1m Dipper Cwt In
Gradient 1 in -25 Height 2m Lift BP
Unlocked Rail Cant 50mm

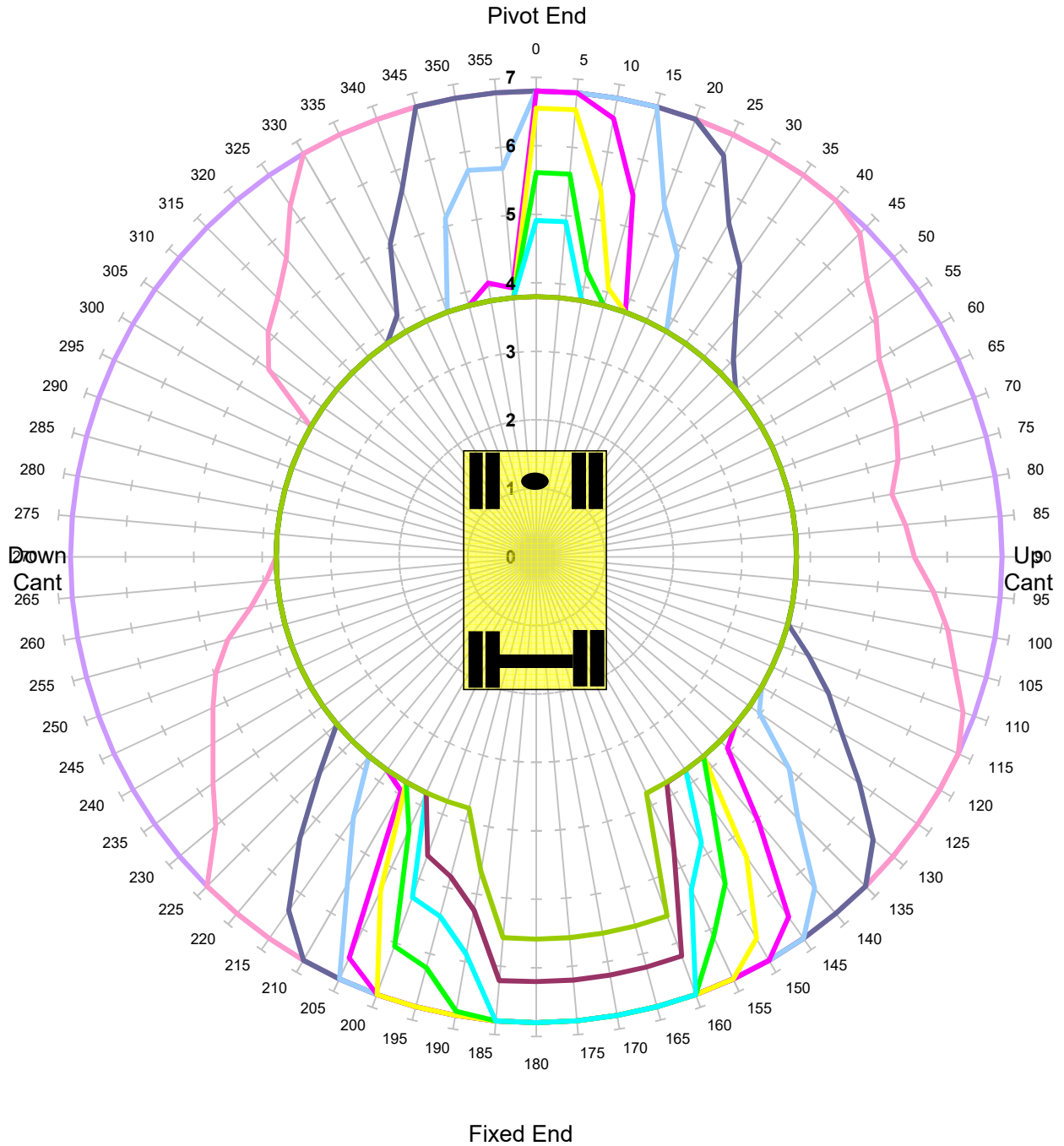

Units in Tonnes

- 1
- 2
- 3
- 4
- 5
- 6
- 7
- 8
- 9
- 10

MACHINE & MODEL:	Colmar T10000FS	REFERENCE:	Dipper Extends by 1000mm
SERIAL No:	8443	DATE OF CHART:	29-May-2019
EQUIPMENT:	4.08m + 2.10m	SAFETY FACTOR:	67.0%
COMMENT:			

Colmar T10000FS
Max Capacity Contours of Radius(m) Plots 2.1m Dipper Cwt In
Gradient 1 in -25 Height 2m Lift BP
Unlocked Rail Cant 150mm

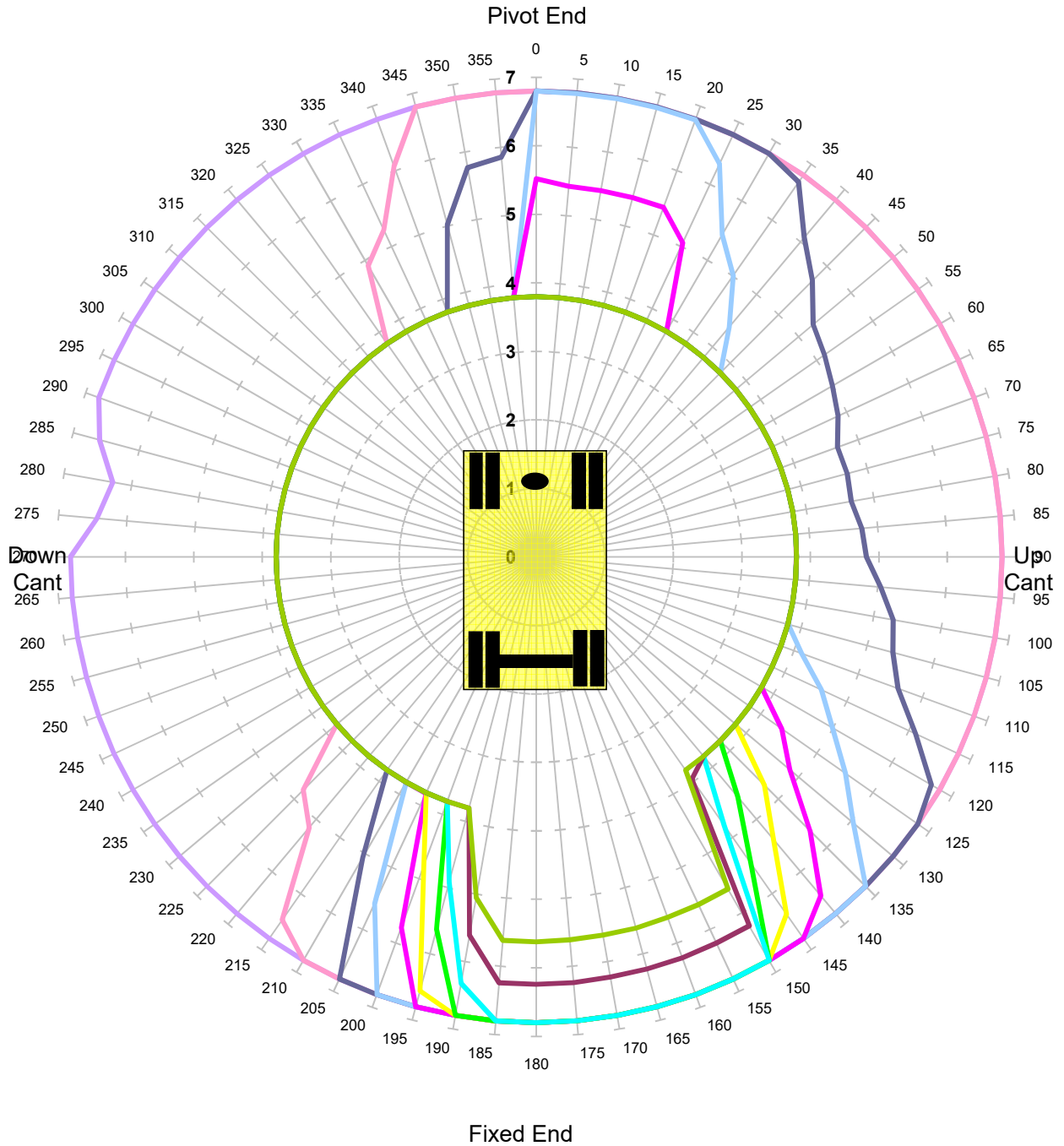

Units in Tonnes

- 1
- 2
- 3
- 4
- 5
- 6
- 7
- 8
- 9
- 10

MACHINE & MODEL:	Colmar T10000FS	REFERENCE:	Dipper Extends by 1000mm
SERIAL No:	8443	DATE OF CHART:	29-May-2019
EQUIPMENT:	4.08m + 2.10m	SAFETY FACTOR:	67.0%
COMMENT:			

Colmar T10000FS
Max Capacity Contours of Radius(m) Plots 2.1m Dipper Cwt In
Gradient 1 in -25 Height 2m Lift BP
Locked Rail Cant -150mm

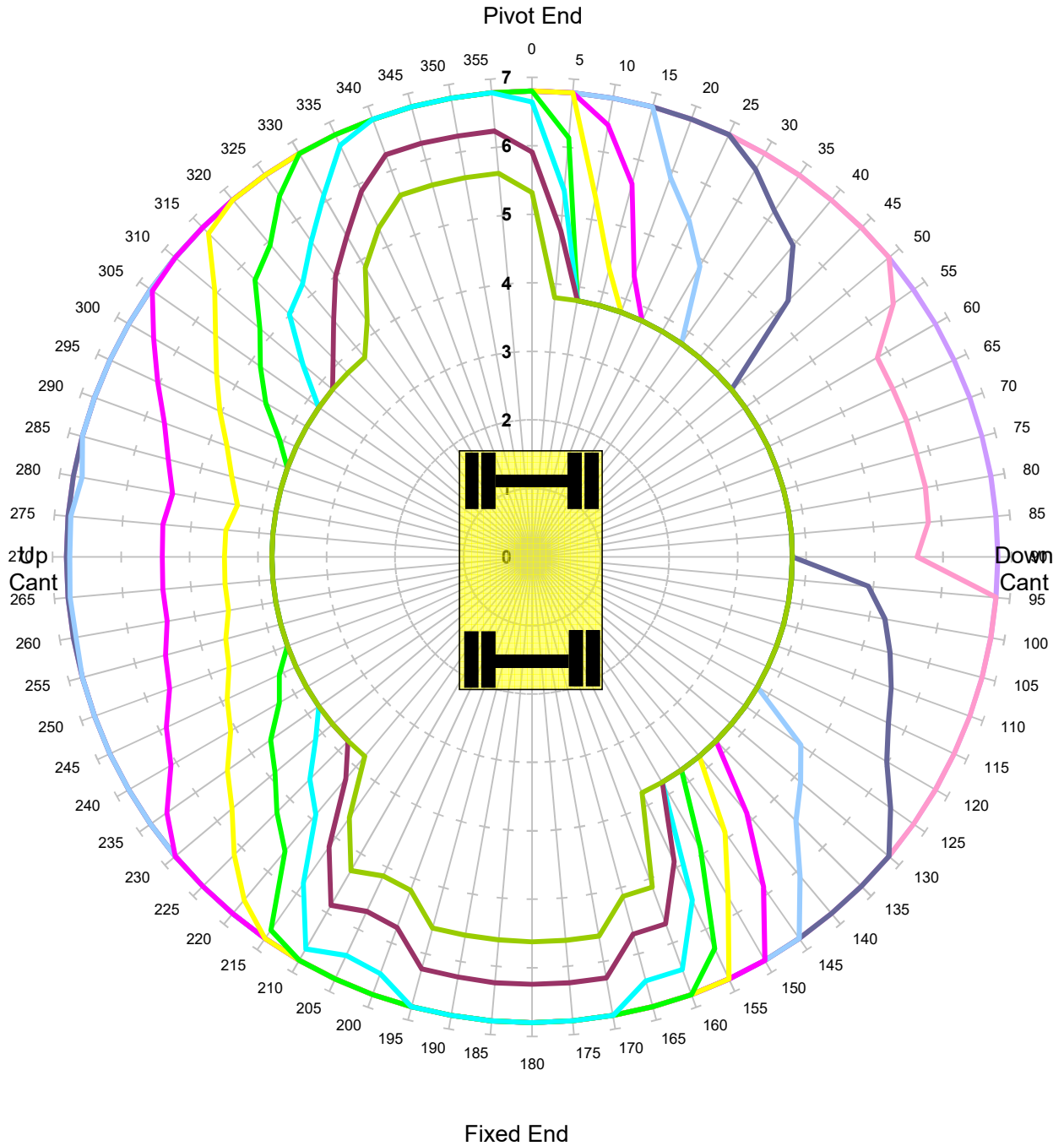

Units in Tonnes

- 1
- 2
- 3
- 4
- 5
- 6
- 7
- 8
- 9
- 10

MACHINE & MODEL:	Colmar T10000FS	REFERENCE:	Dipper Extends by 1000mm
SERIAL No:	8443	DATE OF CHART:	29-May-2019
EQUIPMENT:	4.08m + 2.10m	SAFETY FACTOR:	90.0%
COMMENT:			

Colmar T10000FS
Max Capacity Contours of Radius(m) Plots 2.1m Dipper Cwt In
Gradient 1 in -25 Height 2m Lift BP
Locked Rail Cant -50mm

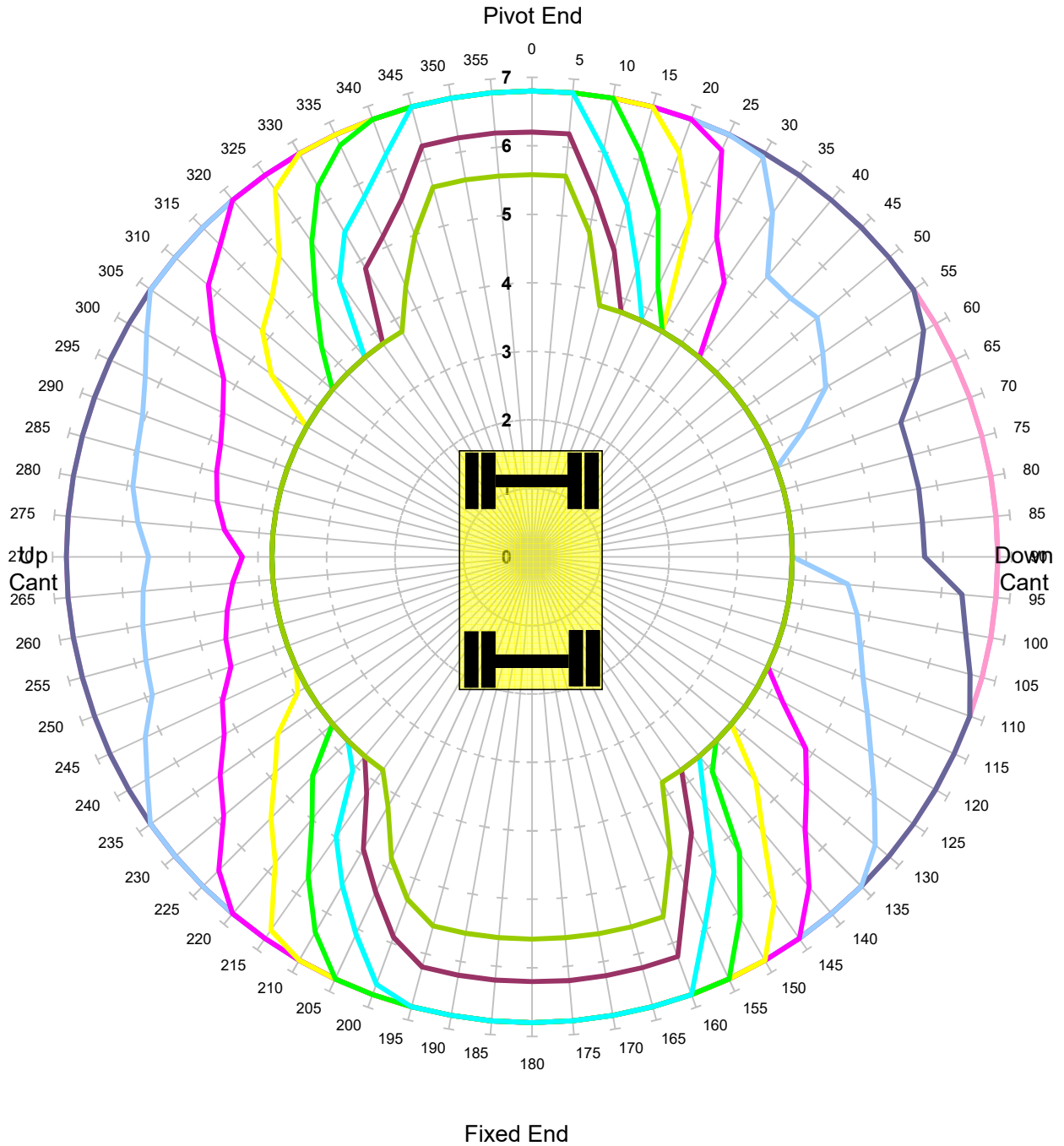

Units in Tonnes

- 1
- 2
- 3
- 4
- 5
- 6
- 7
- 8
- 9
- 10

MACHINE & MODEL:	Colmar T10000FS	REFERENCE:	Dipper Extends by 1000mm
SERIAL No:	8443	DATE OF CHART:	29-May-2019
EQUIPMENT:	4.08m + 2.10m	SAFETY FACTOR:	90.0%
COMMENT:			

Colmar T10000FS
Max Capacity Contours of Radius(m) Plots 2.1m Dipper Cwt In
Gradient 1 in -25 Height 2m Lift BP
Locked Rail Cant 50mm

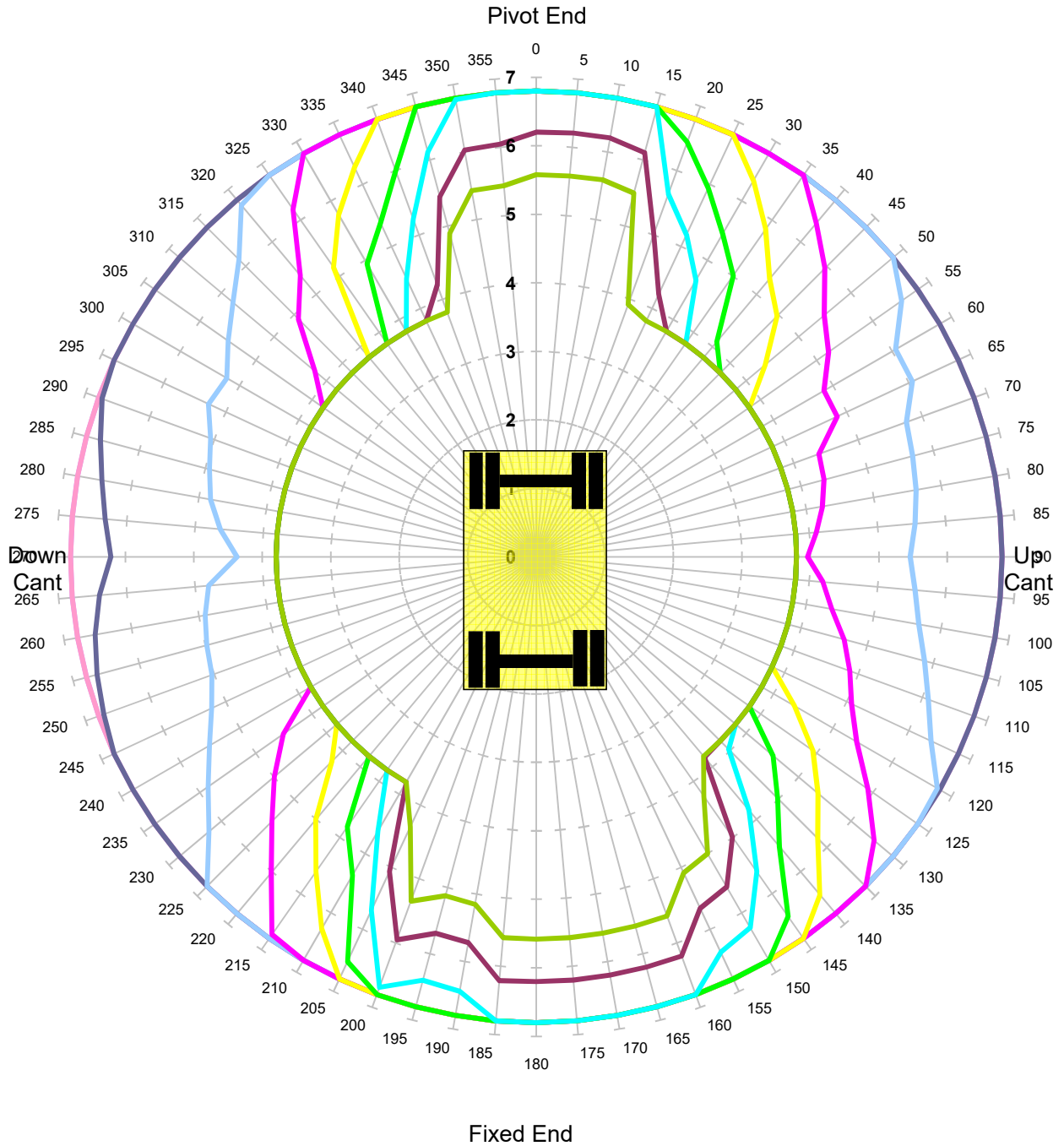

Units in Tonnes

- 1
- 2
- 3
- 4
- 5
- 6
- 7
- 8
- 9
- 10

MACHINE & MODEL:	Colmar T10000FS	REFERENCE:	Dipper Extends by 1000mm
SERIAL No:	8443	DATE OF CHART:	29-May-2019
EQUIPMENT:	4.08m + 2.10m	SAFETY FACTOR:	90.0%
COMMENT:			

Colmar T10000FS
Max Capacity Contours of Radius(m) Plots 2.1m Dipper Cwt In
Gradient 1 in -25 Height 2m Lift BP
Locked Rail Cant 150mm

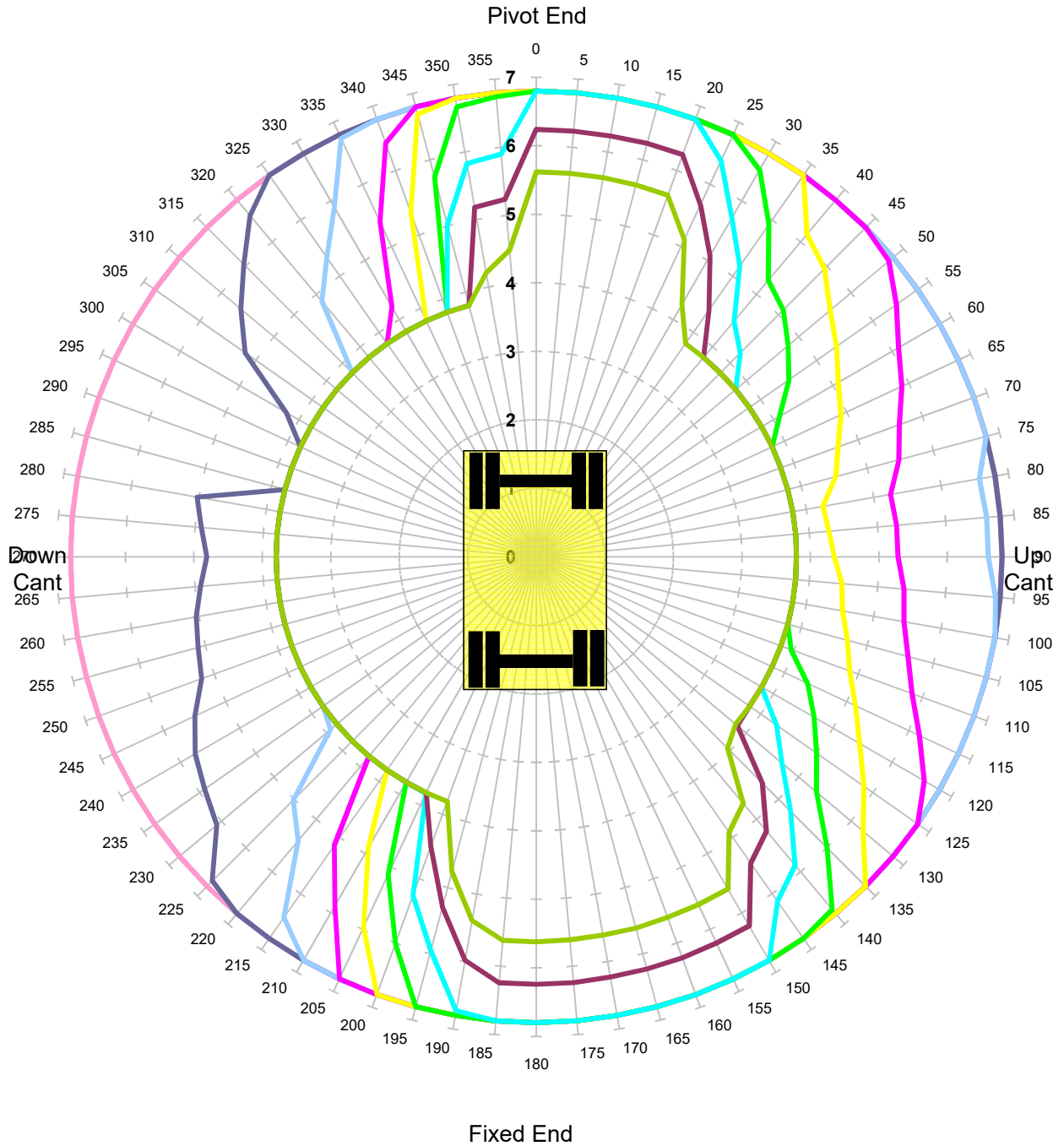

Units in Tonnes

- 1
- 2
- 3
- 4
- 5
- 6
- 7
- 8
- 9
- 10

MACHINE & MODEL:	Colmar T10000FS	REFERENCE:	Dipper Extends by 1000mm
SERIAL No:	8443	DATE OF CHART:	29-May-2019
EQUIPMENT:	4.08m + 2.10m	SAFETY FACTOR:	90.0%
COMMENT:			

Colmar T10000FS
Max Capacity Contours of Radius(m) Plots 2.1m Dipper Cwt In
Level Ground Height 2m Lift BP
Unlocked Road

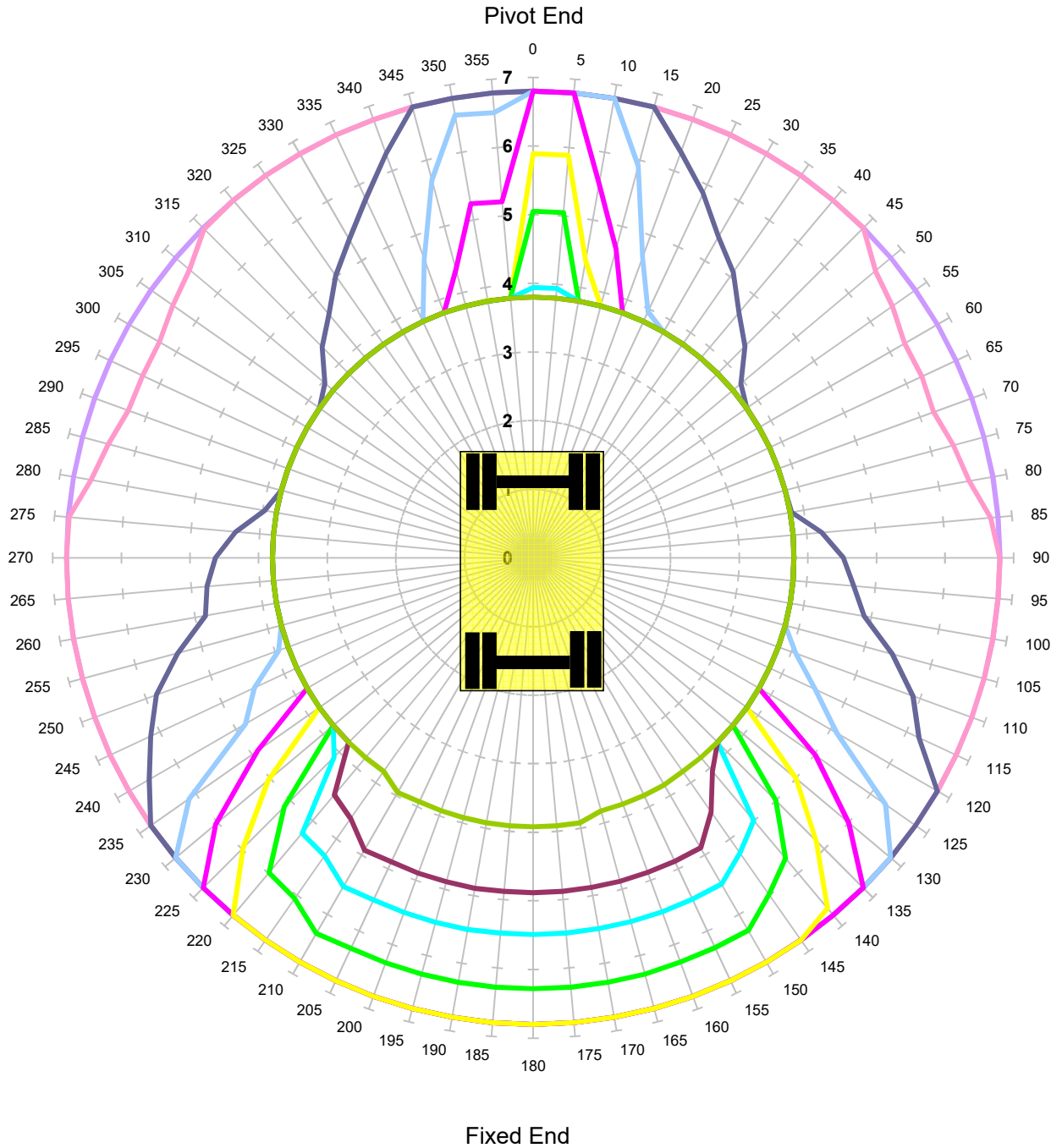

Units in Tonnes

- 1
- 2
- 3
- 4
- 5
- 6
- 7
- 8
- 9
- 10

MACHINE & MODEL:	Colmar T10000FS	REFERENCE:	Dipper Extends by 1000mm
SERIAL No:	8443	DATE OF CHART:	29-May-2019
EQUIPMENT:	4.08m + 2.10m	SAFETY FACTOR:	71.0%
COMMENT:			

Colmar T10000FS
Max Capacity Contours of Radius(m) Plots 2.1m Dipper Cwt In
Level Ground Height 2m Lift BP
Locked Road

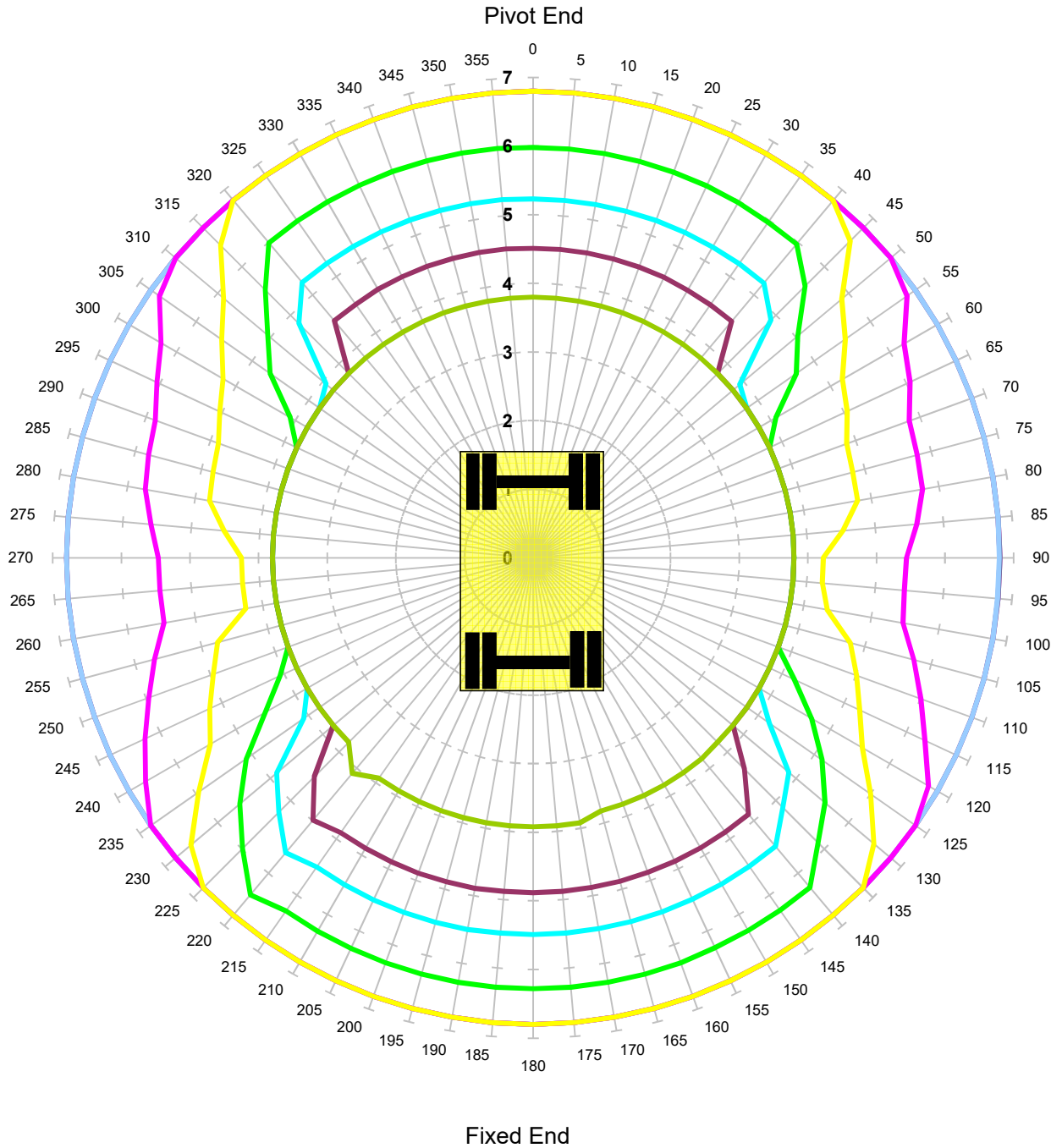

Units in Tonnes

- 1
 — 2
 — 3
 — 4
 — 5
 — 6
 — 7
 — 8
 — 9
 — 10

MACHINE & MODEL:	Colmar T10000FS	REFERENCE:	Dipper Extends by 1000mm
SERIAL No:	8443	DATE OF CHART:	29-May-2019
EQUIPMENT:	4.08m + 2.10m	SAFETY FACTOR:	71.0%
COMMENT:			

Colmar T10000FS

**Max Capacity Contours of Radius(m) Plots 2.1m Dipper Cwt In
Gradient 1 in -25 Height 2m Lift BP**

Unlocked Rail Cant -150mm - Tandem Lift

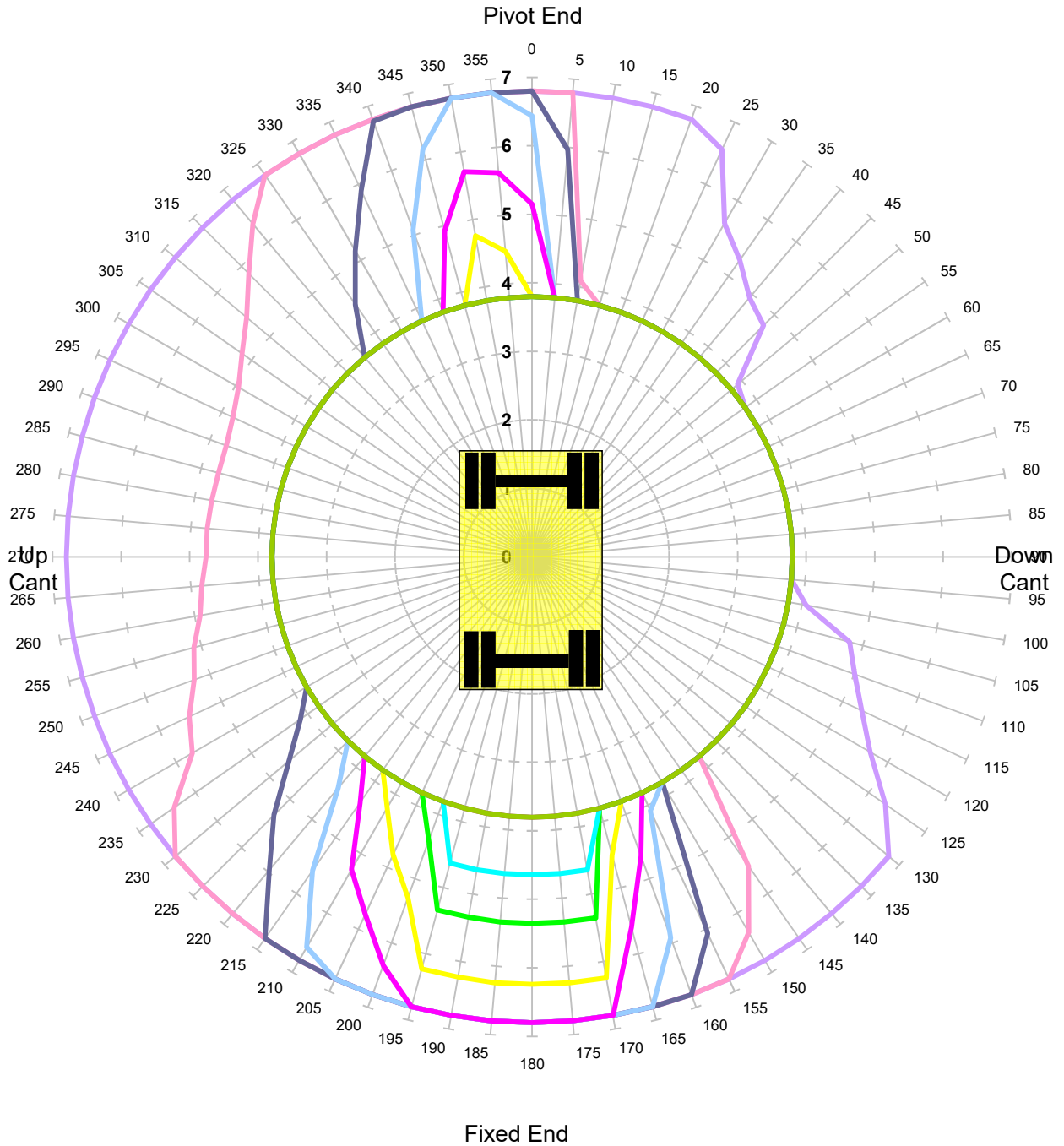

Units in Tonnes

- 1
 — 2
 — 3
 — 4
 — 5
 — 6
 — 7
 — 8
 — 9
 — 10

MACHINE & MODEL:	Colmar T10000FS	REFERENCE:	Dipper Extends by 1000mm
SERIAL No:	8443	DATE OF CHART:	29-May-2019
EQUIPMENT:	4.08m + 2.10m	SAFETY FACTOR:	45.0%
COMMENT:			

Colmar T10000FS

**Max Capacity Contours of Radius(m) Plots 2.1m Dipper Cwt In
Gradient 1 in -25 Height 2m Lift BP**

Unlocked Rail Cant -50mm - Tandem Lift

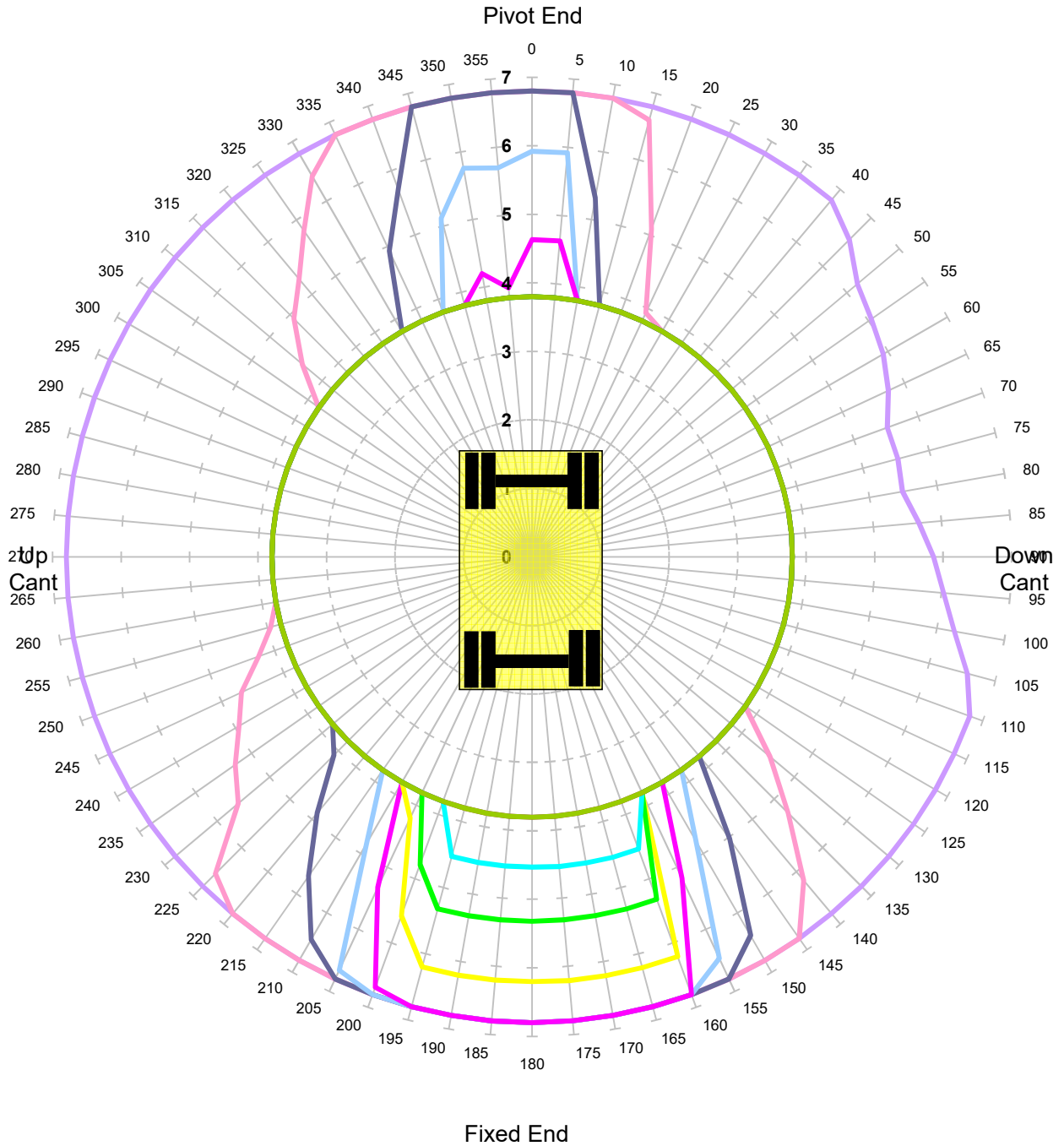

Units in Tonnes

- 1
 — 2
 — 3
 — 4
 — 5
 — 6
 — 7
 — 8
 — 9
 — 10

MACHINE & MODEL:	Colmar T10000FS	REFERENCE:	Dipper Extends by 1000mm
SERIAL No:	8443	DATE OF CHART:	29-May-2019
EQUIPMENT:	4.08m + 2.10m	SAFETY FACTOR:	45.0%
COMMENT:			

Colmar T10000FS

**Max Capacity Contours of Radius(m) Plots 2.1m Dipper Cwt In
Gradient 1 in -25 Height 2m Lift BP**

Unlocked Rail Cant 50mm - Tandem Lift

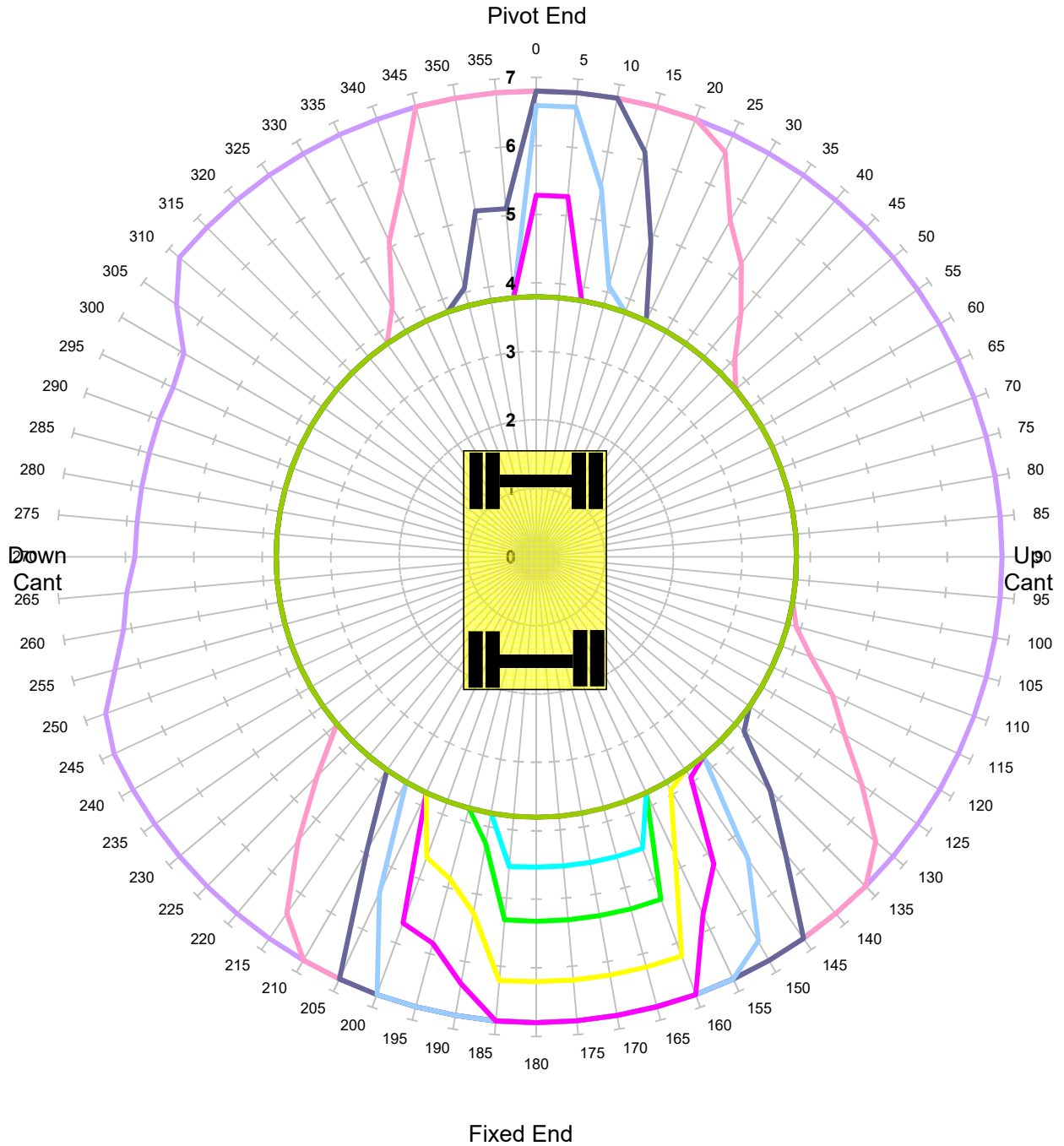

Units in Tonnes

- 1
- 2
- 3
- 4
- 5
- 6
- 7
- 8
- 9
- 10

MACHINE & MODEL:	Colmar T10000FS	REFERENCE:	Dipper Extends by 1000mm
SERIAL No:	8443	DATE OF CHART:	29-May-2019
EQUIPMENT:	4.08m + 2.10m	SAFETY FACTOR:	45.0%
COMMENT:			

Colmar T10000FS

**Max Capacity Contours of Radius(m) Plots 2.1m Dipper Cwt In
Gradient 1 in -25 Height 2m Lift BP**

Unlocked Rail Cant 150mm - Tandem Lift

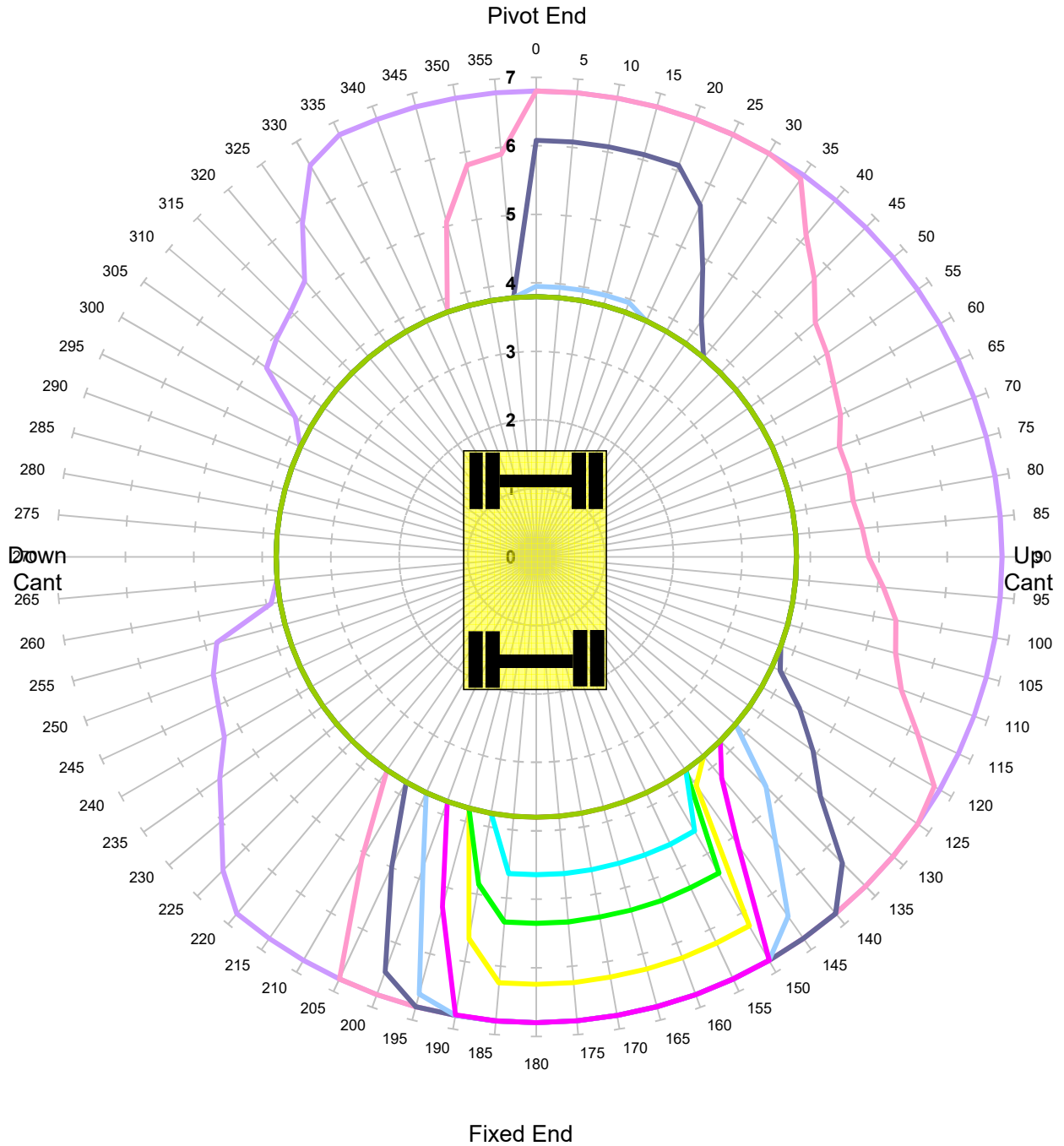

Units in Tonnes

- 1
 — 2
 — 3
 — 4
 — 5
 — 6
 — 7
 — 8
 — 9
 — 10

MACHINE & MODEL:	Colmar T10000FS	REFERENCE:	Dipper Extends by 1000mm
SERIAL No:	8443	DATE OF CHART:	29-May-2019
EQUIPMENT:	4.08m + 2.10m	SAFETY FACTOR:	45.0%
COMMENT:			

Colmar T10000FS

**Max Capacity Contours of Radius(m) Plots 2.1m Dipper Cwt In
Gradient 1 in -25 Height 2m Lift BP**

Locked Rail Cant -150mm - Tandem Lift

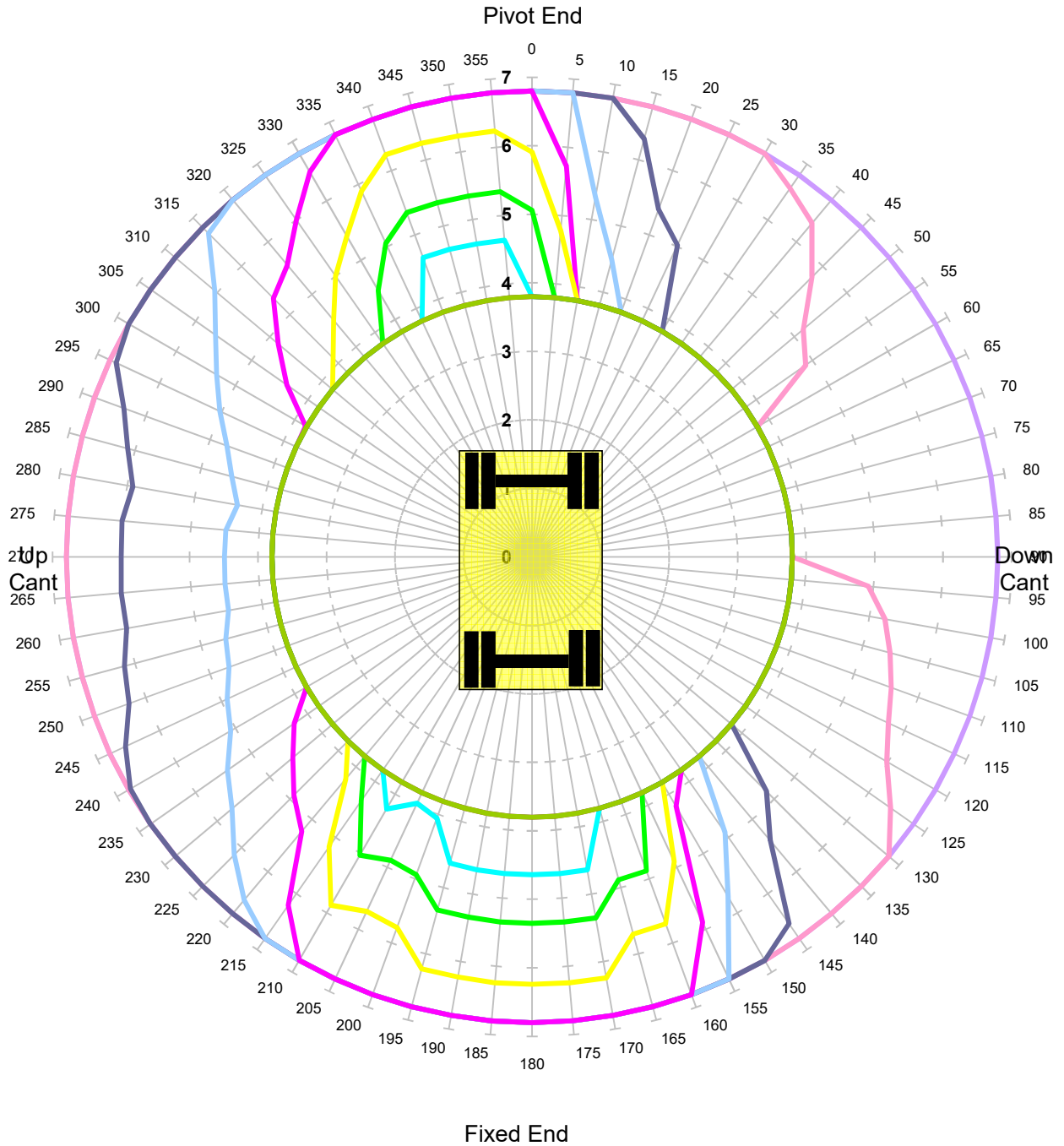

Units in Tonnes

- 1
 — 2
 — 3
 — 4
 — 5
 — 6
 — 7
 — 8
 — 9
 — 10

MACHINE & MODEL:	Colmar T10000FS	REFERENCE:	Dipper Extends by 1000mm
SERIAL No:	8443	DATE OF CHART:	29-May-2019
EQUIPMENT:	4.08m + 2.10m	SAFETY FACTOR:	60.0%
COMMENT:			

Colmar T1000FS

**Max Capacity Contours of Radius(m) Plots 2.1m Dipper Cwt In
Gradient 1 in -25 Height 2m Lift BP**

Locked Rail Cant -50mm - Tandem Lift

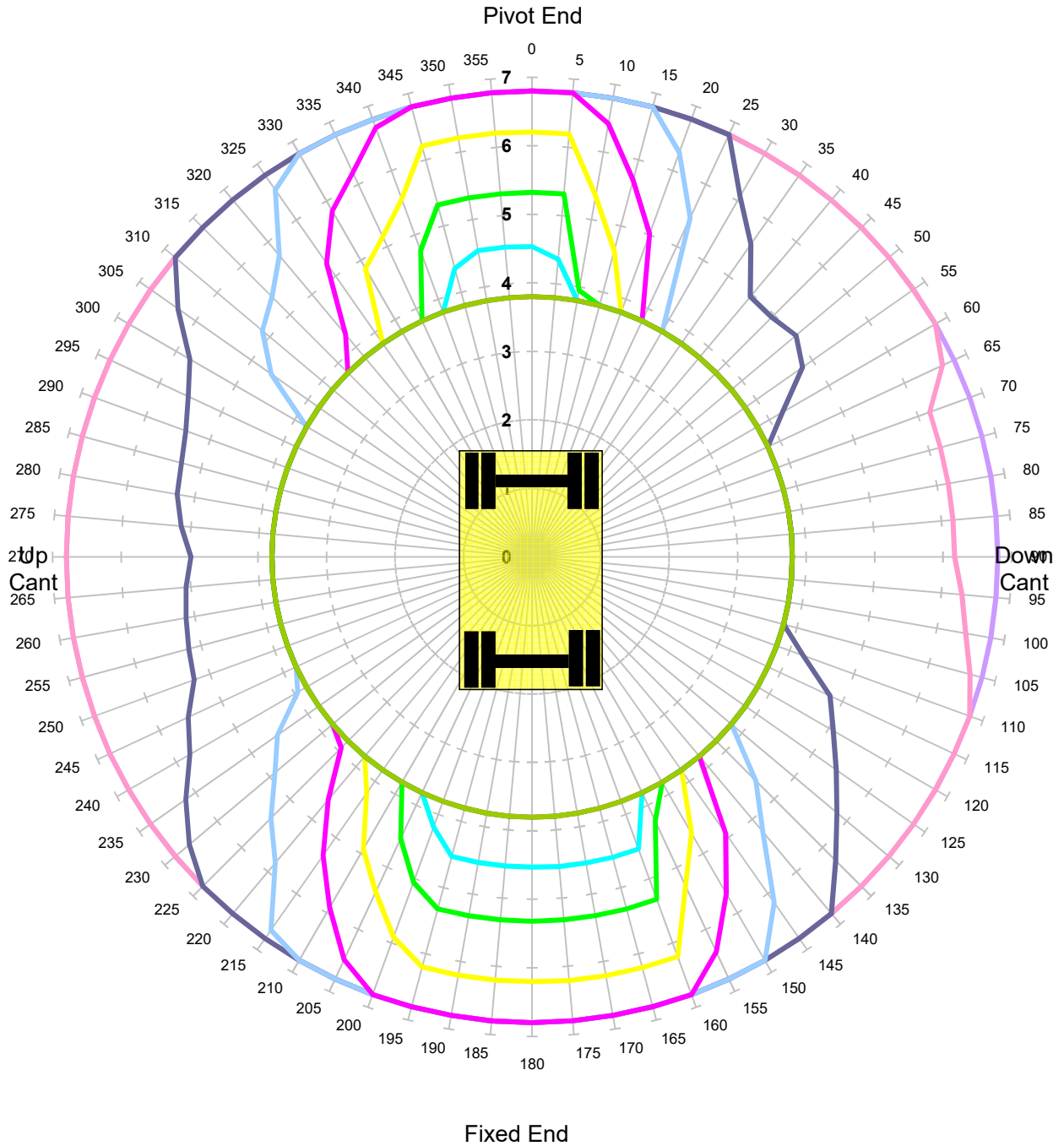

Units in Tonnes

1 2 3 4 5 6 7 8 9 10

MACHINE & MODEL:	Colmar T1000FS	REFERENCE:	Dipper Extends by 1000mm
SERIAL No:	8443	DATE OF CHART:	29-May-2019
EQUIPMENT:	4.08m + 2.10m	SAFETY FACTOR:	60.0%
COMMENT:			

Colmar T10000FS
Max Capacity Contours of Radius(m) Plots 2.1m Dipper Cwt In
Gradient 1 in -25 Height 2m Lift BP
Locked Rail Cant 50mm - Tandem Lift

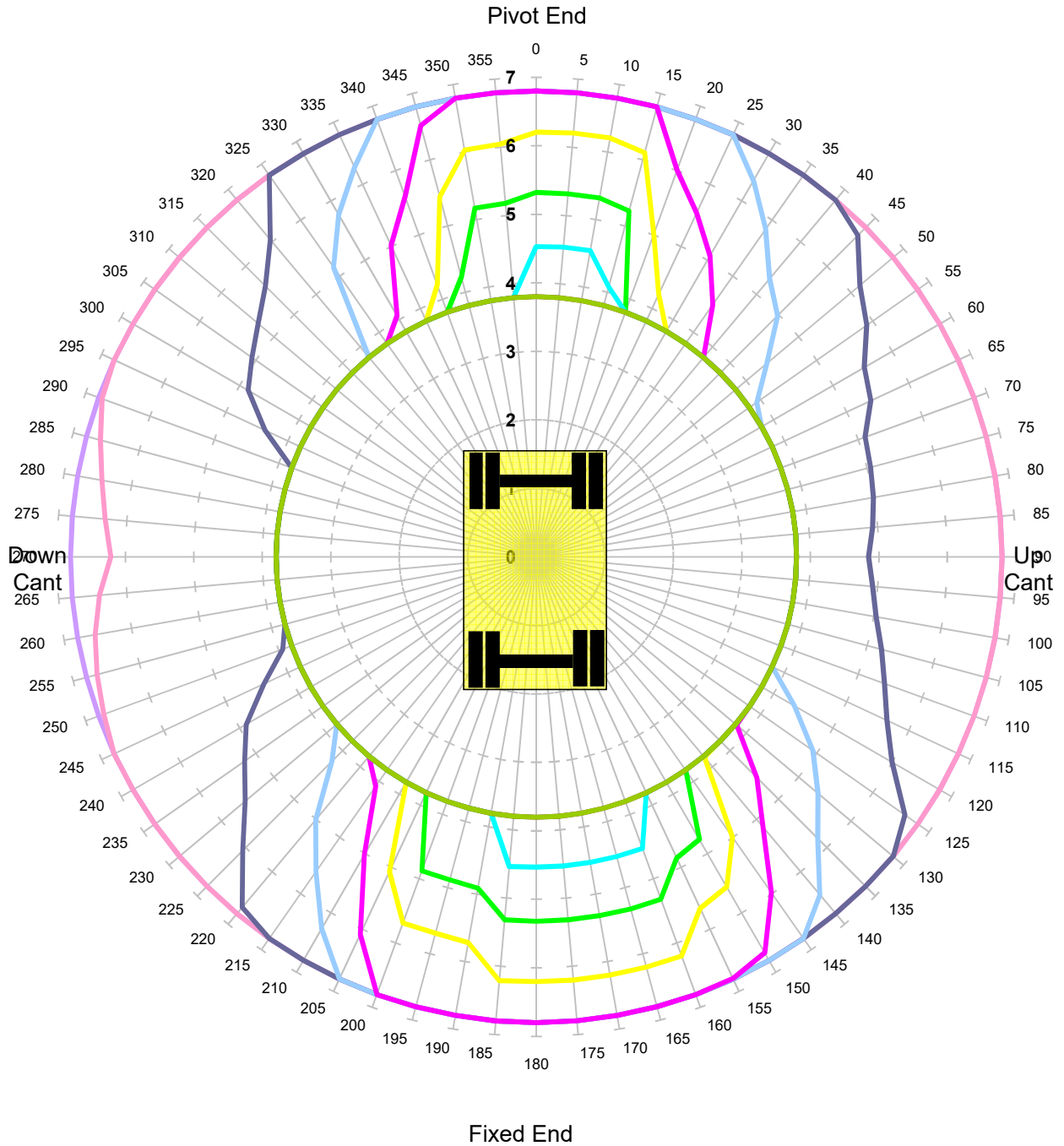

Units in Tonnes

- 1
 — 2
 — 3
 — 4
 — 5
 — 6
 — 7
 — 8
 — 9
 — 10

MACHINE & MODEL:	Colmar T10000FS	REFERENCE:	Dipper Extends by 1000mm
	SERIAL No: 8443		DATE OF CHART: 29-May-2019
EQUIPMENT:	4.08m + 2.10m	SAFETY FACTOR:	60.0%
COMMENT:			

Colmar T10000FS

**Max Capacity Contours of Radius(m) Plots 2.1m Dipper Cwt In
Gradient 1 in -25 Height 2m Lift BP**

Locked Rail Cant 150mm - Tandem Lift

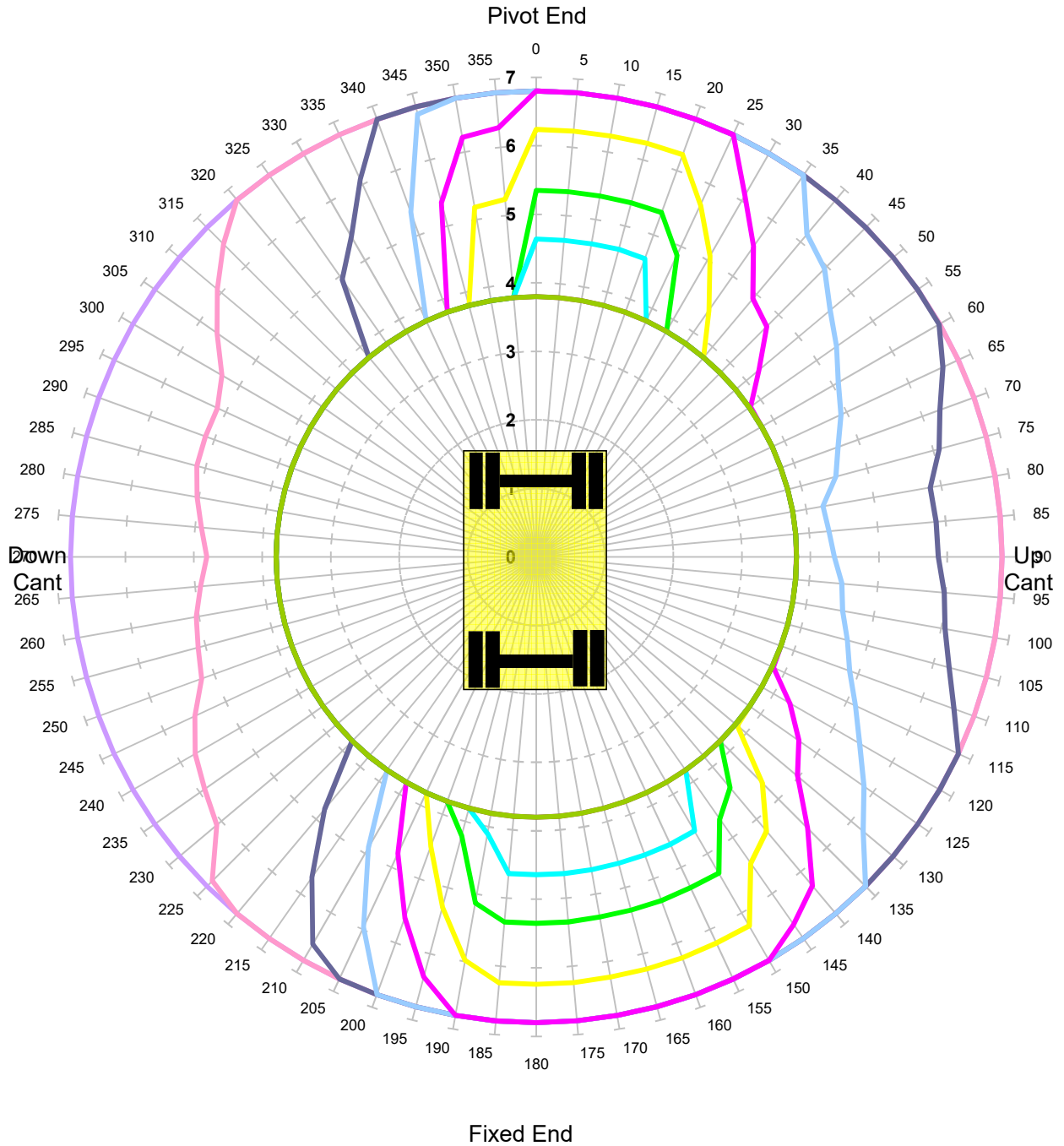

Units in Tonnes

- 1
 — 2
 — 3
 — 4
 — 5
 — 6
 — 7
 — 8
 — 9
 — 10

MACHINE & MODEL:	Colmar T10000FS	REFERENCE:	Dipper Extends by 1000mm
SERIAL No:	8443	DATE OF CHART:	29-May-2019
EQUIPMENT:	4.08m + 2.10m	SAFETY FACTOR:	60.0%
COMMENT:			

Colmar T10000FS
Max Capacity Contours of Radius(m) Plots 2.1m Dipper Cwt In
Level Ground Height 2m Lift BP
Unlocked Road - Tandem Lift

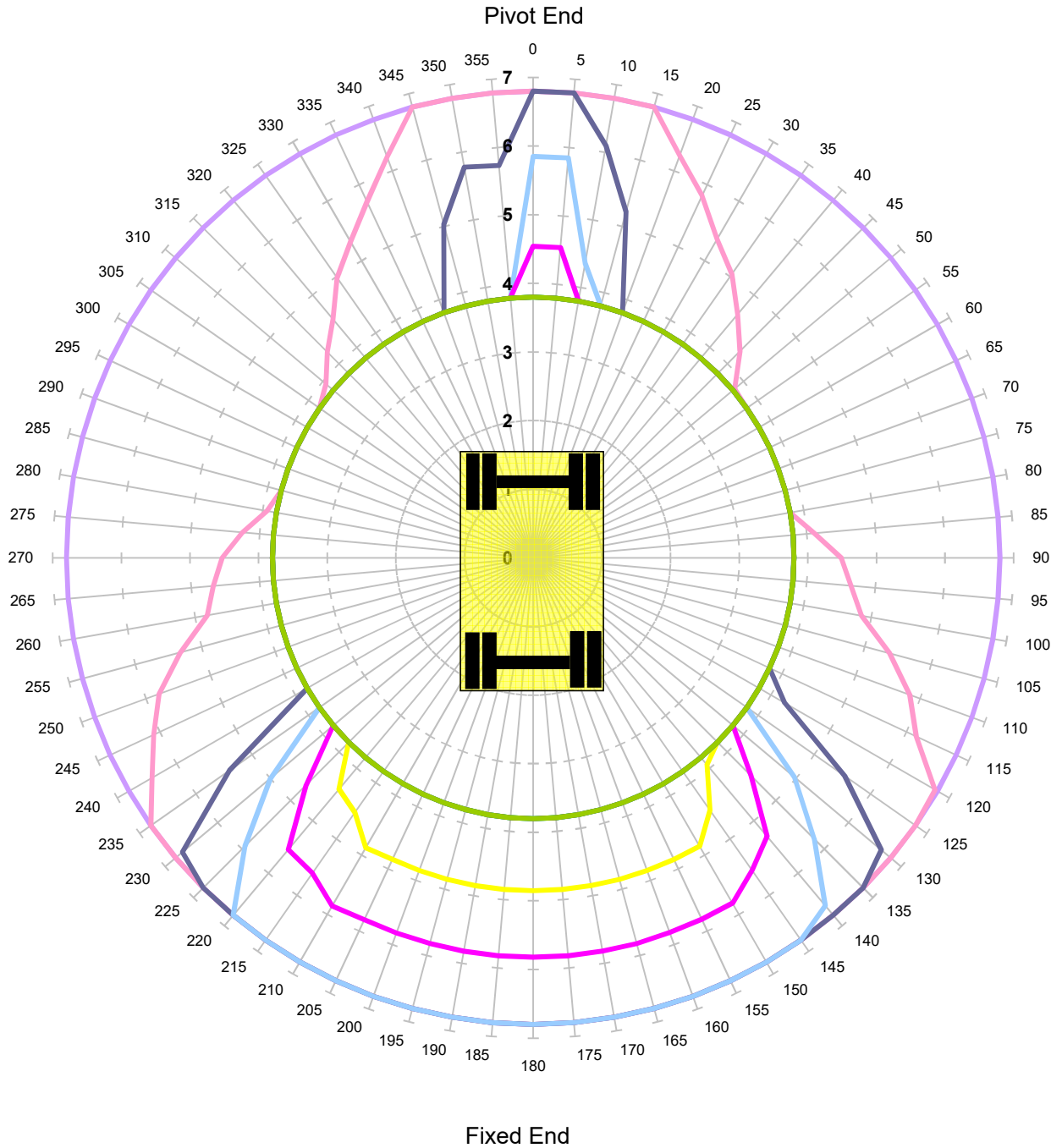

Units in Tonnes

- 1
 — 2
 — 3
 — 4
 — 5
 — 6
 — 7
 — 8
 — 9
 — 10

MACHINE & MODEL:	Colmar T10000FS	REFERENCE:	Dipper Extends by 1000mm
SERIAL No:	8443	DATE OF CHART:	29-May-2019
EQUIPMENT:	4.08m + 2.10m	SAFETY FACTOR:	47.0%
COMMENT:			

Colmar T10000FS
Max Capacity Contours of Radius(m) Plots 2.1m Dipper Cwt In
Level Ground Height 2m Lift BP
Locked Road - Tandem Lift

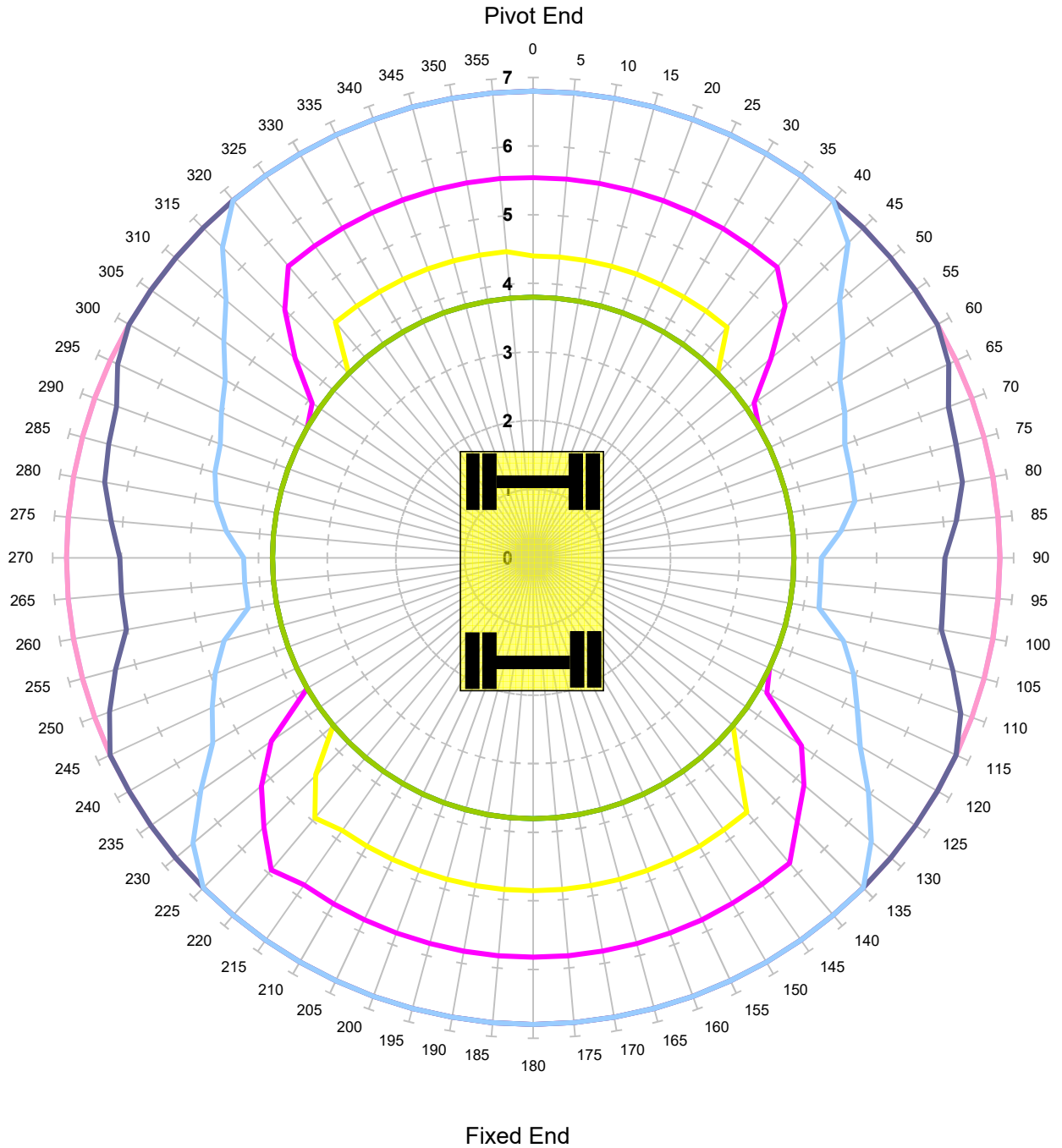

Units in Tonnes

- 1
 — 2
 — 3
 — 4
 — 5
 — 6
 — 7
 — 8
 — 9
 — 10

MACHINE & MODEL:	Colmar T10000FS	REFERENCE:	Dipper Extends by 1000mm
SERIAL No:	8443	DATE OF CHART:	29-May-2019
EQUIPMENT:	4.08m + 2.10m	SAFETY FACTOR:	47.0%
COMMENT:			

Colmar T10000FS
Max Capacity Contours of Radius(m) Plots 3.1m Dipper Cwt In
Gradient 1 in -25 Height 2m Lift BP
Unlocked Rail Cant -150mm

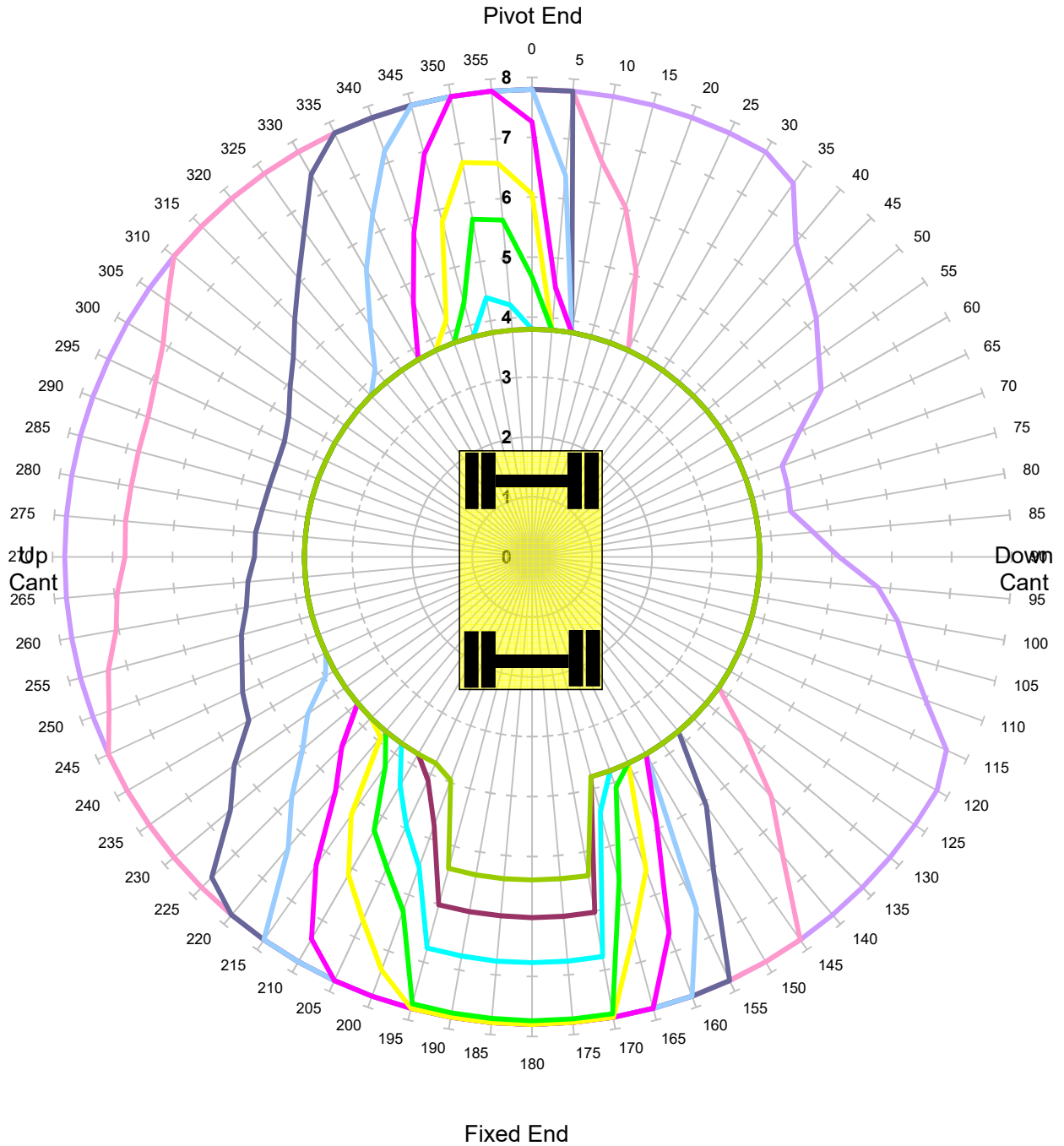

MACHINE & MODEL:	Colmar T10000FS	REFERENCE:	Dipper Extends by 1000mm
SERIAL No:	8443	DATE OF CHART:	29-May-2019
EQUIPMENT:	4.08m + 2.10m	SAFETY FACTOR:	67.0%
COMMENT:			

Colmar T10000FS
Max Capacity Contours of Radius(m) Plots 3.1m Dipper Cwt In
Gradient 1 in -25 Height 2m Lift BP
Unlocked Rail Cant -50mm

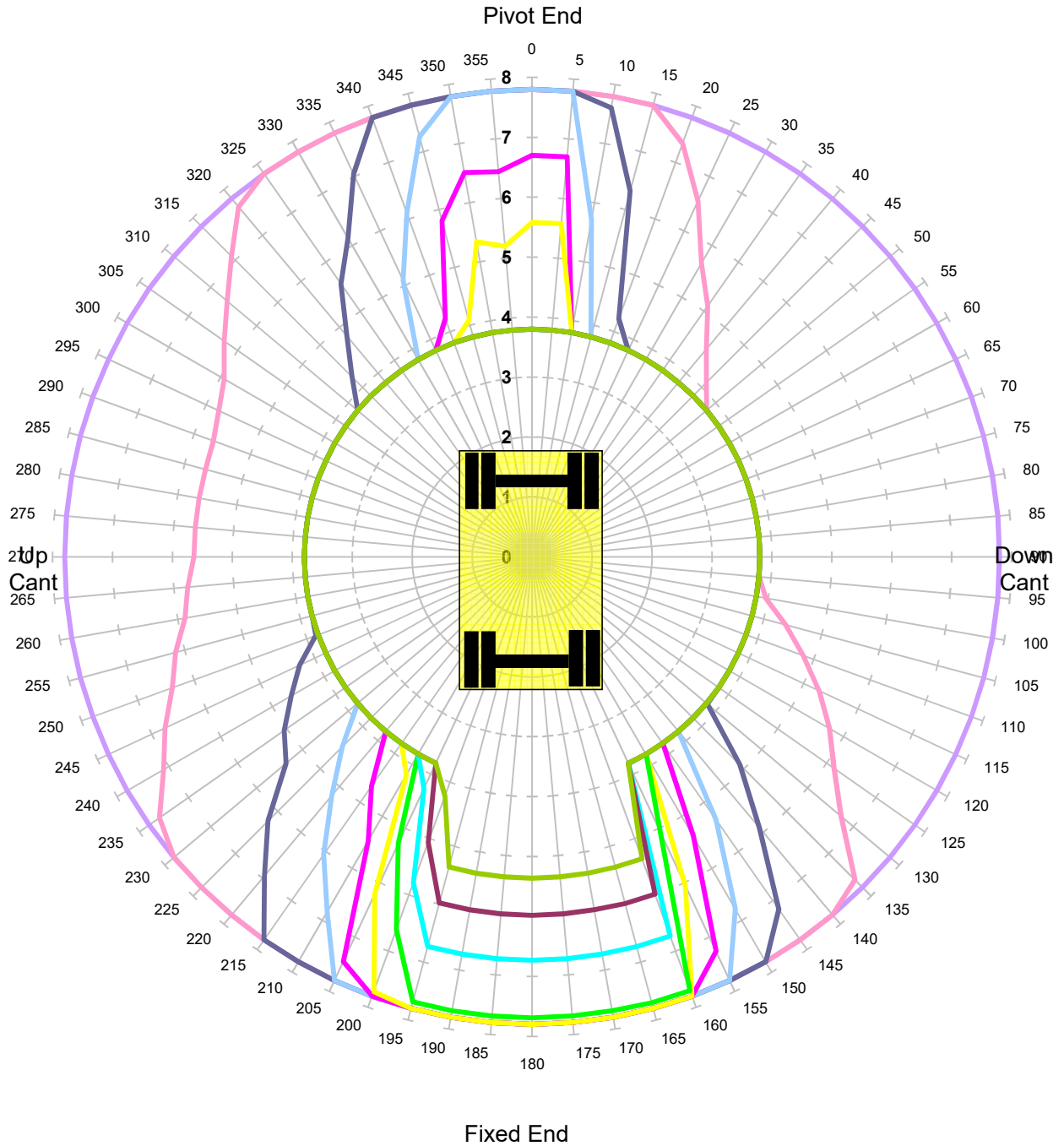

Units in Tonnes
 1 2 3 4 5 6 7 8 9 10

MACHINE & MODEL:	Colmar T10000FS	REFERENCE:	Dipper Extends by 1000mm
SERIAL No:	8443	DATE OF CHART:	29-May-2019
EQUIPMENT:	4.08m + 2.10m	SAFETY FACTOR:	67.0%
COMMENT:			

Colmar T10000FS
Max Capacity Contours of Radius(m) Plots 3.1m Dipper Cwt In
Gradient 1 in -25 Height 2m Lift BP
Unlocked Rail Cant 50mm

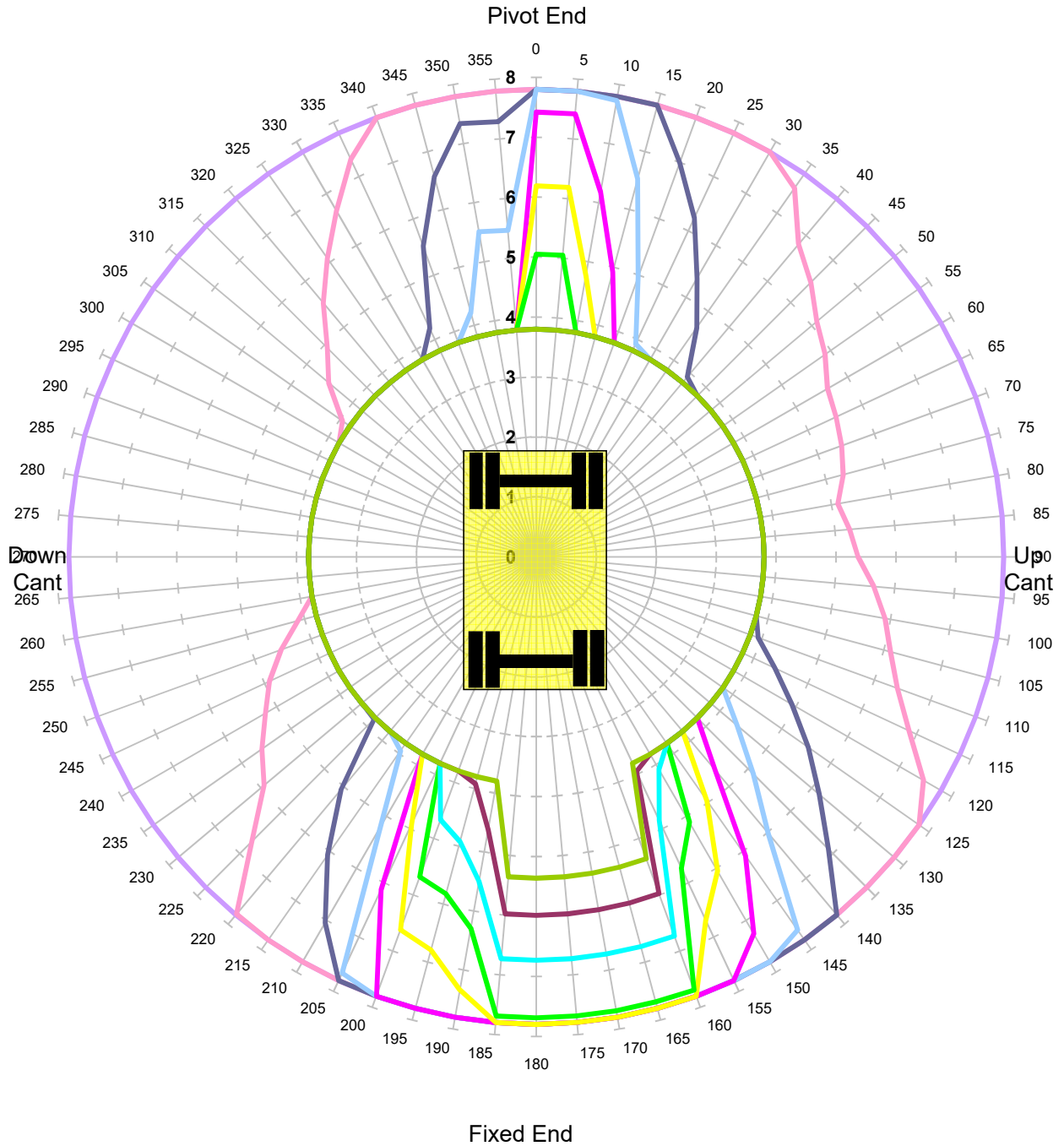

Units in Tonnes

- 1
 — 2
 — 3
 — 4
 — 5
 — 6
 — 7
 — 8
 — 9
 — 10

MACHINE & MODEL:	Colmar T10000FS	REFERENCE:	Dipper Extends by 1000mm
SERIAL No:	8443	DATE OF CHART:	29-May-2019
EQUIPMENT:	4.08m + 2.10m	SAFETY FACTOR:	67.0%
COMMENT:			

Colmar T10000FS
Max Capacity Contours of Radius(m) Plots 3.1m Dipper Cwt In
Gradient 1 in -25 Height 2m Lift BP
Unlocked Rail Cant 150mm

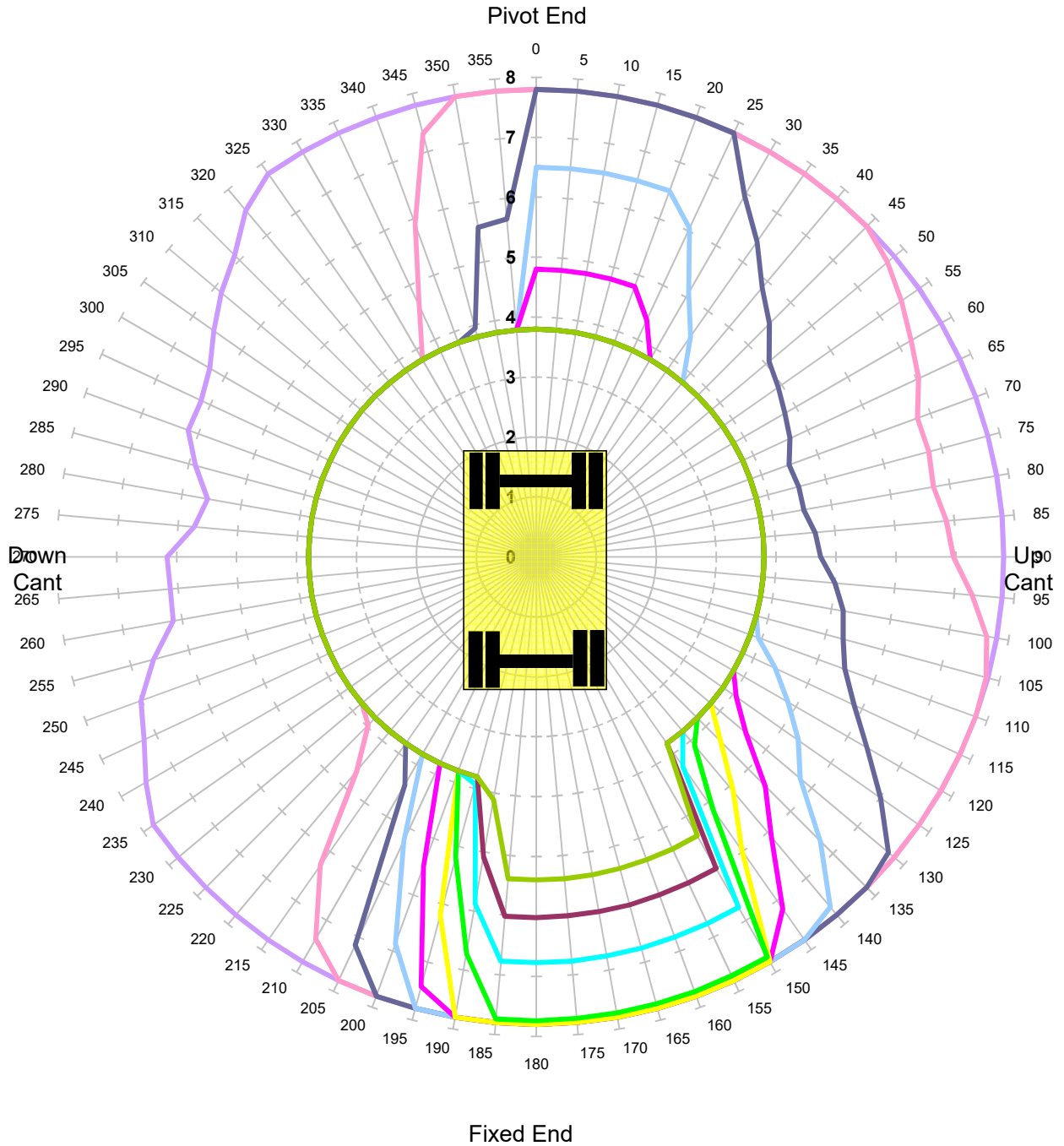

MACHINE & MODEL:	Colmar T10000FS	REFERENCE:	Dipper Extends by 1000mm
SERIAL No:	8443	DATE OF CHART:	29-May-2019
EQUIPMENT:	4.08m + 2.10m	SAFETY FACTOR:	67.0%
COMMENT:			

Colmar T10000FS
Max Capacity Contours of Radius(m) Plots 3.1m Dipper Cwt In
Gradient 1 in -25 Height 2m Lift BP
Locked Rail Cant -150mm

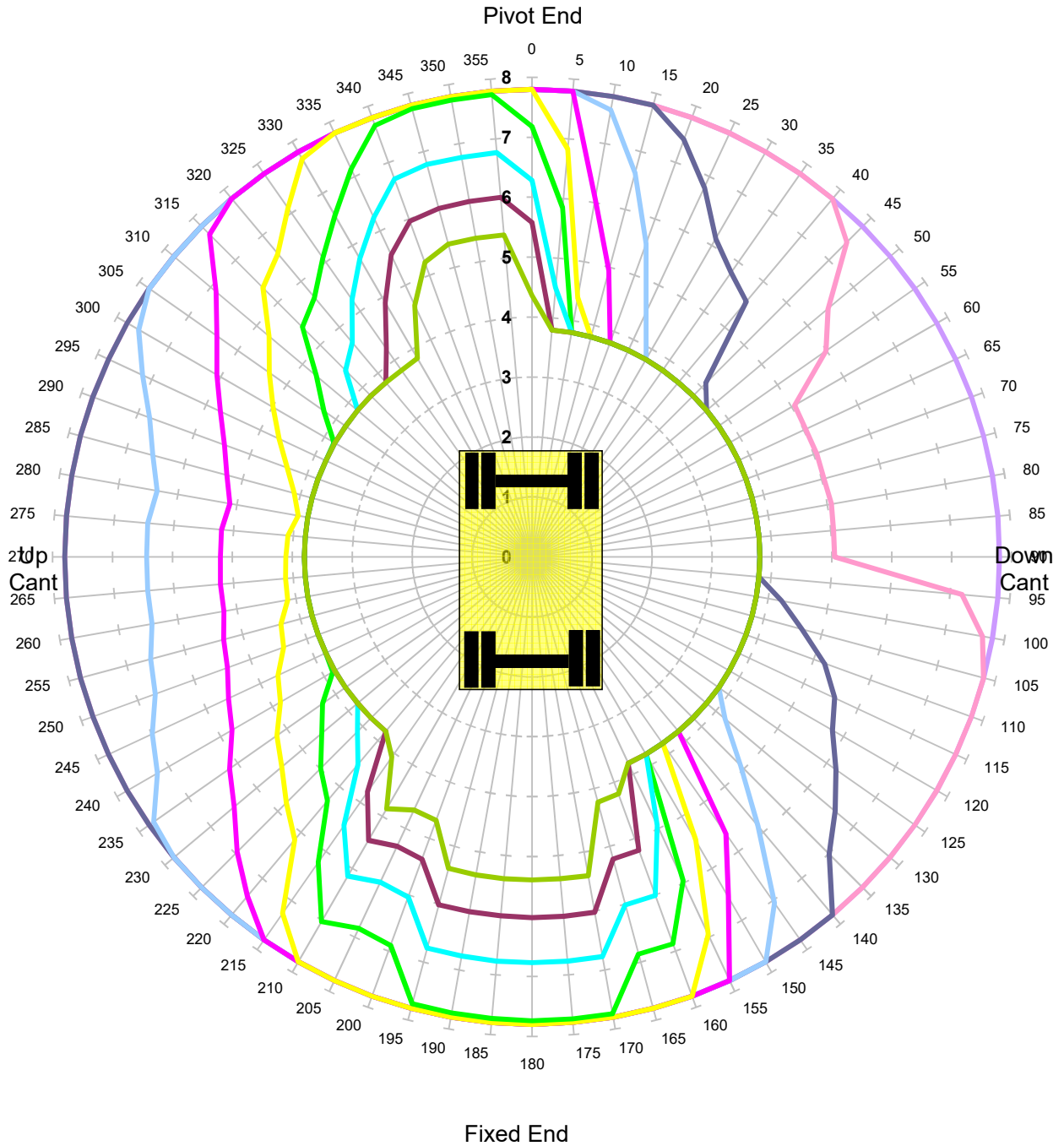

MACHINE & MODEL:	Colmar T10000FS	REFERENCE:	Dipper Extends by 1000mm
SERIAL No:	8443	DATE OF CHART:	29-May-2019
EQUIPMENT:	4.08m + 2.10m	SAFETY FACTOR:	90.0%
COMMENT:			

Colmar T10000FS
Max Capacity Contours of Radius(m) Plots 3.1m Dipper Cwt In
Gradient 1 in -25 Height 2m Lift BP
Locked Rail Cant -50mm

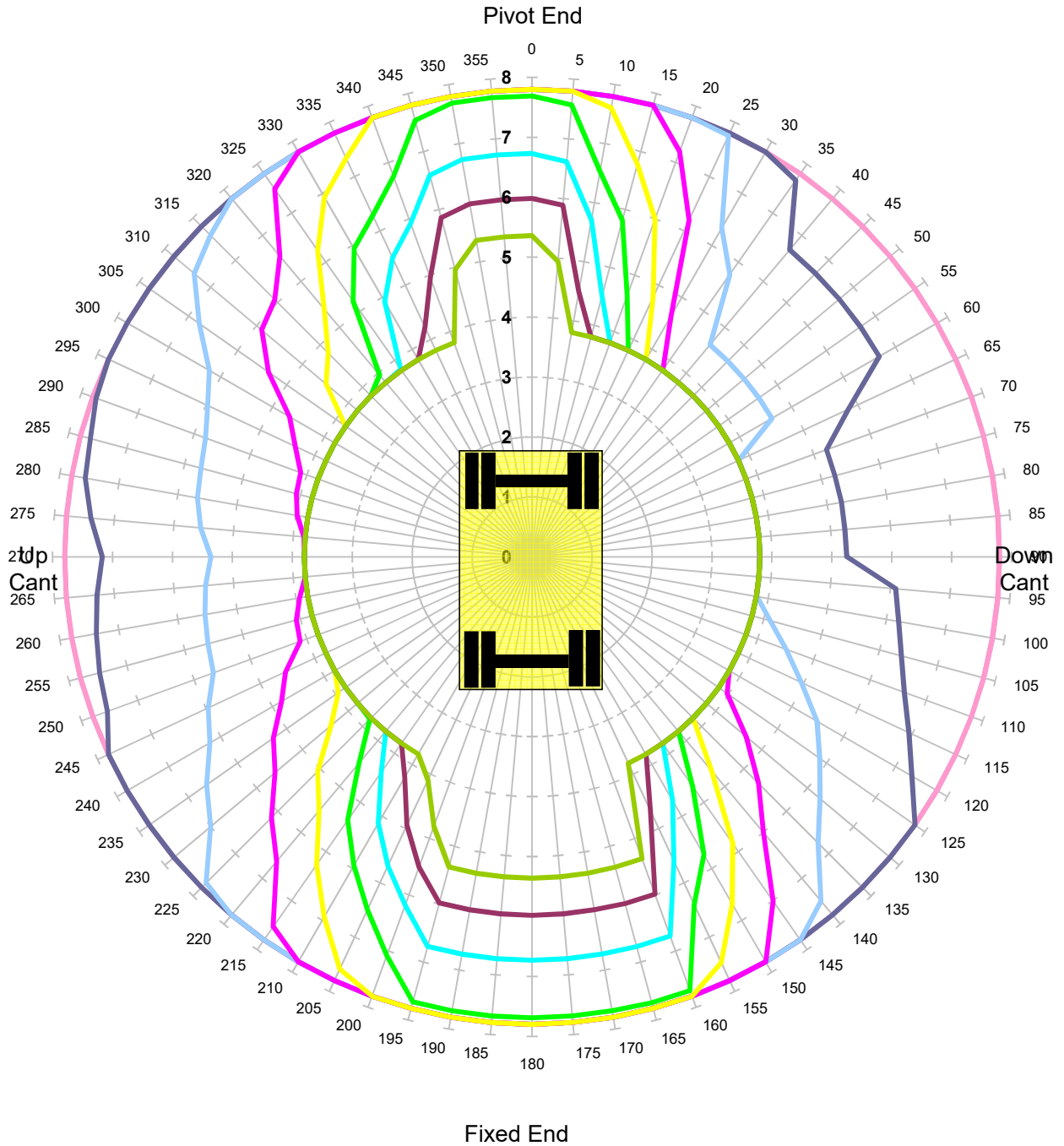

Units in Tonnes

- 1
 — 2
 — 3
 — 4
 — 5
 — 6
 — 7
 — 8
 — 9
 — 10

MACHINE & MODEL:	Colmar T10000FS	REFERENCE:	Dipper Extends by 1000mm
SERIAL No:	8443	DATE OF CHART:	29-May-2019
EQUIPMENT:	4.08m + 2.10m	SAFETY FACTOR:	90.0%
COMMENT:			

Colmar T10000FS
Max Capacity Contours of Radius(m) Plots 3.1m Dipper Cwt In
Gradient 1 in -25 Height 2m Lift BP
Locked Rail Cant 50mm

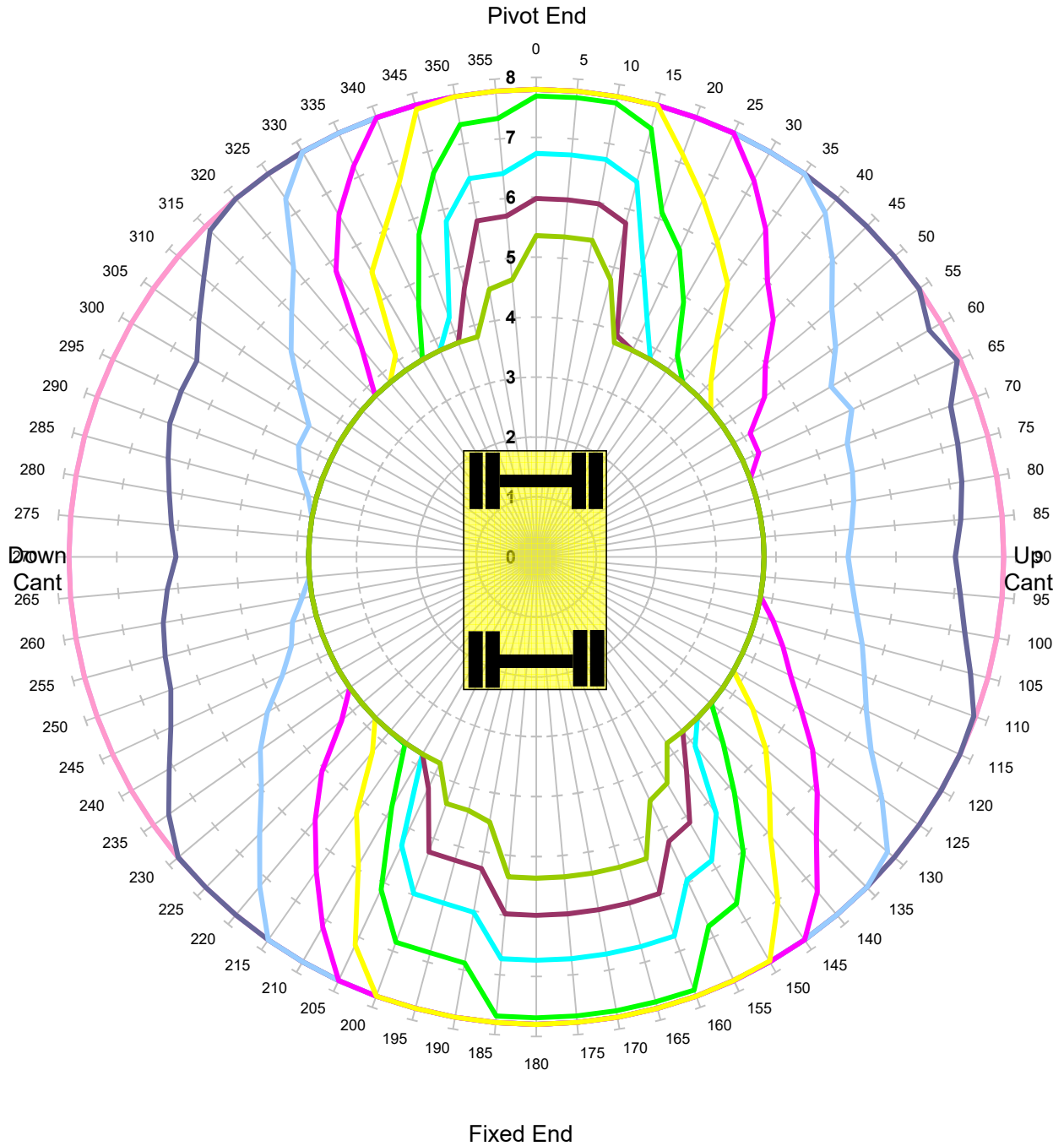

MACHINE & MODEL:	Colmar T10000FS	REFERENCE:	Dipper Extends by 1000mm
SERIAL No:	8443	DATE OF CHART:	29-May-2019
EQUIPMENT:	4.08m + 2.10m	SAFETY FACTOR:	90.0%
COMMENT:			

Colmar T10000FS
Max Capacity Contours of Radius(m) Plots 3.1m Dipper Cwt In
Gradient 1 in -25 Height 2m Lift BP
Locked Rail Cant 150mm

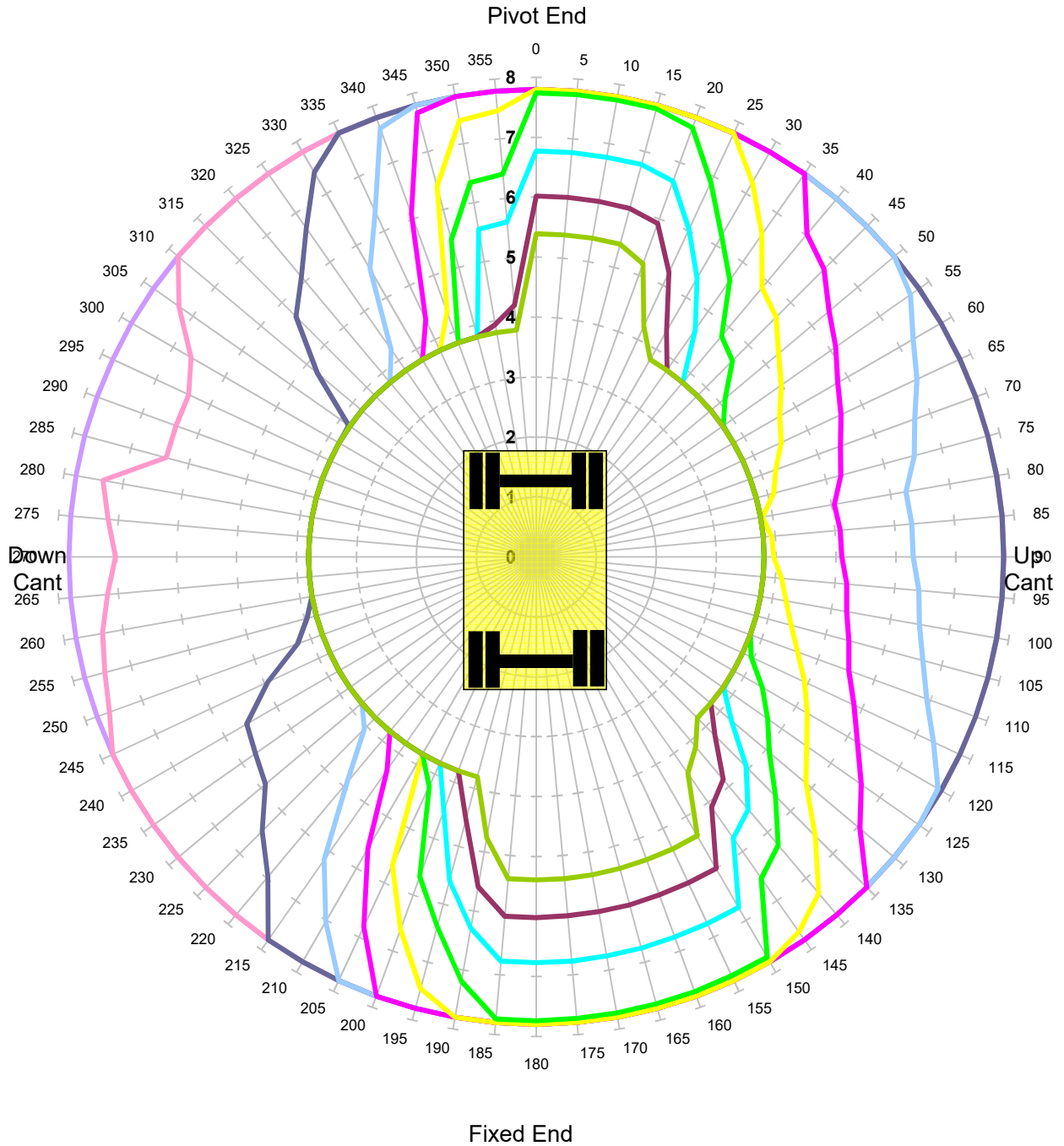

Units in Tonnes

- 1
 — 2
 — 3
 — 4
 — 5
 — 6
 — 7
 — 8
 — 9
 — 10

MACHINE & MODEL:	Colmar T10000FS	REFERENCE:	Dipper Extends by 1000mm
SERIAL No:	8443	DATE OF CHART:	29-May-2019
EQUIPMENT:	4.08m + 2.10m	SAFETY FACTOR:	90.0%
COMMENT:			

Colmar T10000FS
Max Capacity Contours of Radius(m) Plots 3.1m Dipper Cwt In
Level Ground Height 2m Lift BP
Unlocked Road

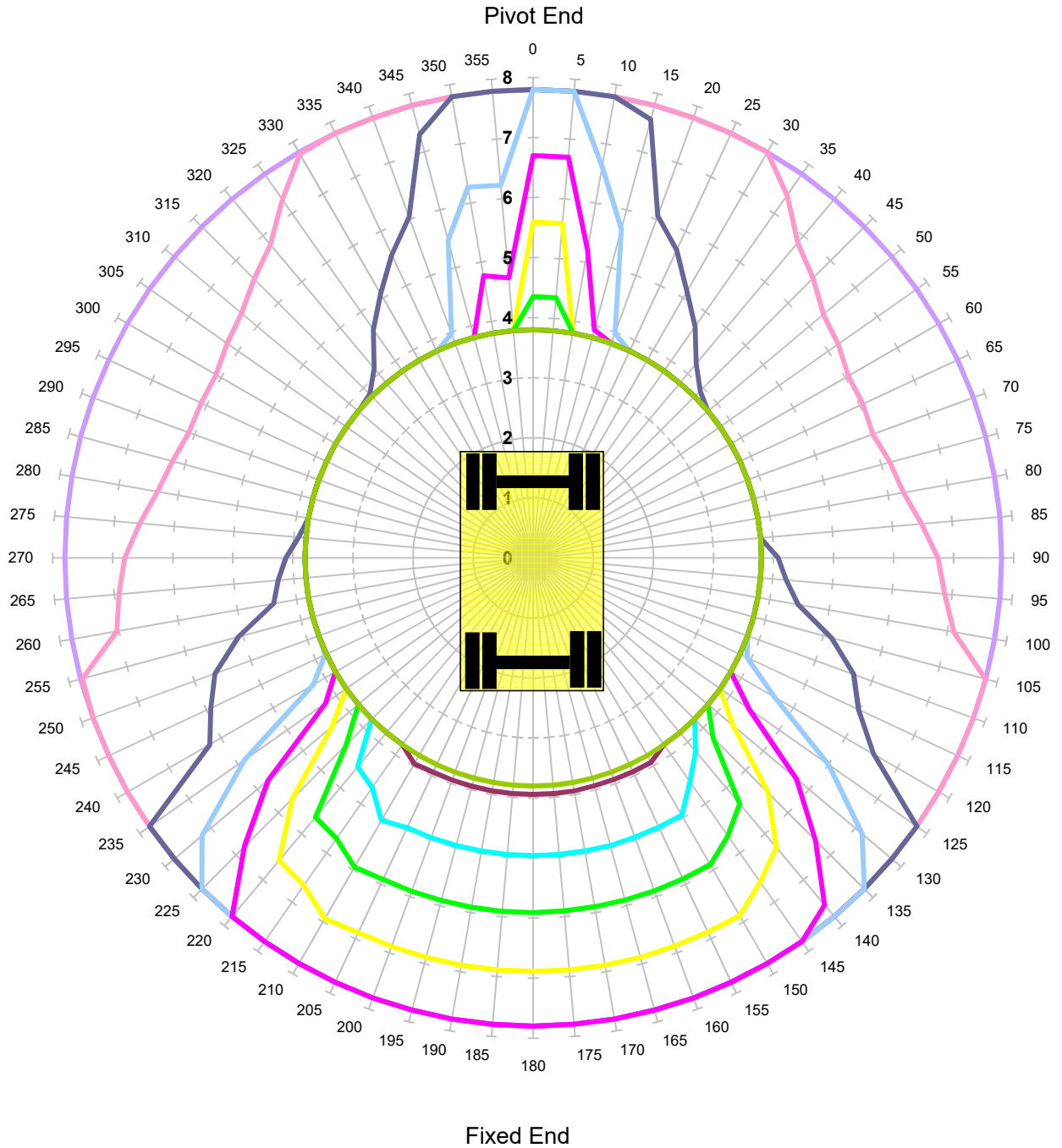

Units in Tonnes

- 1
 — 2
 — 3
 — 4
 — 5
 — 6
 — 7
 — 8
 — 9
 — 10

MACHINE & MODEL:	Colmar T10000FS	REFERENCE:	Dipper Extends by 1000mm
SERIAL No:	8443	DATE OF CHART:	29-May-2019
EQUIPMENT:	4.08m + 2.10m	SAFETY FACTOR:	71.0%
COMMENT:			

Colmar T10000FS
Max Capacity Contours of Radius(m) Plots 3.1m Dipper Cwt In
Level Ground Height 2m Lift BP
Locked Road

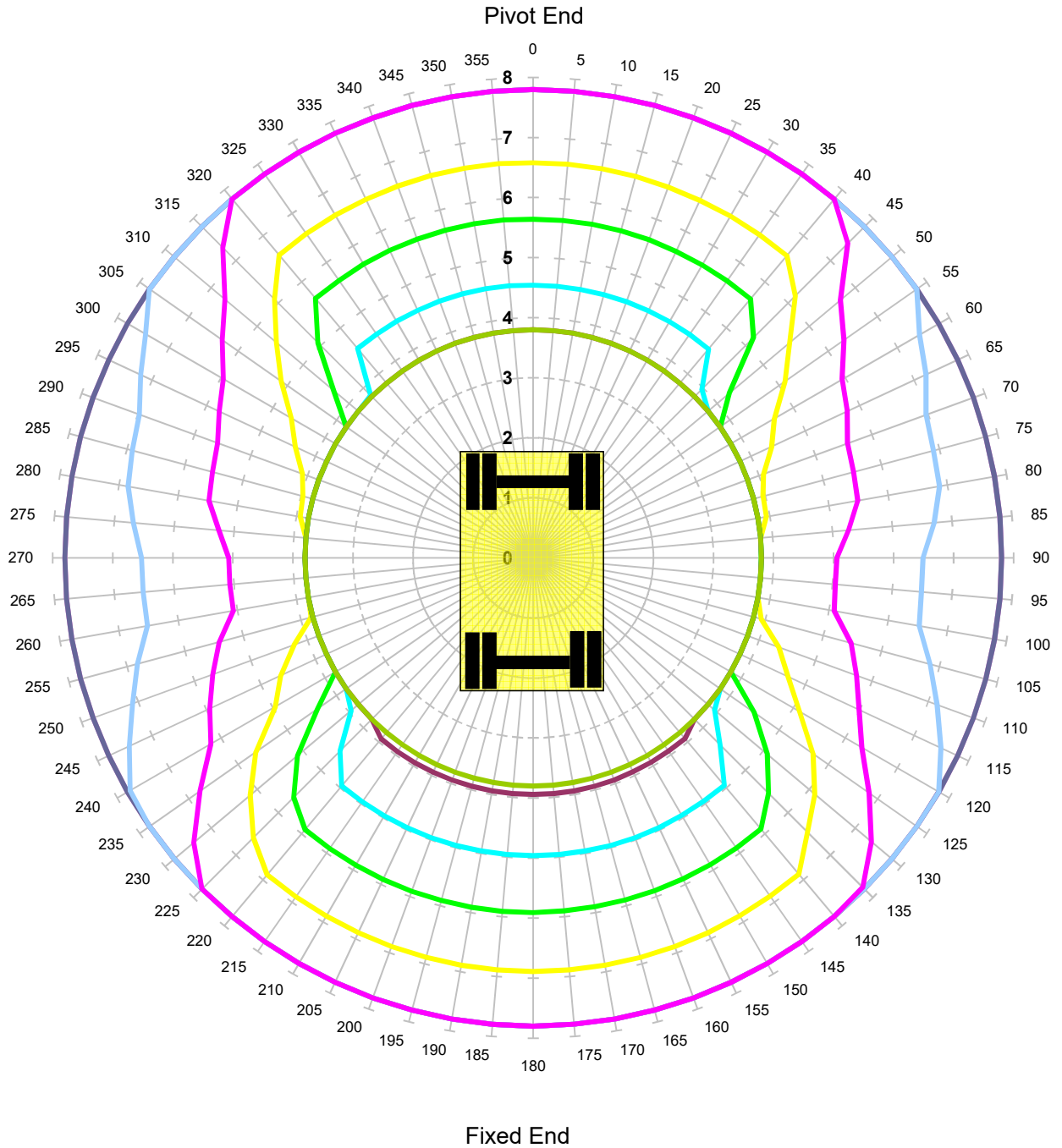

Units in Tonnes

- 1
- 2
- 3
- 4
- 5
- 6
- 7
- 8
- 9
- 10

MACHINE & MODEL:	Colmar T10000FS	REFERENCE:	Dipper Extends by 1000mm
SERIAL No:	8443	DATE OF CHART:	29-May-2019
EQUIPMENT:	4.08m + 2.10m	SAFETY FACTOR:	71.0%
COMMENT:			

Colmar T10000FS

**Max Capacity Contours of Radius(m) Plots 3.1m Dipper Cwt In
Gradient 1 in -25 Height 2m Lift BP**

Unlocked Rail Cant -150mm - Tandem Lift

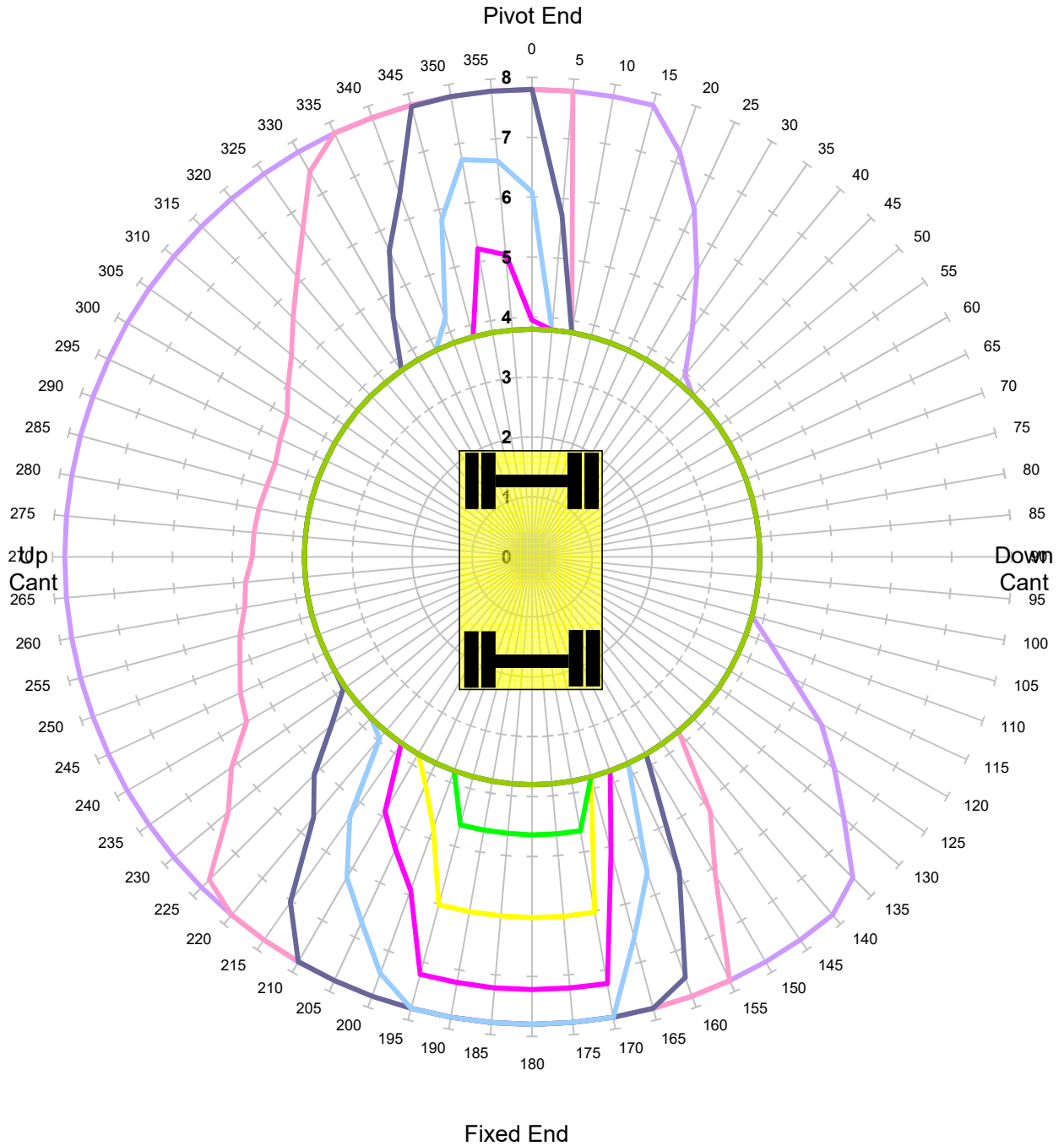

Units in Tonnes

- 1
 — 2
 — 3
 — 4
 — 5
 — 6
 — 7
 — 8
 — 9
 — 10

MACHINE & MODEL:	Colmar T10000FS	REFERENCE:	Dipper Extends by 1000mm
SERIAL No:	8443	DATE OF CHART:	29-May-2019
EQUIPMENT:	4.08m + 2.10m	SAFETY FACTOR:	45.0%
COMMENT:			

Colmar T10000FS

**Max Capacity Contours of Radius(m) Plots 3.1m Dipper Cwt In
Gradient 1 in -25 Height 2m Lift BP**

Unlocked Rail Cant -50mm - Tandem Lift

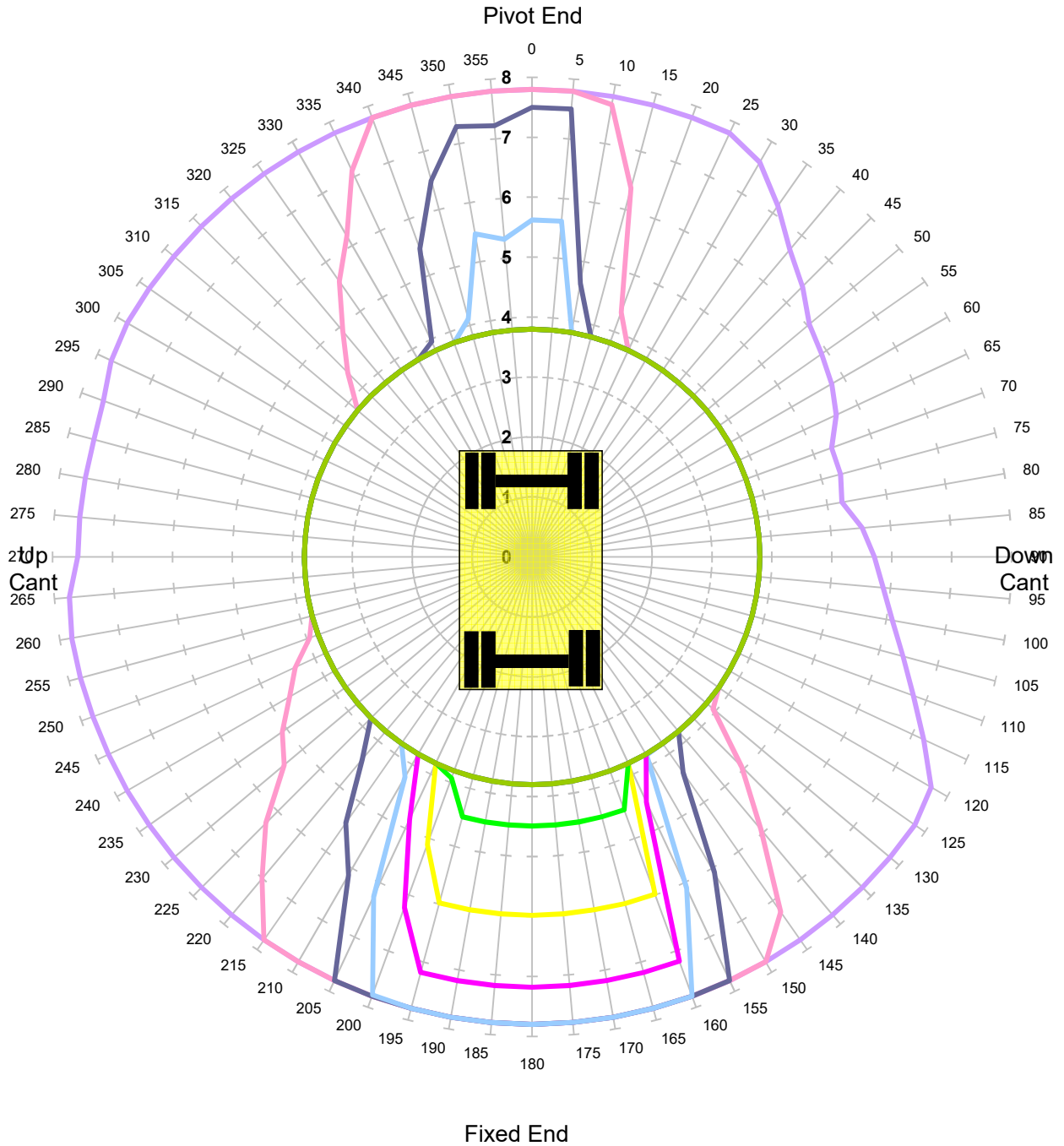

Units in Tonnes

- 1
 — 2
 — 3
 — 4
 — 5
 — 6
 — 7
 — 8
 — 9
 — 10

MACHINE & MODEL:	Colmar T10000FS	REFERENCE:	Dipper Extends by 1000mm
SERIAL No:	8443	DATE OF CHART:	29-May-2019
EQUIPMENT:	4.08m + 2.10m	SAFETY FACTOR:	45.0%
COMMENT:			

Colmar T10000FS

**Max Capacity Contours of Radius(m) Plots 3.1m Dipper Cwt In
Gradient 1 in -25 Height 2m Lift BP**

Unlocked Rail Cant 50mm - Tandem Lift

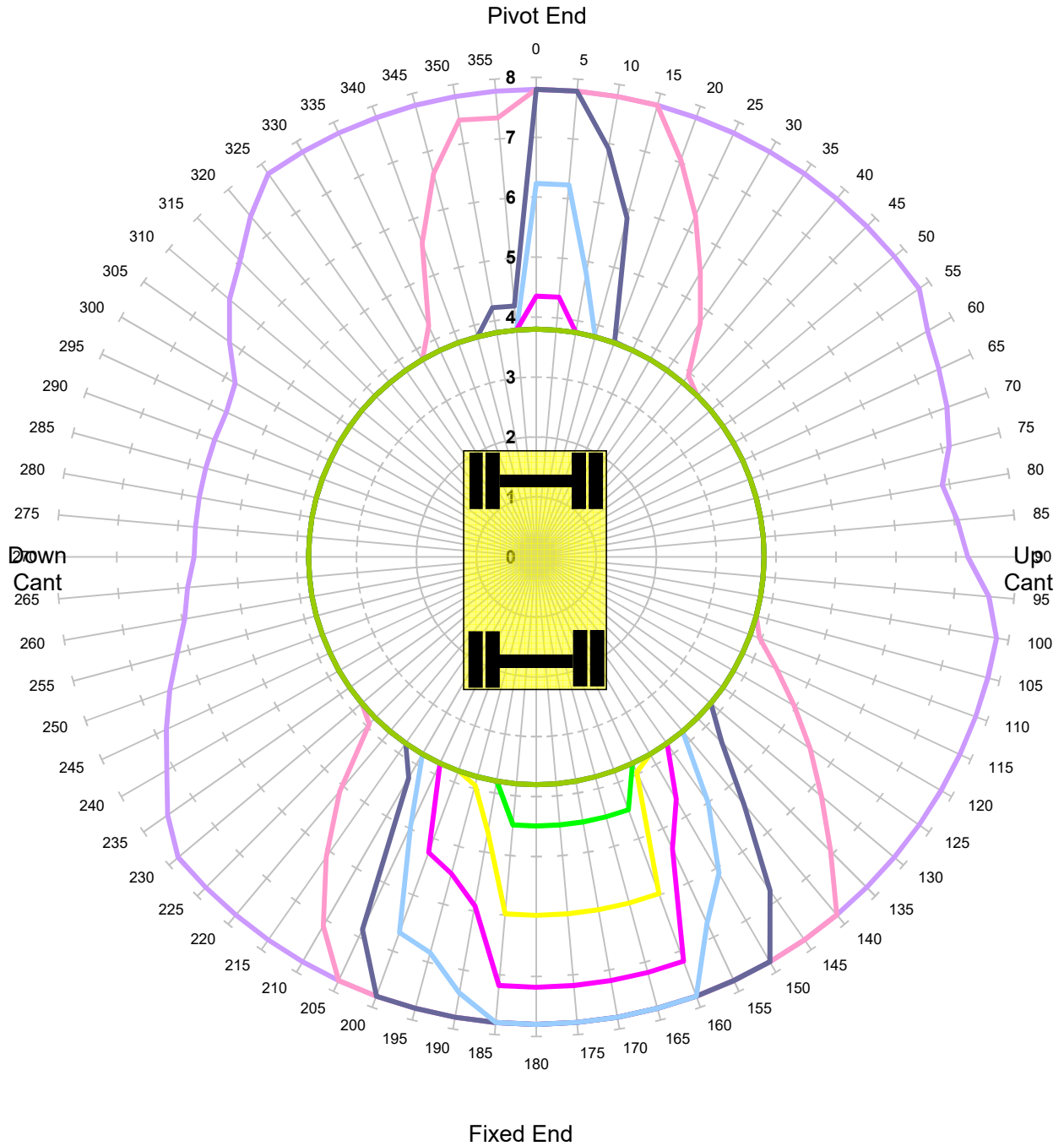

Units in Tonnes

- 1
 — 2
 — 3
 — 4
 — 5
 — 6
 — 7
 — 8
 — 9
 — 10

MACHINE & MODEL:	Colmar T10000FS	REFERENCE:	Dipper Extends by 1000mm
SERIAL No:	8443	DATE OF CHART:	29-May-2019
EQUIPMENT:	4.08m + 2.10m	SAFETY FACTOR:	45.0%
COMMENT:			

Colmar T10000FS

**Max Capacity Contours of Radius(m) Plots 3.1m Dipper Cwt In
Gradient 1 in -25 Height 2m Lift BP**

Unlocked Rail Cant 150mm - Tandem Lift

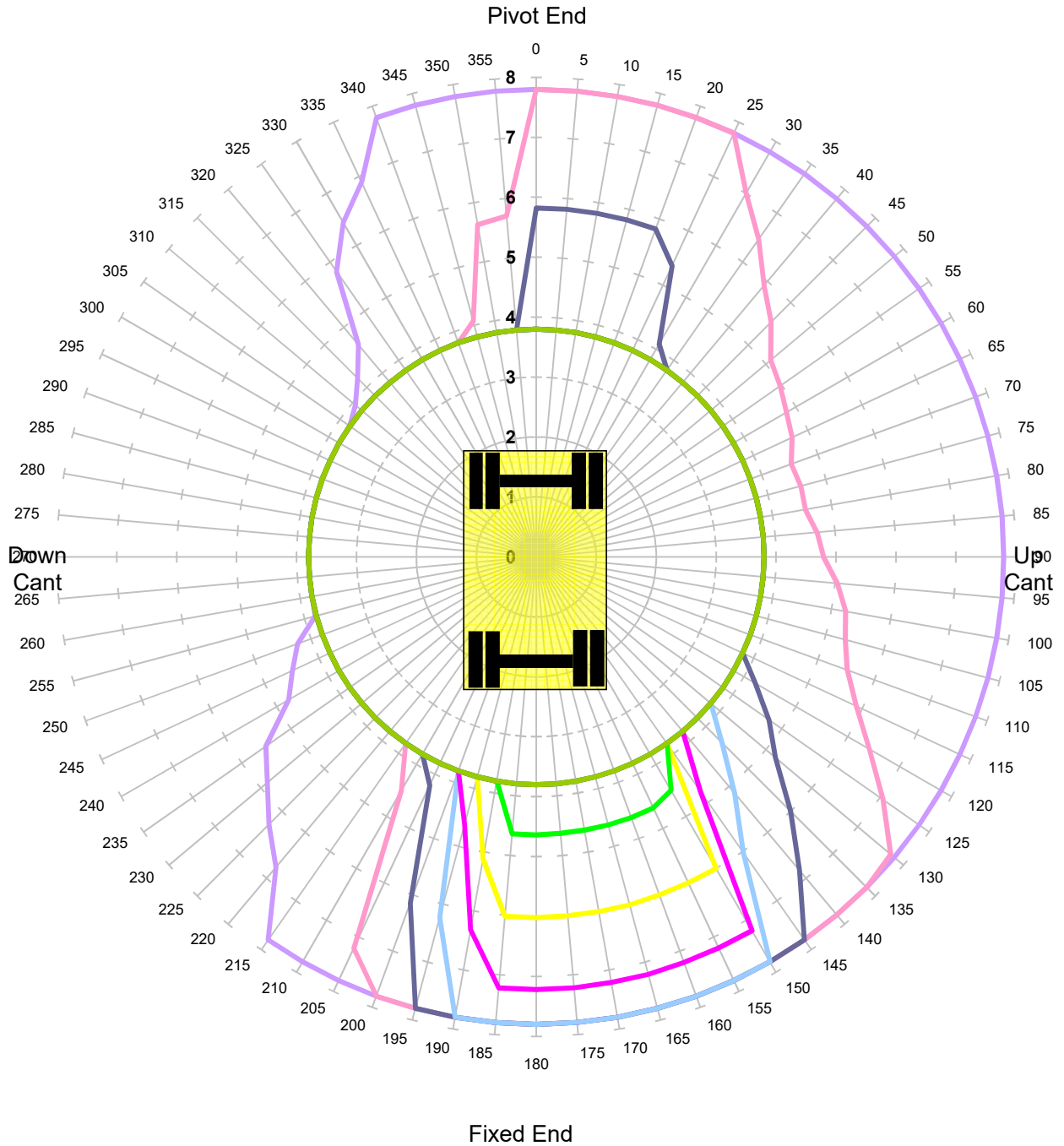

Units in Tonnes

- 1
 — 2
 — 3
 — 4
 — 5
 — 6
 — 7
 — 8
 — 9
 — 10

MACHINE & MODEL:	Colmar T10000FS	REFERENCE:	Dipper Extends by 1000mm
SERIAL No:	8443	DATE OF CHART:	29-May-2019
EQUIPMENT:	4.08m + 2.10m	SAFETY FACTOR:	45.0%
COMMENT:			

Colmar T10000FS

**Max Capacity Contours of Radius(m) Plots 3.1m Dipper Cwt In
Gradient 1 in -25 Height 2m Lift BP**

Locked Rail Cant -150mm - Tandem Lift

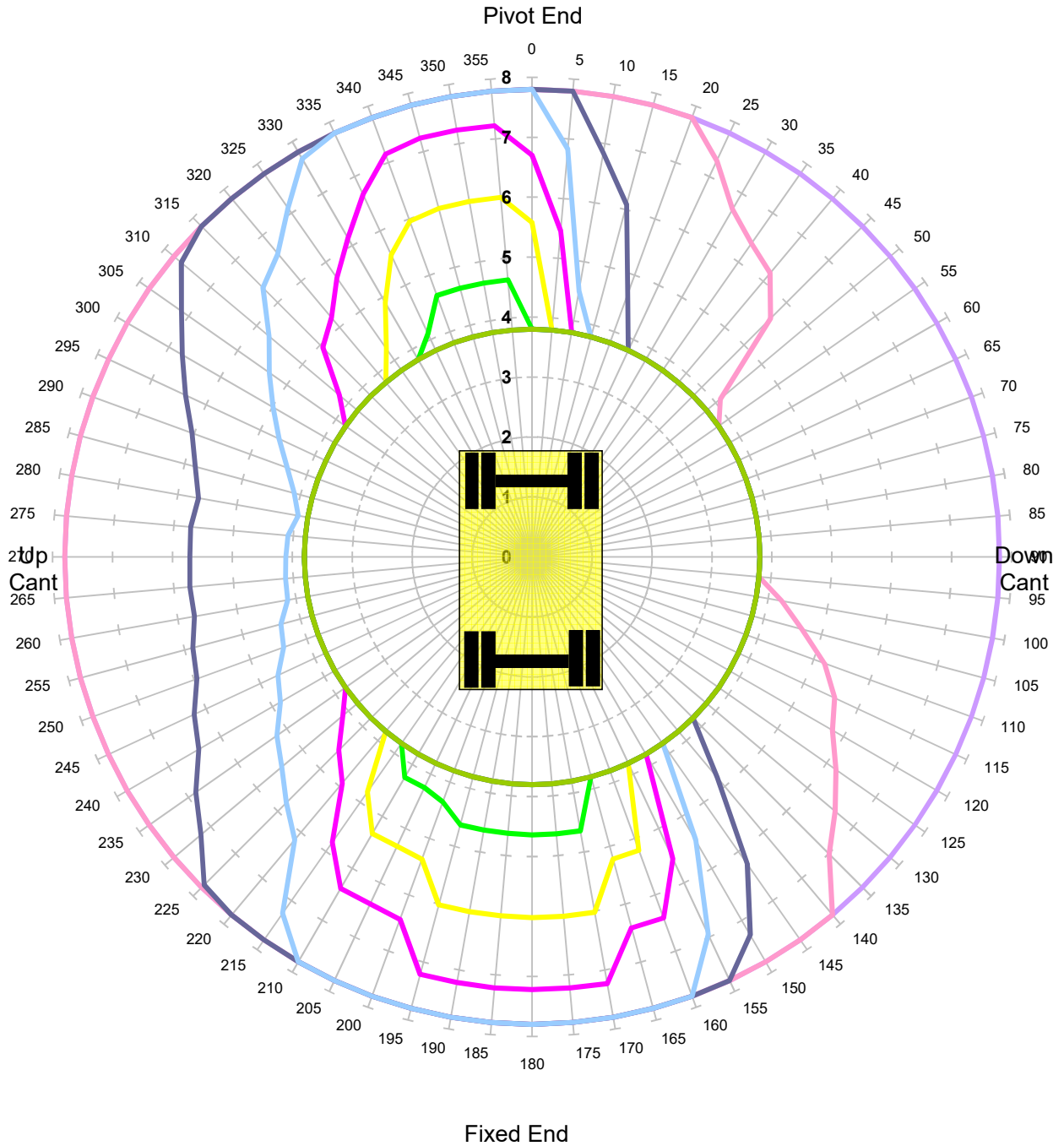

Units in Tonnes

- 1
- 2
- 3
- 4
- 5
- 6
- 7
- 8
- 9
- 10

MACHINE & MODEL:	Colmar T10000FS	REFERENCE:	Dipper Extends by 1000mm
SERIAL No:	8443	DATE OF CHART:	29-May-2019
EQUIPMENT:	4.08m + 2.10m	SAFETY FACTOR:	60.0%
COMMENT:			

Colmar T10000FS

**Max Capacity Contours of Radius(m) Plots 3.1m Dipper Cwt In
Gradient 1 in -25 Height 2m Lift BP**

Locked Rail Cant -50mm - Tandem Lift

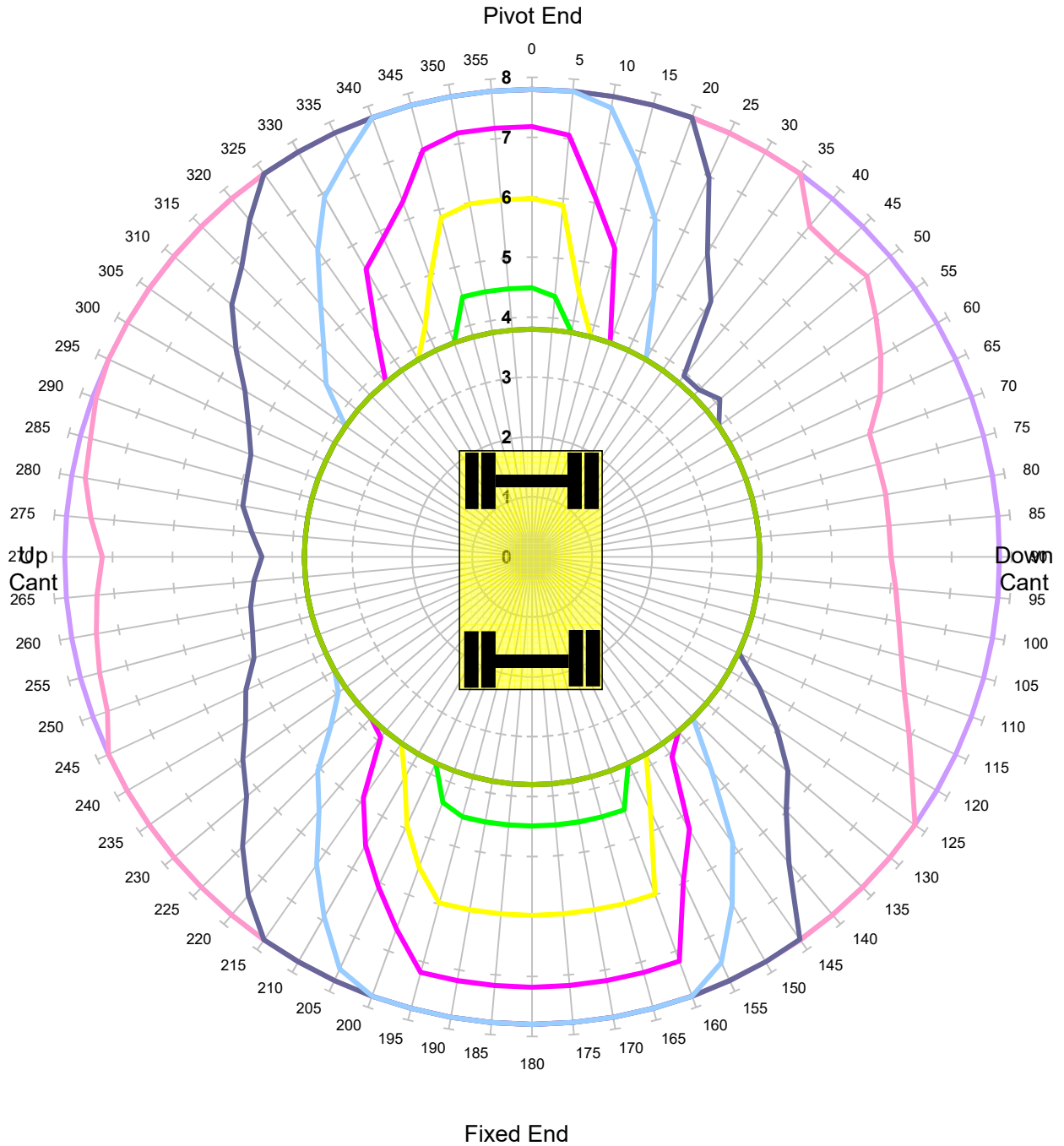

Units in Tonnes

- 1
 — 2
 — 3
 — 4
 — 5
 — 6
 — 7
 — 8
 — 9
 — 10

MACHINE & MODEL:	Colmar T10000FS	REFERENCE:	Dipper Extends by 1000mm
SERIAL No:	8443	DATE OF CHART:	29-May-2019
EQUIPMENT:	4.08m + 2.10m	SAFETY FACTOR:	60.0%
COMMENT:			

Colmar T10000FS

**Max Capacity Contours of Radius(m) Plots 3.1m Dipper Cwt In
Gradient 1 in -25 Height 2m Lift BP**

Locked Rail Cant 50mm - Tandem Lift

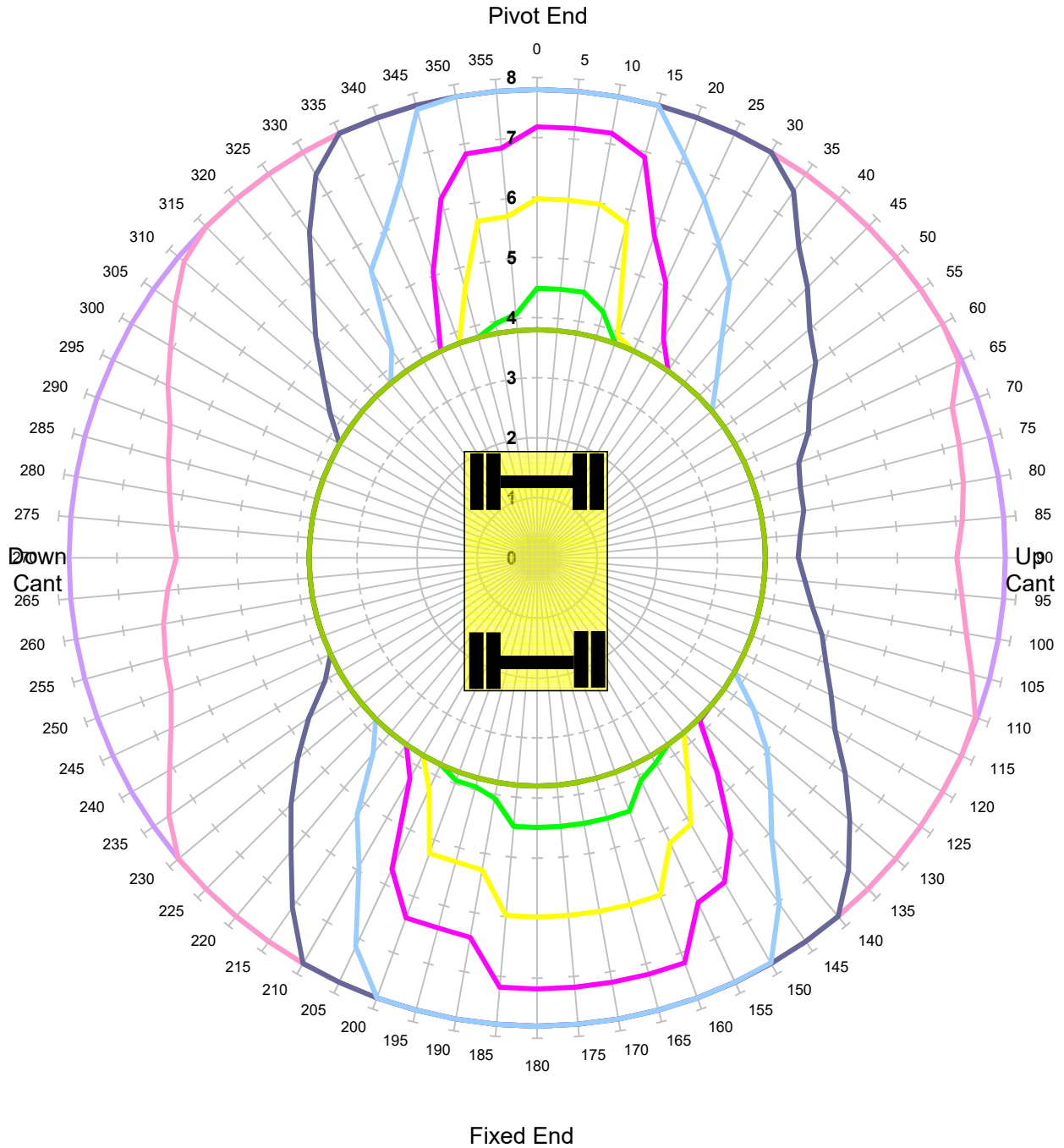

MACHINE & MODEL:	Colmar T10000FS	REFERENCE:	Dipper Extends by 1000mm
SERIAL No:	8443	DATE OF CHART:	29-May-2019
EQUIPMENT:	4.08m + 2.10m	SAFETY FACTOR:	60.0%
COMMENT:			

Colmar T10000FS

**Max Capacity Contours of Radius(m) Plots 3.1m Dipper Cwt In
Gradient 1 in -25 Height 2m Lift BP**

Locked Rail Cant 150mm - Tandem Lift

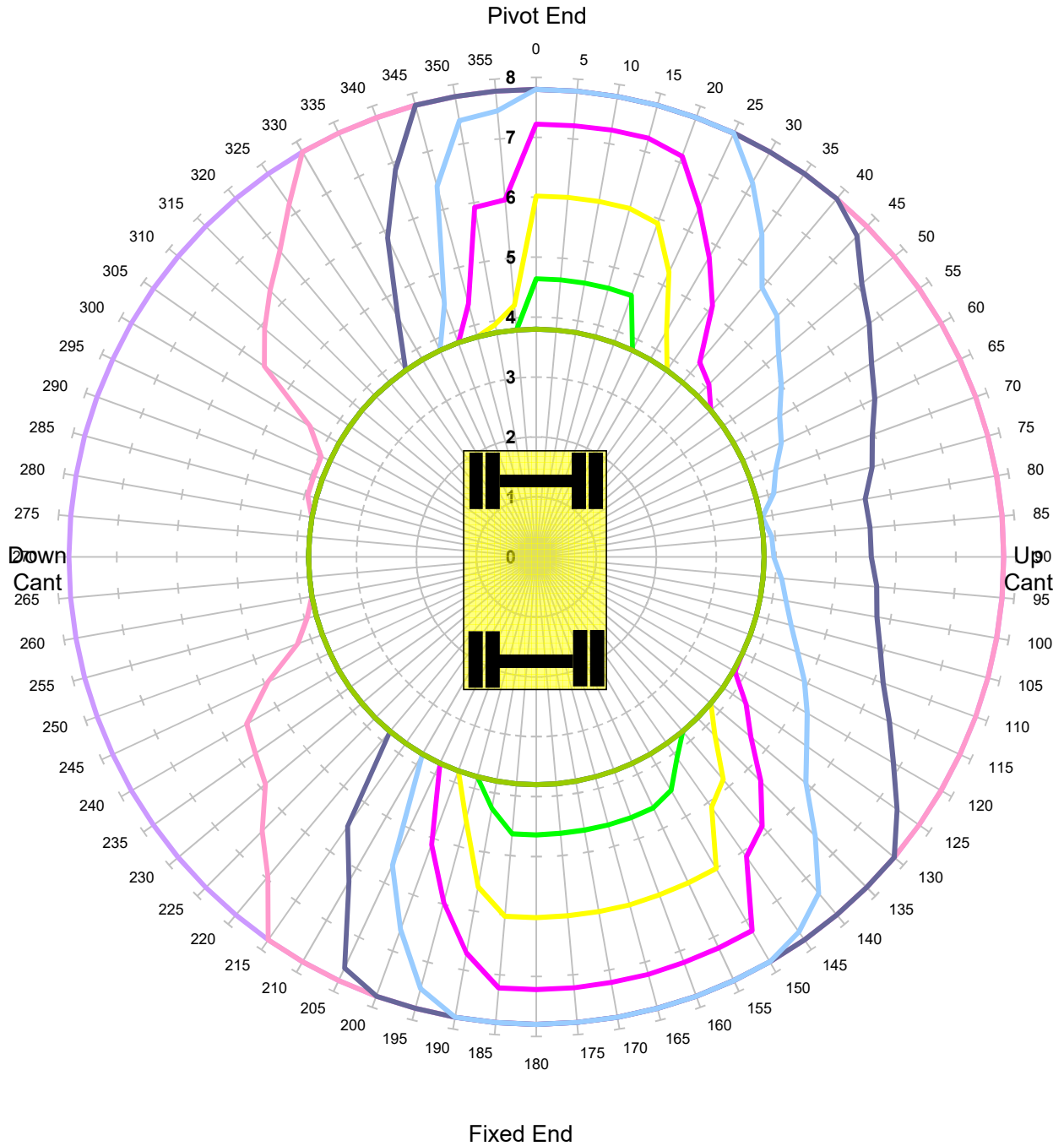

Units in Tonnes

- 1
- 2
- 3
- 4
- 5
- 6
- 7
- 8
- 9
- 10

MACHINE & MODEL:	Colmar T10000FS	REFERENCE:	Dipper Extends by 1000mm
SERIAL No:	8443	DATE OF CHART:	29-May-2019
EQUIPMENT:	4.08m + 2.10m	SAFETY FACTOR:	60.0%
COMMENT:			

Colmar T1000FS
Max Capacity Contours of Radius(m) Plots 3.1m Dipper Cwt In
Level Ground Height 2m Lift BP
Unlocked Road - Tandem Lift

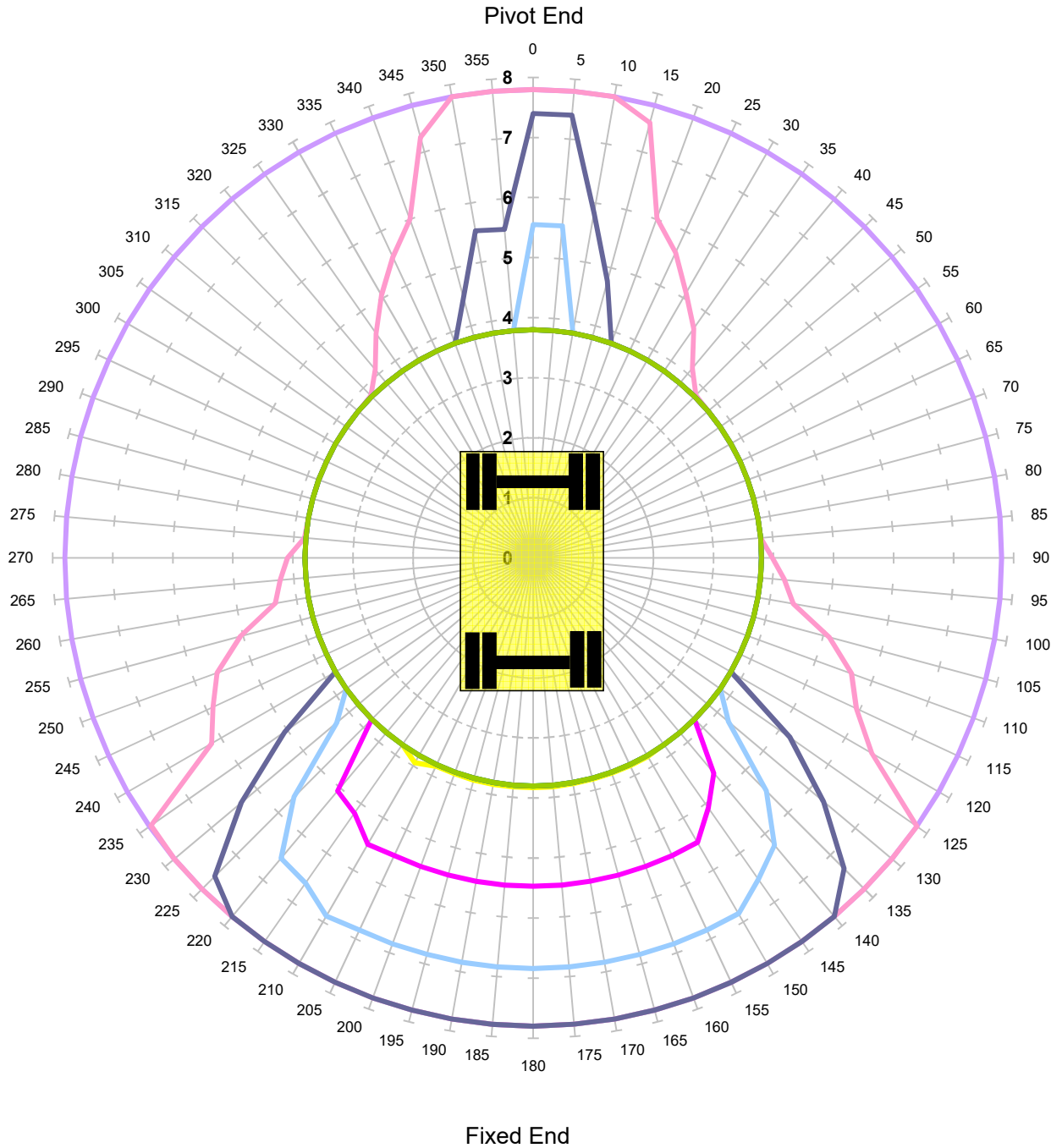

Units in Tonnes

- 1
 — 2
 — 3
 — 4
 — 5
 — 6
 — 7
 — 8
 — 9
 — 10

MACHINE & MODEL:	Colmar T1000FS	REFERENCE:	Dipper Extends by 1000mm
SERIAL No:	8443	DATE OF CHART:	29-May-2019
EQUIPMENT:	4.08m + 2.10m	SAFETY FACTOR:	47.0%
COMMENT:			

Colmar T10000FS
Max Capacity Contours of Radius(m) Plots 3.1m Dipper Cwt In
Level Ground Height 2m Lift BP
Locked Road - Tandem Lift

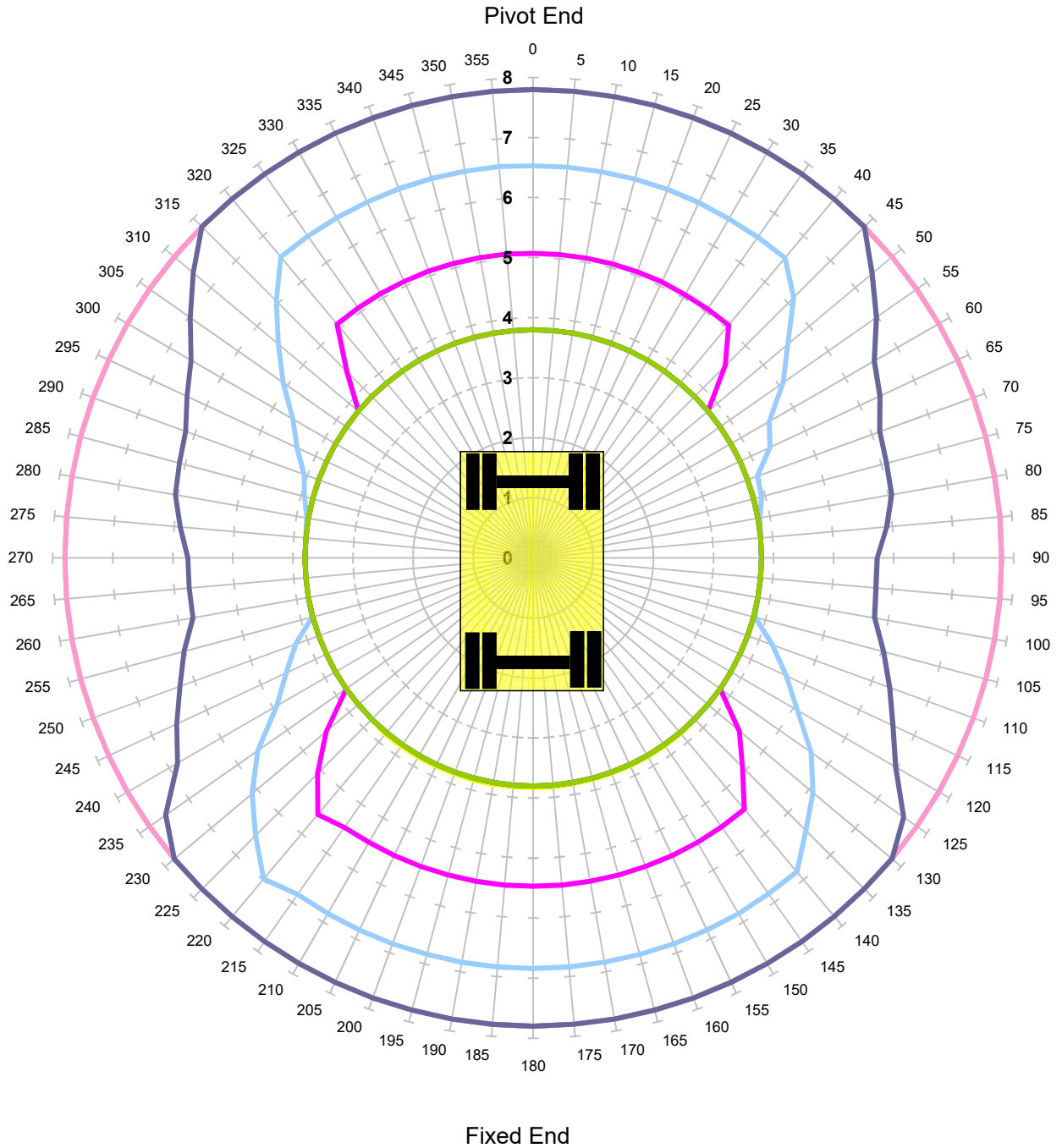

Units in Tonnes

- 1
- 2
- 3
- 4
- 5
- 6
- 7
- 8
- 9
- 10

MACHINE & MODEL:	Colmar T10000FS	REFERENCE:	Dipper Extends by 1000mm
SERIAL No:	8443	DATE OF CHART:	29-May-2019
EQUIPMENT:	4.08m + 2.10m	SAFETY FACTOR:	47.0%
COMMENT:			

Colmar T10000FS
Max Capacity Contours of Radius(m) Plots 2.1m Dipper Cwt Out
Gradient 1 in -25 Height 2m Lift BP
Unlocked Rail Cant -150mm

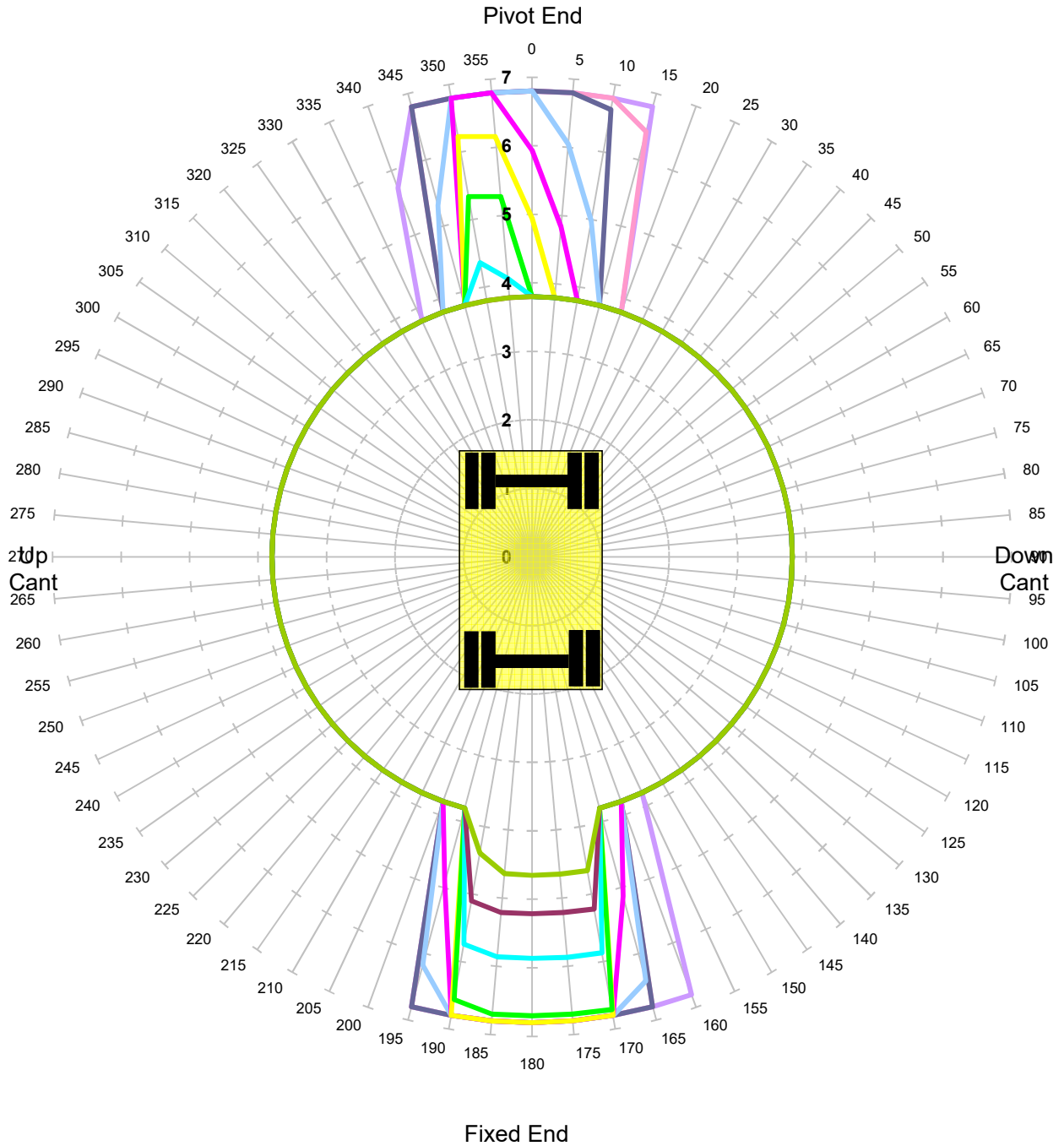

Units in Tonnes

- 1
- 2
- 3
- 4
- 5
- 6
- 7
- 8
- 9
- 10

MACHINE & MODEL:	Colmar T10000FS	REFERENCE:	Dipper Extends by 1000mm
SERIAL No:	8443	DATE OF CHART:	29-May-2019
EQUIPMENT:	4.08m + 2.10m	SAFETY FACTOR:	67.0%
COMMENT:			

Colmar T10000FS
Max Capacity Contours of Radius(m) Plots 2.1m Dipper Cwt Out
Gradient 1 in -25 Height 2m Lift BP
Unlocked Rail Cant -50mm

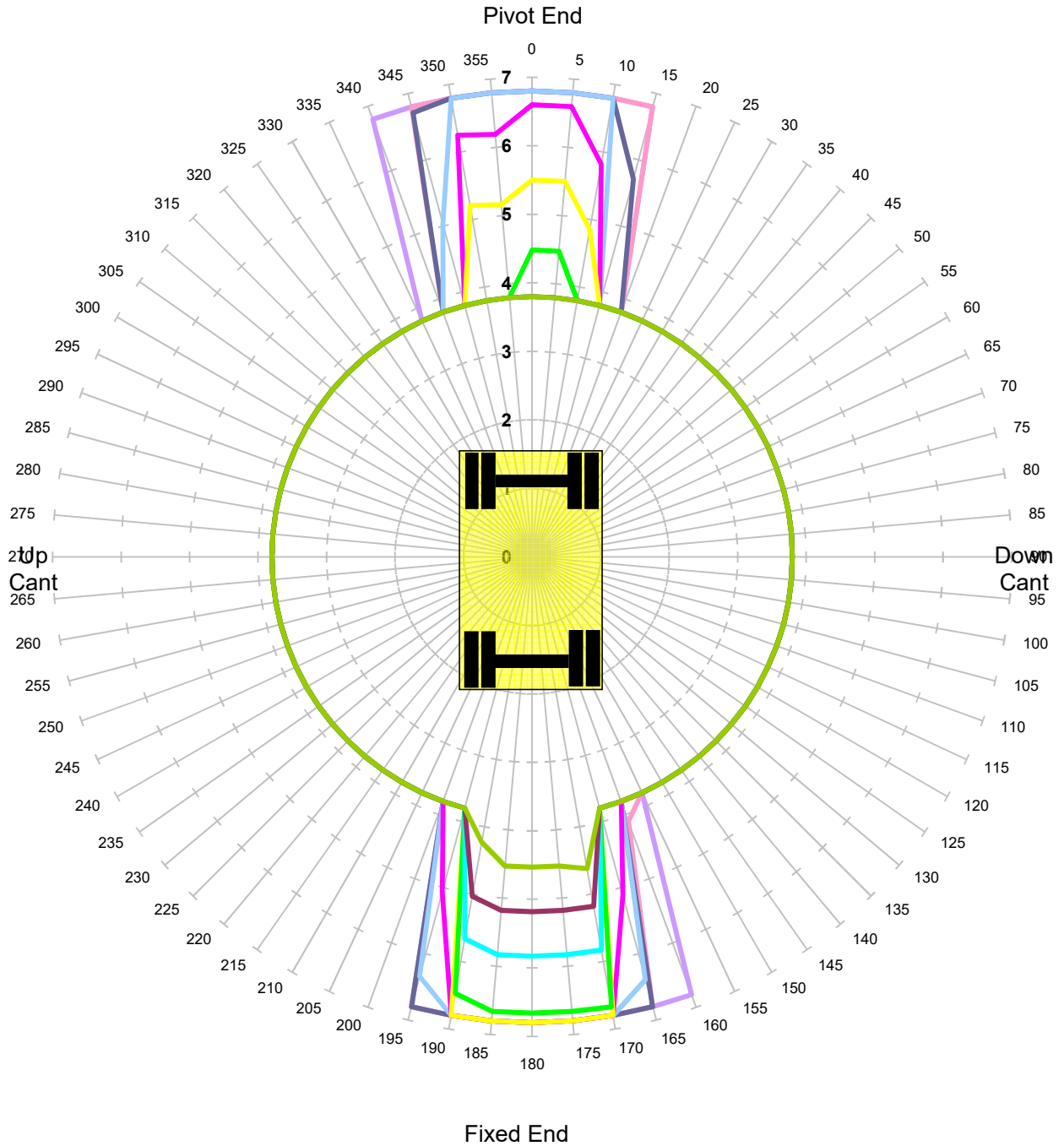

Units in Tonnes

- 1
- 2
- 3
- 4
- 5
- 6
- 7
- 8
- 9
- 10

MACHINE & MODEL:	Colmar T10000FS	REFERENCE:	Dipper Extends by 1000mm
SERIAL No:	8443	DATE OF CHART:	29-May-2019
EQUIPMENT:	4.08m + 2.10m	SAFETY FACTOR:	67.0%
COMMENT:			

Colmar T10000FS
Max Capacity Contours of Radius(m) Plots 2.1m Dipper Cwt Out
Gradient 1 in -25 Height 2m Lift BP
Unlocked Rail Cant 50mm

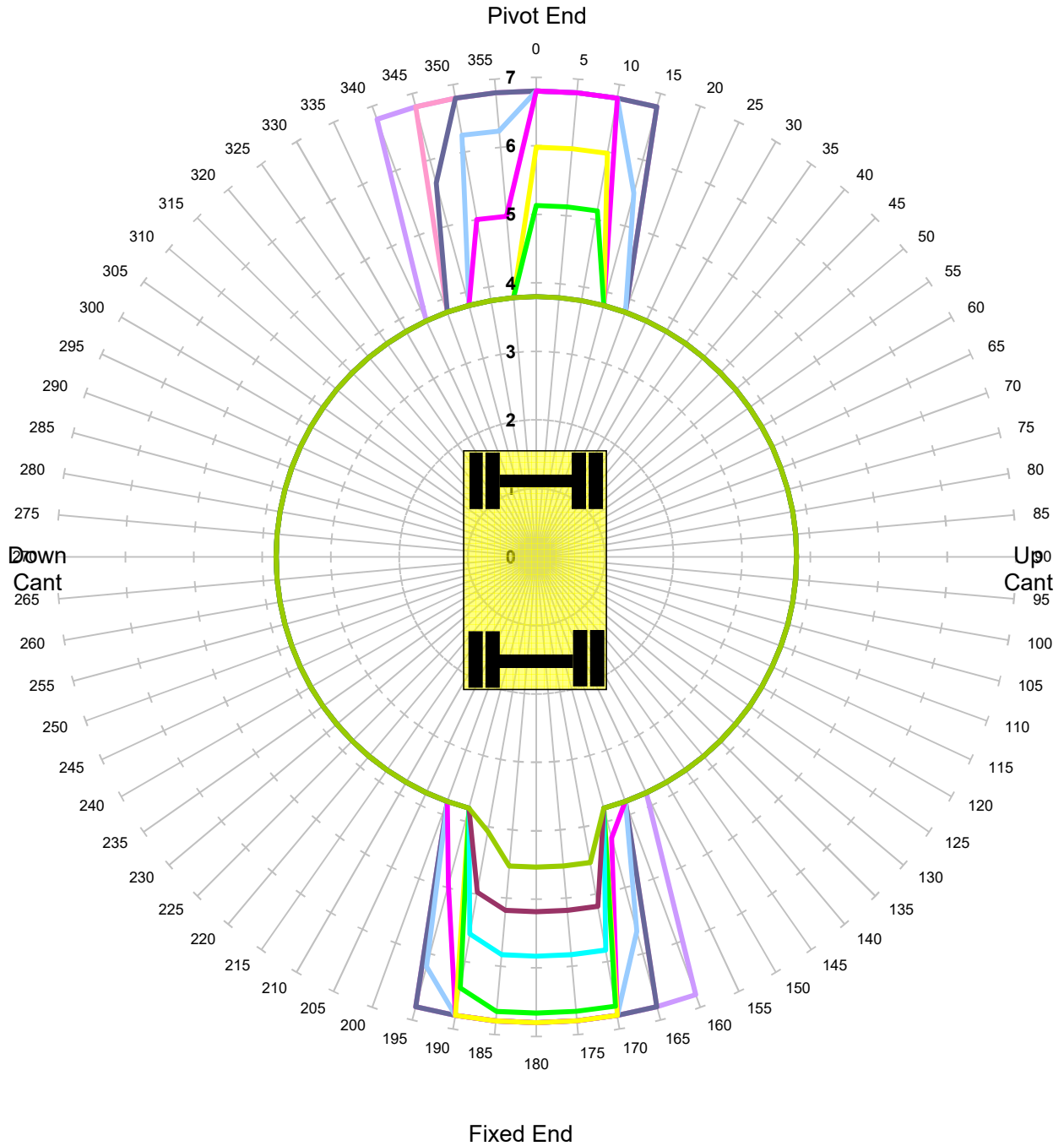

Units in Tonnes

- 1
- 2
- 3
- 4
- 5
- 6
- 7
- 8
- 9
- 10

MACHINE & MODEL:	Colmar T10000FS	REFERENCE:	Dipper Extends by 1000mm
SERIAL No:	8443	DATE OF CHART:	29-May-2019
EQUIPMENT:	4.08m + 2.10m	SAFETY FACTOR:	67.0%
COMMENT:			

Colmar T10000FS
Max Capacity Contours of Radius(m) Plots 2.1m Dipper Cwt Out
Gradient 1 in -25 Height 2m Lift BP
Unlocked Rail Cant 150mm

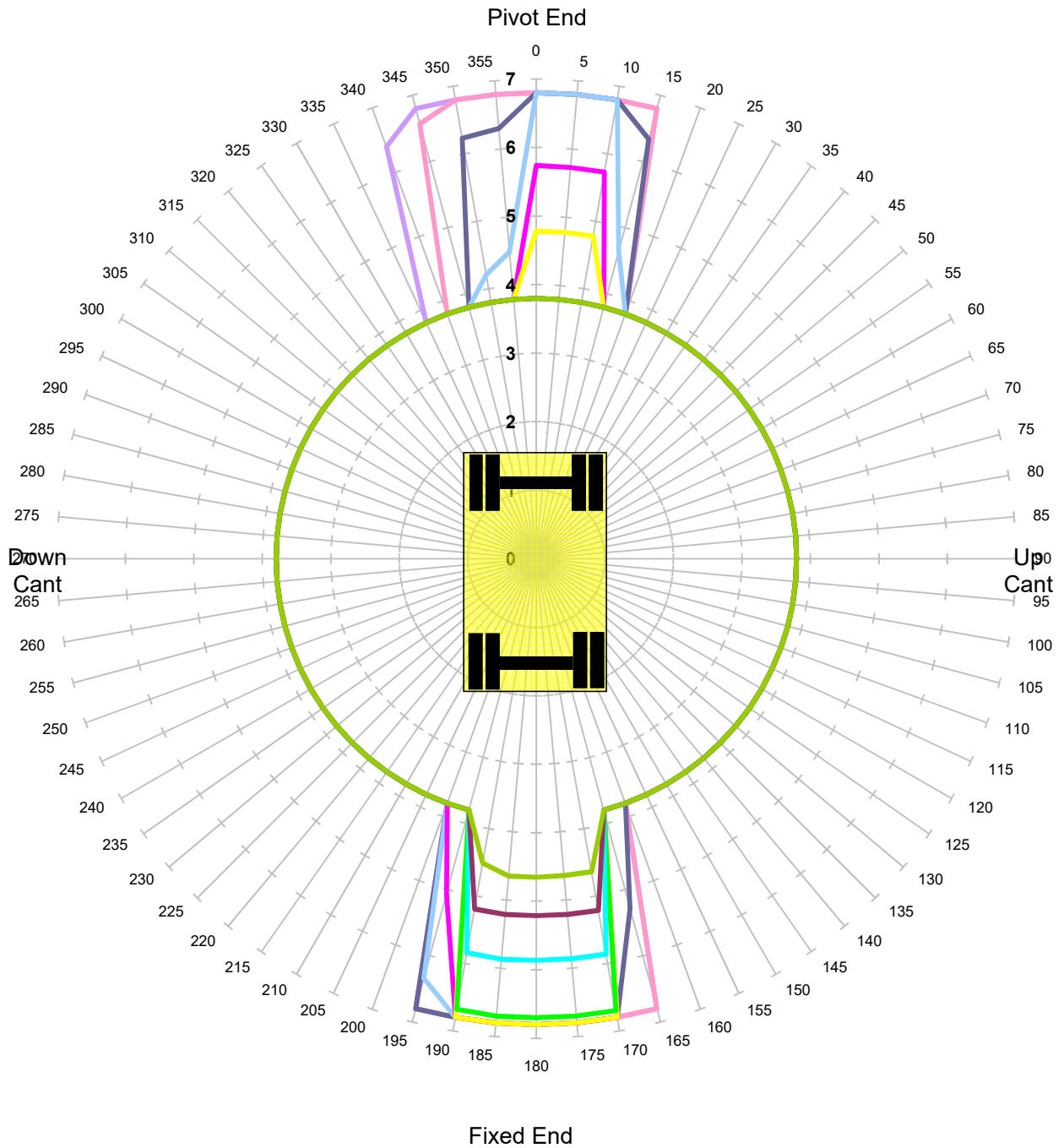

Units in Tonnes

- 1
- 2
- 3
- 4
- 5
- 6
- 7
- 8
- 9
- 10

MACHINE & MODEL:	Colmar T10000FS	REFERENCE:	Dipper Extends by 1000mm
SERIAL No:	8443	DATE OF CHART:	29-May-2019
EQUIPMENT:	4.08m + 2.10m	SAFETY FACTOR:	67.0%
COMMENT:			

Colmar T10000FS
Max Capacity Contours of Radius(m) Plots 2.1m Dipper Cwt Out
Gradient 1 in -25 Height 2m Lift BP
Locked Rail Cant -150mm

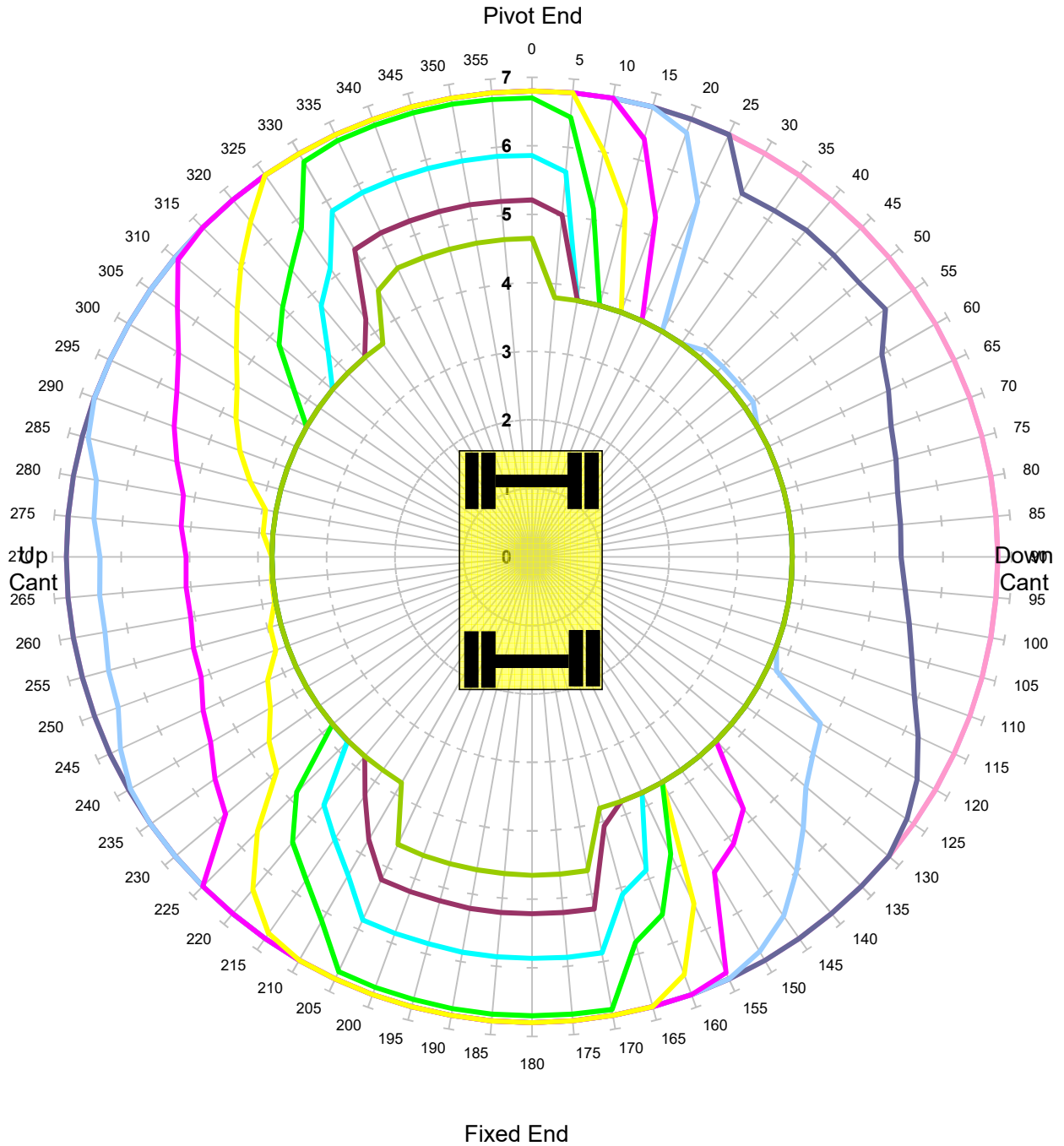

Units in Tonnes

- 1
 — 2
 — 3
 — 4
 — 5
 — 6
 — 7
 — 8
 — 9
 — 10

MACHINE & MODEL:	Colmar T10000FS	REFERENCE:	Dipper Extends by 1000mm
SERIAL No:	8443	DATE OF CHART:	29-May-2019
EQUIPMENT:	4.08m + 2.10m	SAFETY FACTOR:	90.0%
COMMENT:			

Colmar T10000FS

**Max Capacity Contours of Radius(m) Plots 2.1m Dipper Cwt Out
Gradient 1 in -25 Height 2m Lift BP
Locked Rail Cant -50mm**

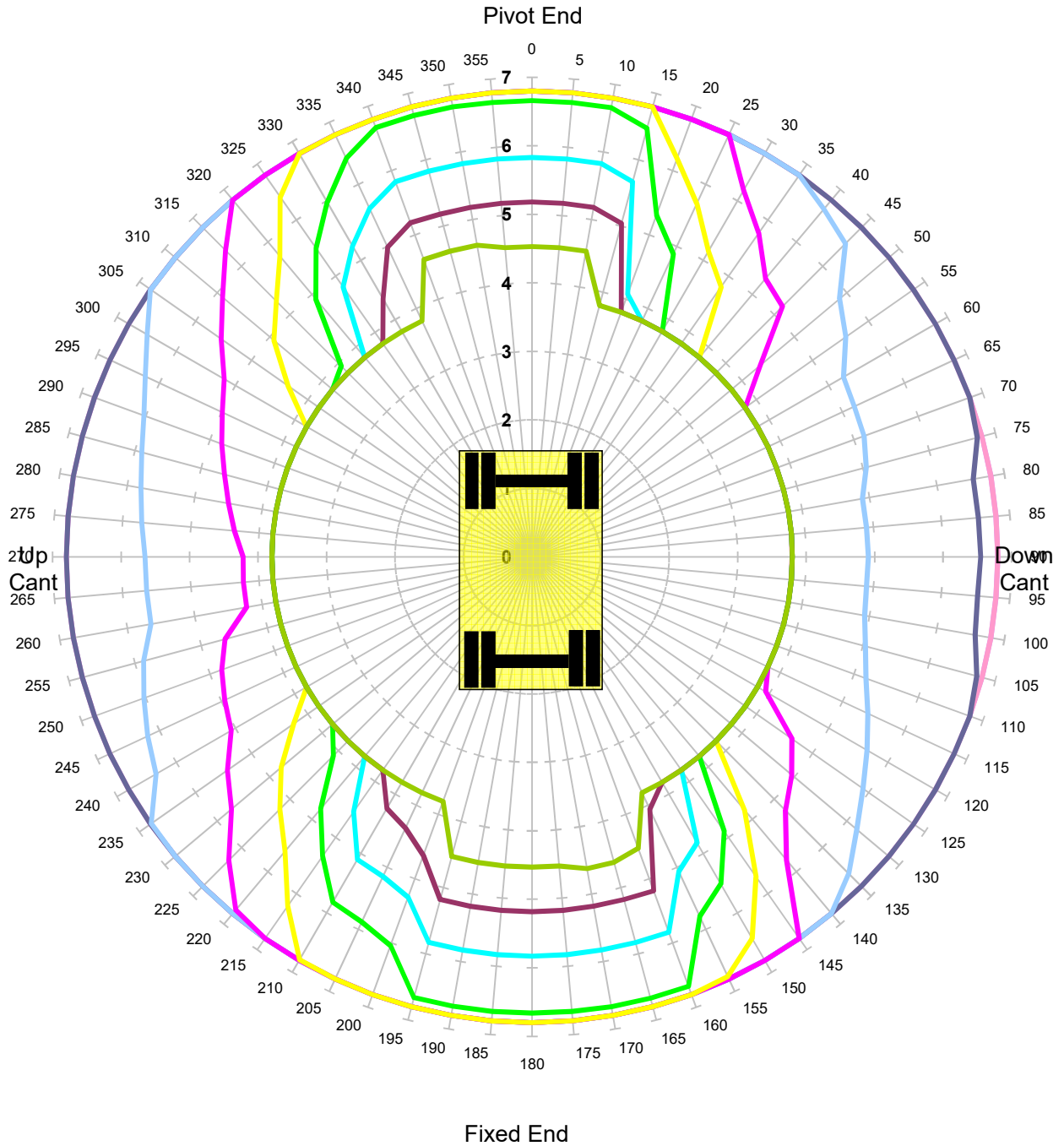

Units in Tonnes

- 1
- 2
- 3
- 4
- 5
- 6
- 7
- 8
- 9
- 10

MACHINE & MODEL:	Colmar T10000FS	REFERENCE:	Dipper Extends by 1000mm
SERIAL No:	8443	DATE OF CHART:	29-May-2019
EQUIPMENT:	4.08m + 2.10m	SAFETY FACTOR:	90.0%
COMMENT:			

Colmar T10000FS
Max Capacity Contours of Radius(m) Plots 2.1m Dipper Cwt Out
Gradient 1 in -25 Height 2m Lift BP
Locked Rail Cant 50mm

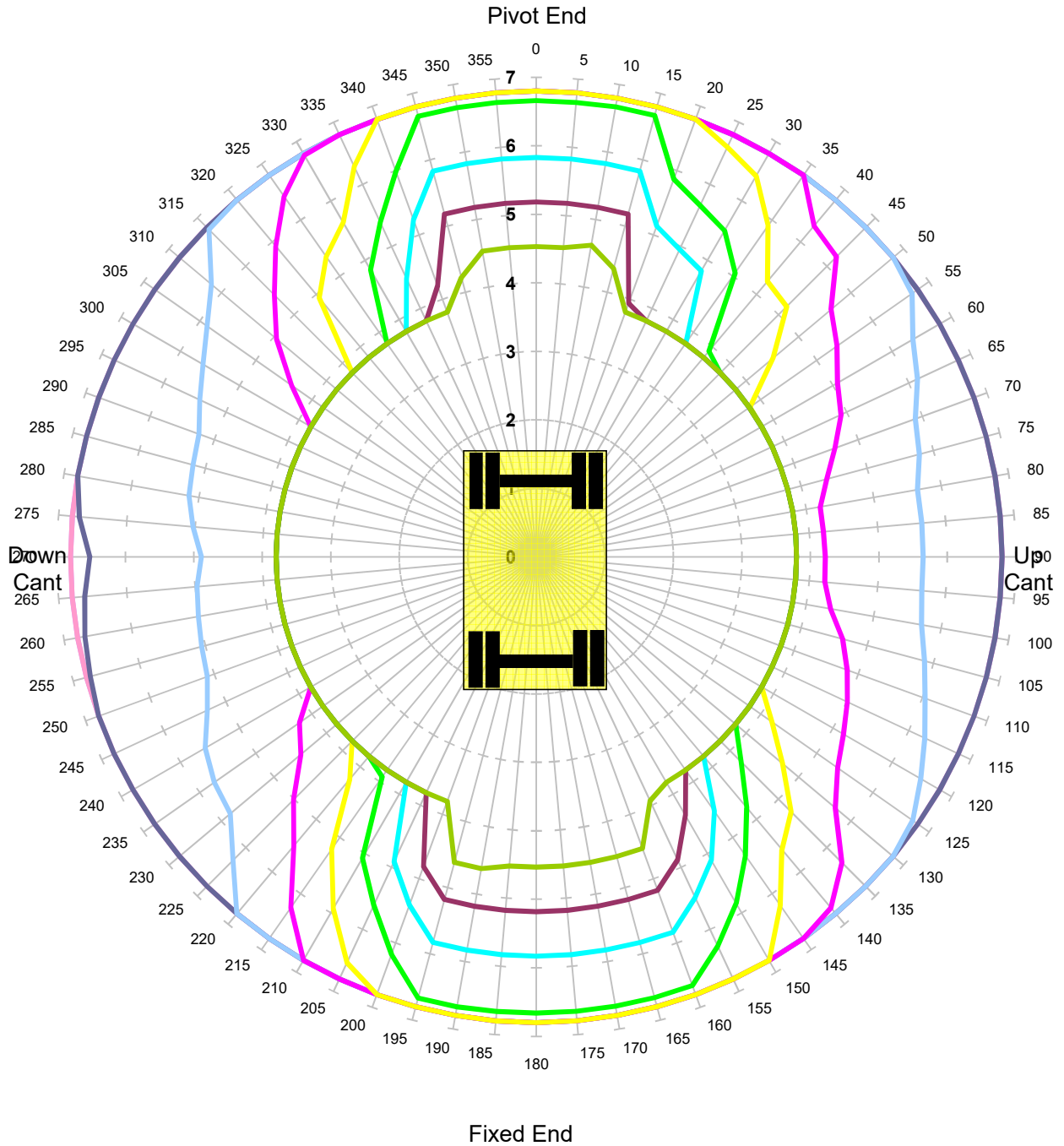

Units in Tonnes

- 1
- 2
- 3
- 4
- 5
- 6
- 7
- 8
- 9
- 10

MACHINE & MODEL:	Colmar T10000FS	REFERENCE:	Dipper Extends by 1000mm
SERIAL No:	8443	DATE OF CHART:	29-May-2019
EQUIPMENT:	4.08m + 2.10m	SAFETY FACTOR:	90.0%
COMMENT:			

Colmar T10000FS
Max Capacity Contours of Radius(m) Plots 2.1m Dipper Cwt Out
Gradient 1 in -25 Height 2m Lift BP
Locked Rail Cant 150mm

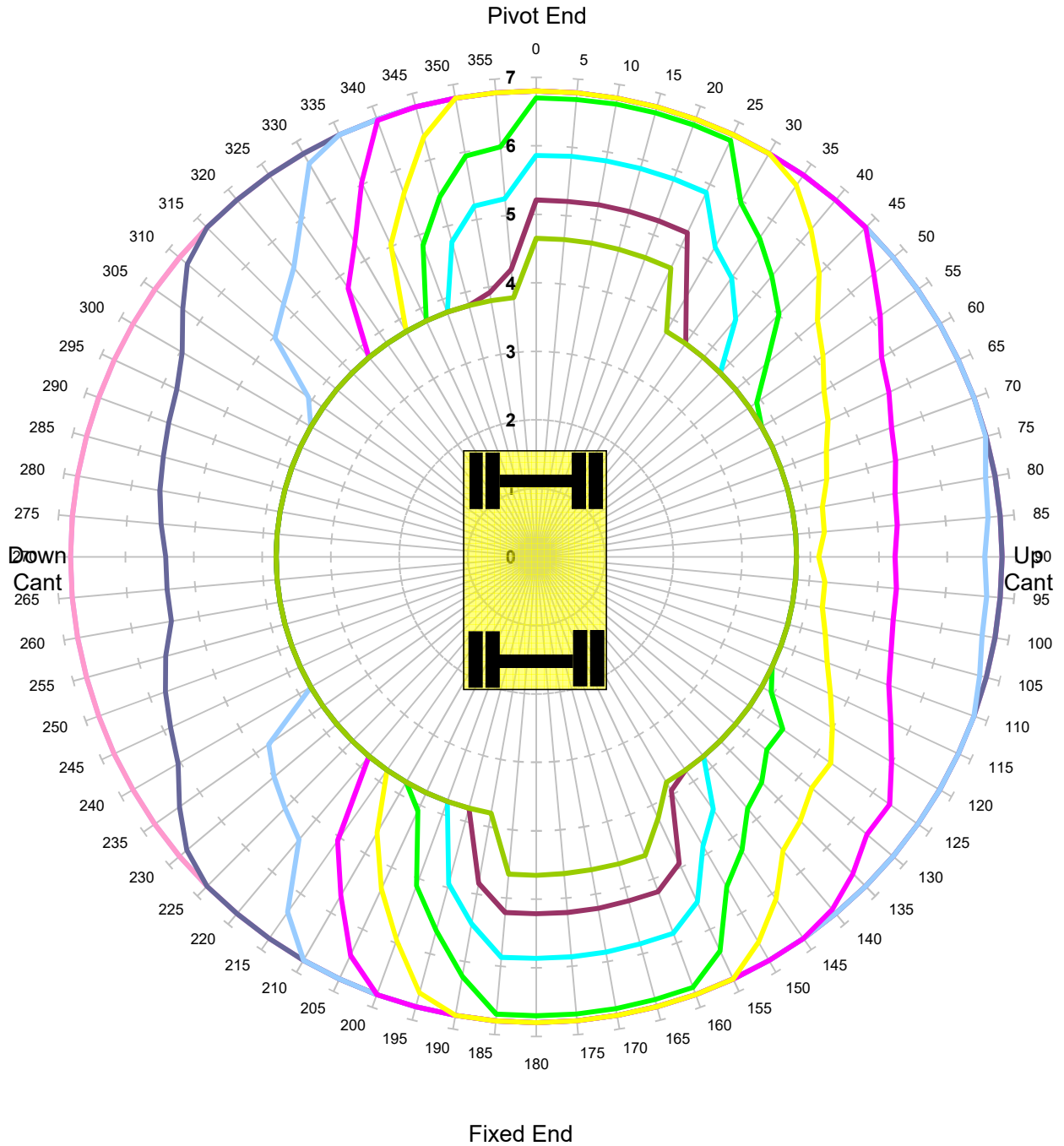

Units in Tonnes

- 1
- 2
- 3
- 4
- 5
- 6
- 7
- 8
- 9
- 10

MACHINE & MODEL:	Colmar T10000FS	REFERENCE:	Dipper Extends by 1000mm
SERIAL No:	8443	DATE OF CHART:	29-May-2019
EQUIPMENT:	4.08m + 2.10m	SAFETY FACTOR:	90.0%
COMMENT:			

Colmar T10000FS

**Max Capacity Contours of Radius(m) Plots 2.1m Dipper Cwt Out
Level Ground Height 2m Lift BP
Unlocked Road**

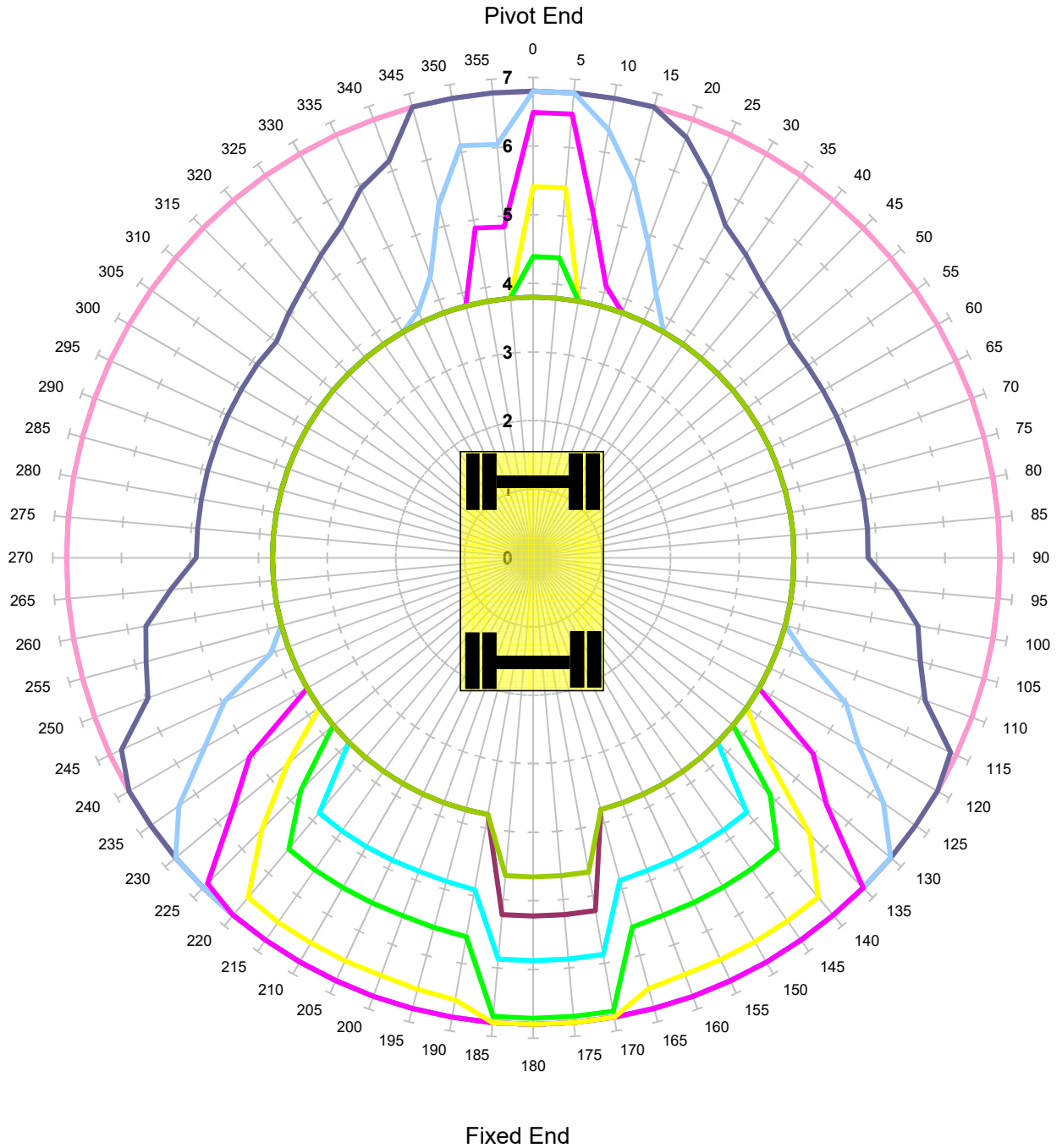

Units in Tonnes

- 1
- 2
- 3
- 4
- 5
- 6
- 7
- 8
- 9
- 10

MACHINE & MODEL:	Colmar T10000FS	REFERENCE:	Dipper Extends by 1000mm
SERIAL No:	8443	DATE OF CHART:	29-May-2019
EQUIPMENT:	4.08m + 2.10m	SAFETY FACTOR:	71.0%
COMMENT:			

Colmar T10000FS

**Max Capacity Contours of Radius(m) Plots 2.1m Dipper Cwt Out
Level Ground Height 2m Lift BP
Locked Road**

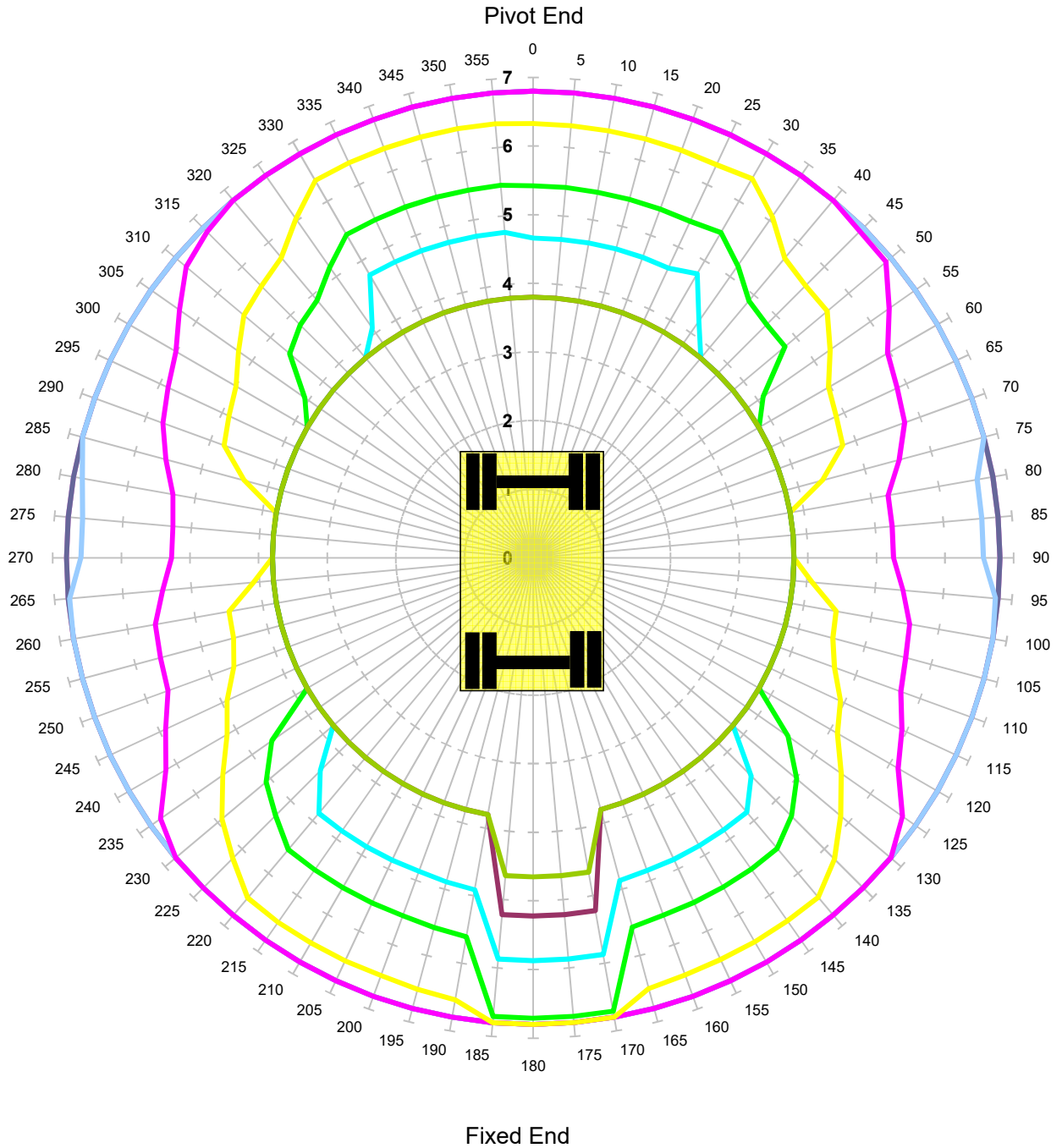

Units in Tonnes

- 1
 — 2
 — 3
 — 4
 — 5
 — 6
 — 7
 — 8
 — 9
 — 10

MACHINE & MODEL:	Colmar T10000FS	REFERENCE:	Dipper Extends by 1000mm
SERIAL No:	8443	DATE OF CHART:	29-May-2019
EQUIPMENT:	4.08m + 2.10m	SAFETY FACTOR:	71.0%
COMMENT:			

Colmar T10000FS

**Max Capacity Contours of Radius(m) Plots 2.1m Dipper Cwt Out
Gradient 1 in -25 Height 2m Lift BP**

Unlocked Rail Cant -150mm - Tandem Lift

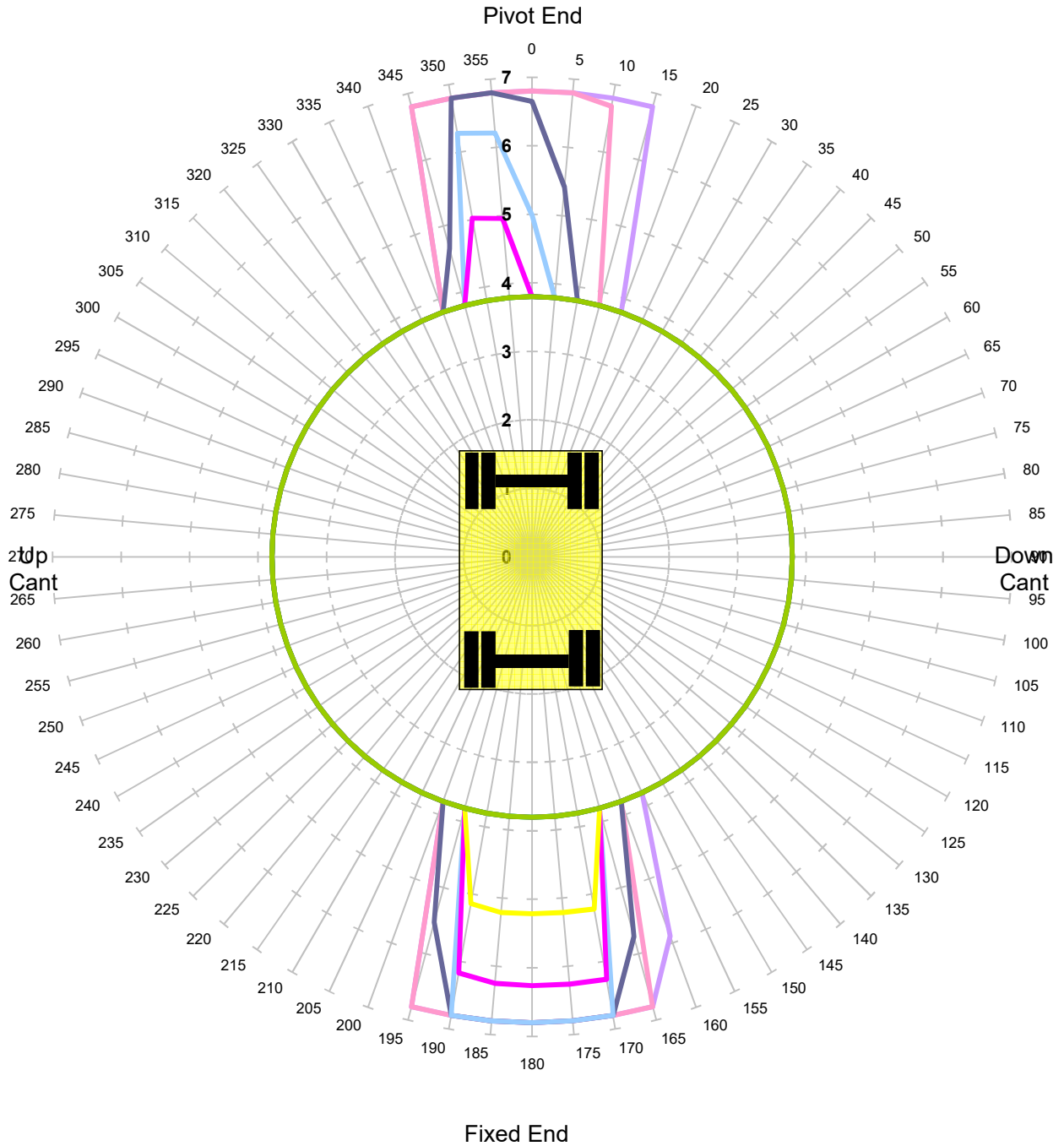

Units in Tonnes

- 1
- 2
- 3
- 4
- 5
- 6
- 7
- 8
- 9
- 10

MACHINE & MODEL:	Colmar T10000FS	REFERENCE:	Dipper Extends by 1000mm
SERIAL No:	8443	DATE OF CHART:	29-May-2019
EQUIPMENT:	4.08m + 2.10m	SAFETY FACTOR:	45.0%
COMMENT:			

Colmar T10000FS

**Max Capacity Contours of Radius(m) Plots 2.1m Dipper Cwt Out
Gradient 1 in -25 Height 2m Lift BP**

Unlocked Rail Cant -50mm - Tandem Lift

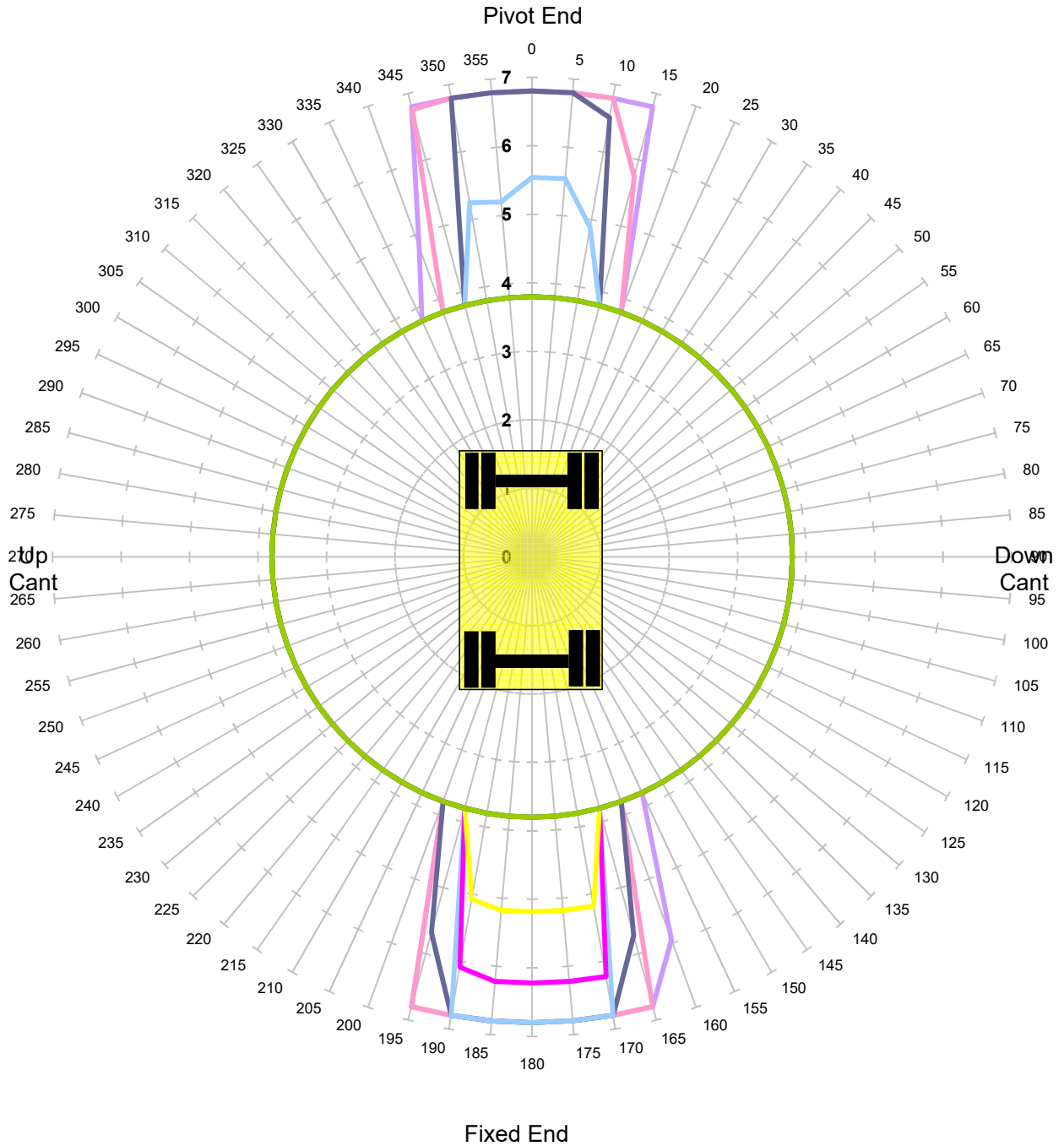

Units in Tonnes

- 1
 — 2
 — 3
 — 4
 — 5
 — 6
 — 7
 — 8
 — 9
 — 10

MACHINE & MODEL:	Colmar T10000FS	REFERENCE:	Dipper Extends by 1000mm
SERIAL No:	8443	DATE OF CHART:	29-May-2019
EQUIPMENT:	4.08m + 2.10m	SAFETY FACTOR:	45.0%
COMMENT:			

Colmar T10000FS

**Max Capacity Contours of Radius(m) Plots 2.1m Dipper Cwt Out
Gradient 1 in -25 Height 2m Lift BP**

Unlocked Rail Cant 50mm - Tandem Lift

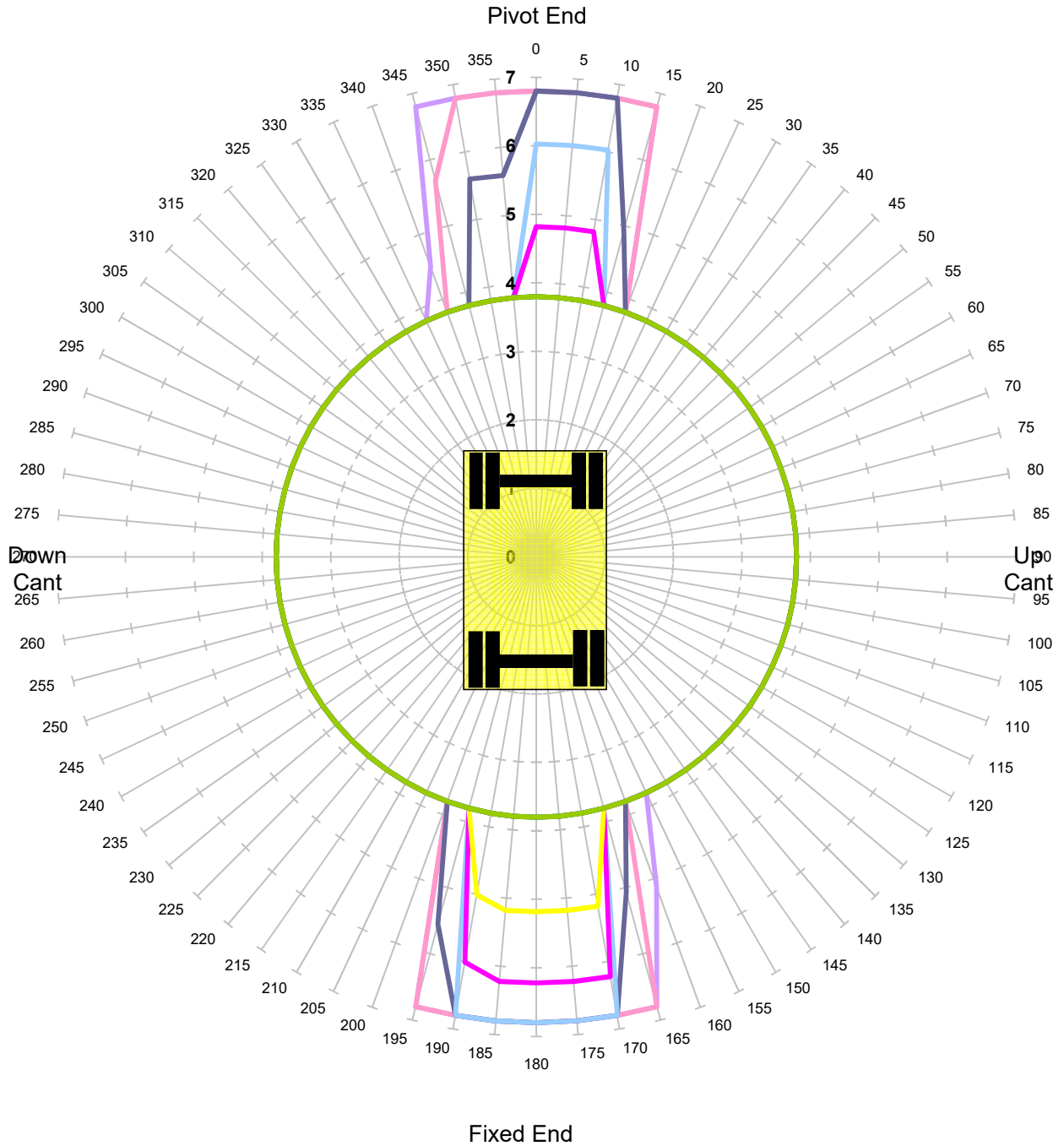

Units in Tonnes

- 1
 — 2
 — 3
 — 4
 — 5
 — 6
 — 7
 — 8
 — 9
 — 10

MACHINE & MODEL:	Colmar T10000FS	REFERENCE:	Dipper Extends by 1000mm
SERIAL No:	8443	DATE OF CHART:	29-May-2019
EQUIPMENT:	4.08m + 2.10m	SAFETY FACTOR:	45.0%
COMMENT:			

Colmar T10000FS

**Max Capacity Contours of Radius(m) Plots 2.1m Dipper Cwt Out
Gradient 1 in -25 Height 2m Lift BP**

Unlocked Rail Cant 150mm - Tandem Lift

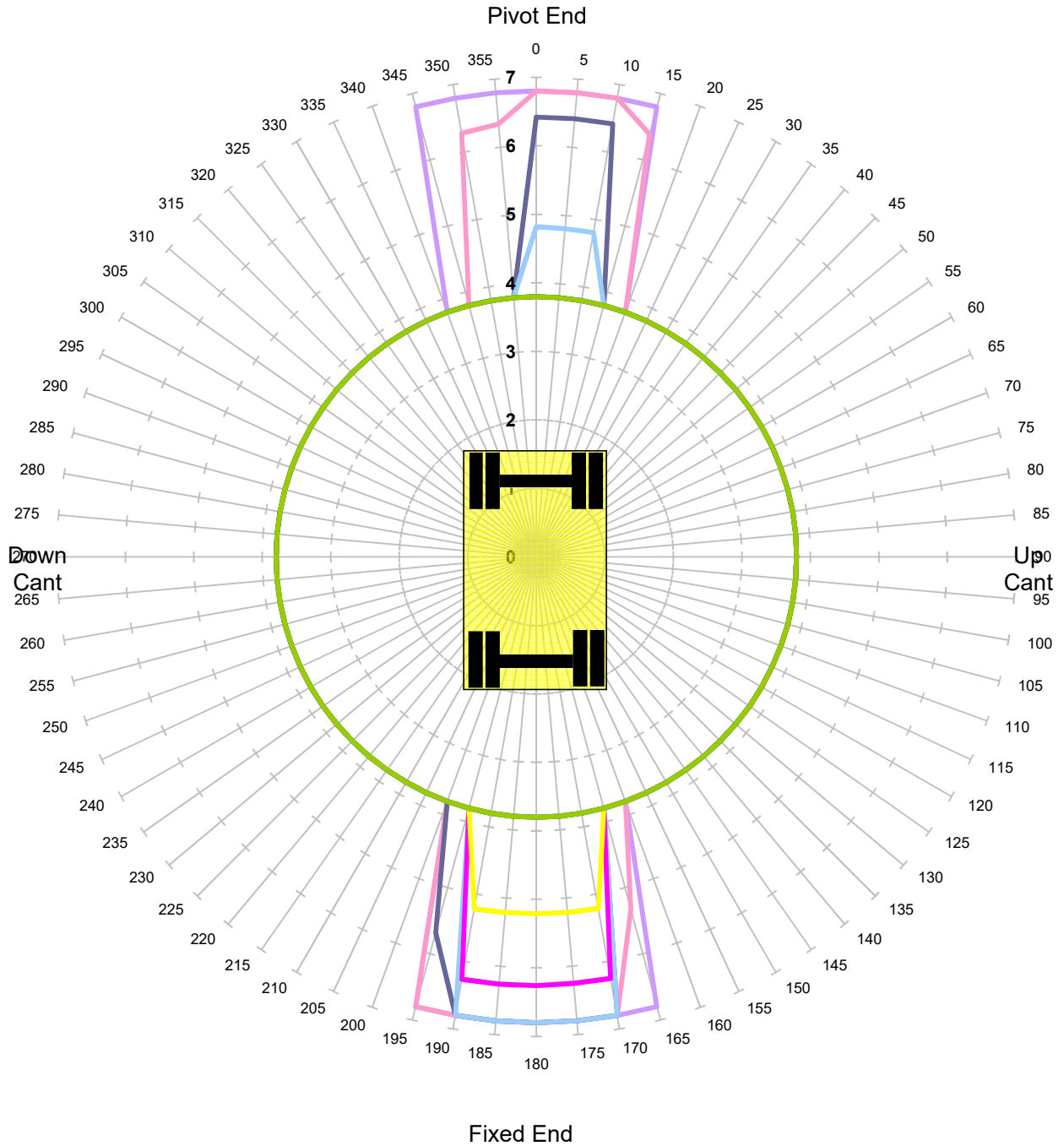

Units in Tonnes

- 1
 — 2
 — 3
 — 4
 — 5
 — 6
 — 7
 — 8
 — 9
 — 10

MACHINE & MODEL:	Colmar T10000FS	REFERENCE:	Dipper Extends by 1000mm
SERIAL No:	8443	DATE OF CHART:	29-May-2019
EQUIPMENT:	4.08m + 2.10m	SAFETY FACTOR:	45.0%
COMMENT:			

Colmar T1000FS

**Max Capacity Contours of Radius(m) Plots 2.1m Dipper Cwt Out
Gradient 1 in -25 Height 2m Lift BP**

Locked Rail Cant -150mm - Tandem Lift

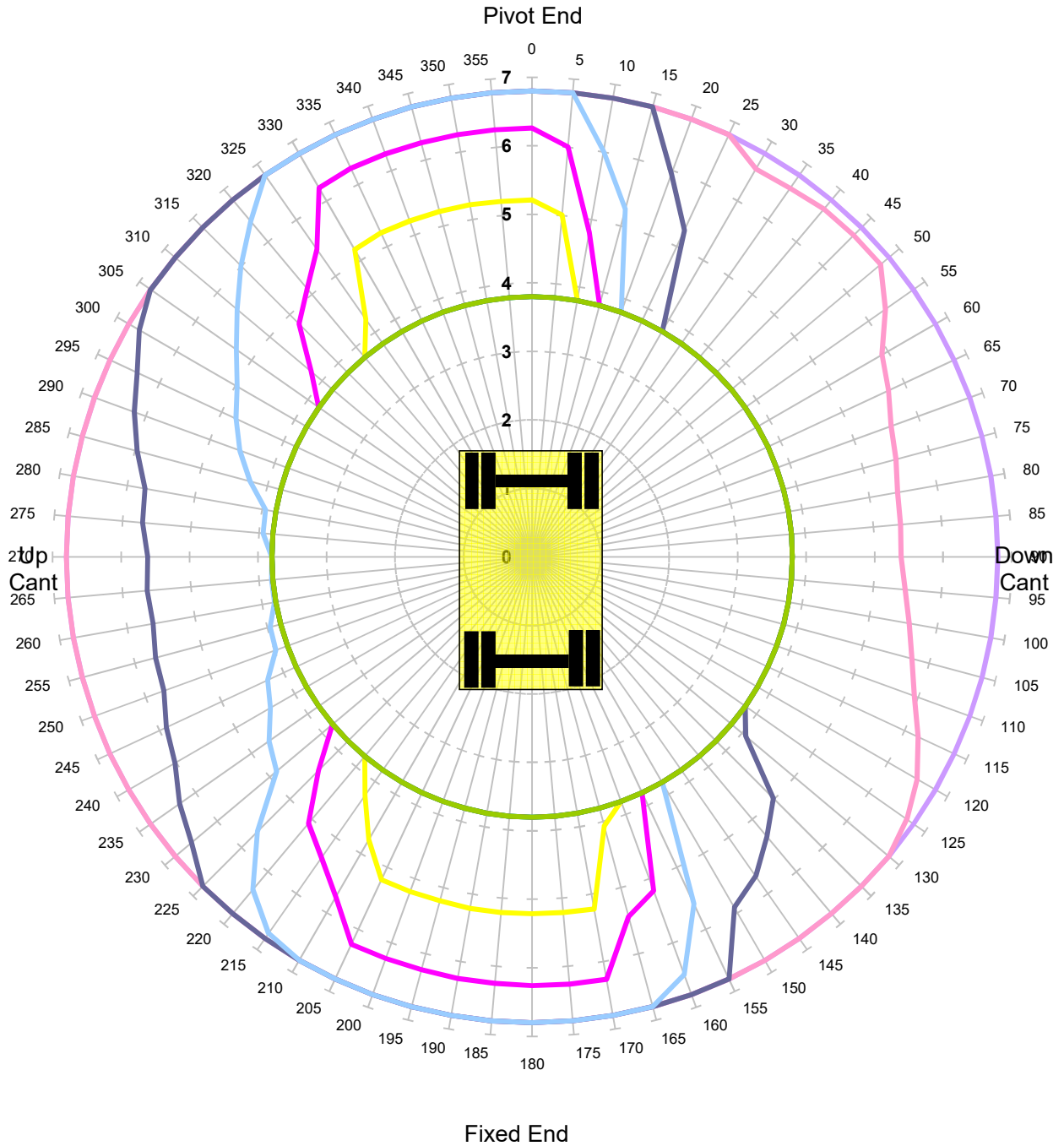

MACHINE & MODEL:	Colmar T1000FS	REFERENCE:	Dipper Extends by 1000mm
SERIAL No:	8443	DATE OF CHART:	29-May-2019
EQUIPMENT:	4.08m + 2.10m	SAFETY FACTOR:	60.0%
COMMENT:			

Colmar T10000FS

**Max Capacity Contours of Radius(m) Plots 2.1m Dipper Cwt Out
Gradient 1 in -25 Height 2m Lift BP**

Locked Rail Cant -50mm - Tandem Lift

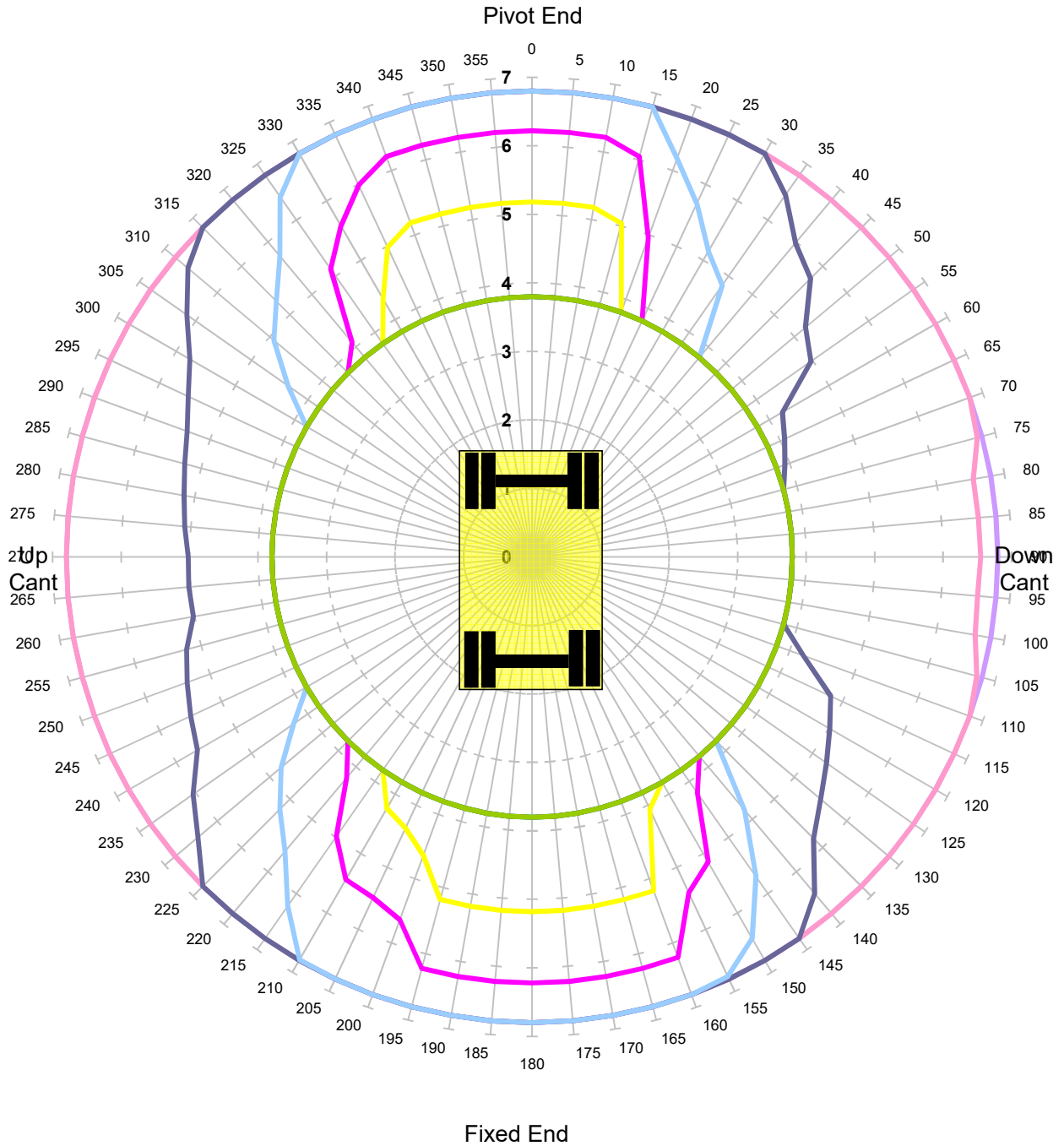

Units in Tonnes

- 1
 — 2
 — 3
 — 4
 — 5
 — 6
 — 7
 — 8
 — 9
 — 10

MACHINE & MODEL:	Colmar T10000FS	REFERENCE:	Dipper Extends by 1000mm
SERIAL No:	8443	DATE OF CHART:	29-May-2019
EQUIPMENT:	4.08m + 2.10m	SAFETY FACTOR:	60.0%
COMMENT:			

Colmar T10000FS

**Max Capacity Contours of Radius(m) Plots 2.1m Dipper Cwt Out
Gradient 1 in -25 Height 2m Lift BP
Locked Rail Cant 50mm - Tandem Lift**

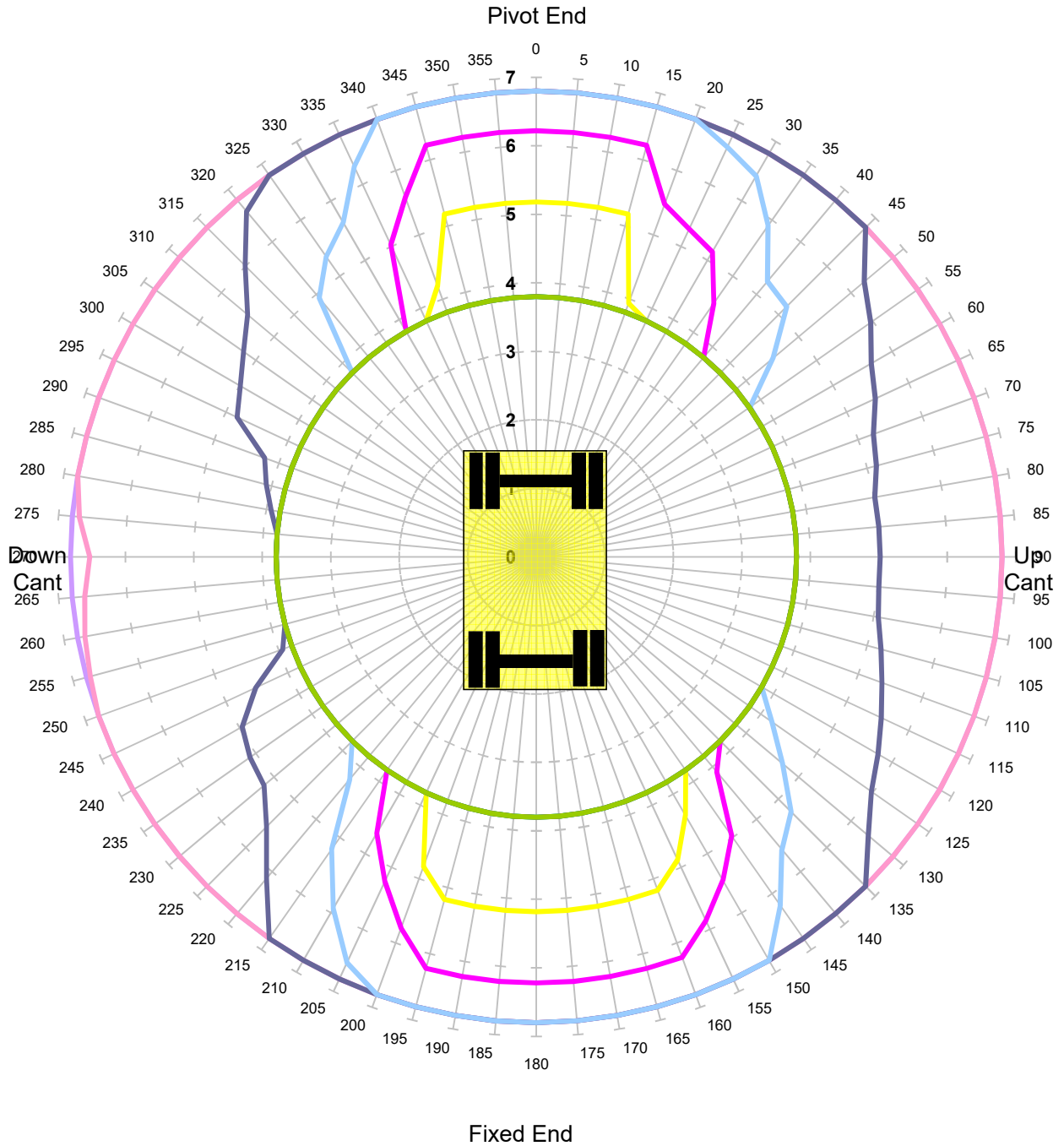

Units in Tonnes

- 1
- 2
- 3
- 4
- 5
- 6
- 7
- 8
- 9
- 10

MACHINE & MODEL:	Colmar T10000FS	REFERENCE:	Dipper Extends by 1000mm
SERIAL No:	8443	DATE OF CHART:	29-May-2019
EQUIPMENT:	4.08m + 2.10m	SAFETY FACTOR:	60.0%
COMMENT:			

Colmar T10000FS

**Max Capacity Contours of Radius(m) Plots 2.1m Dipper Cwt Out
Gradient 1 in -25 Height 2m Lift BP**

Locked Rail Cant 150mm - Tandem Lift

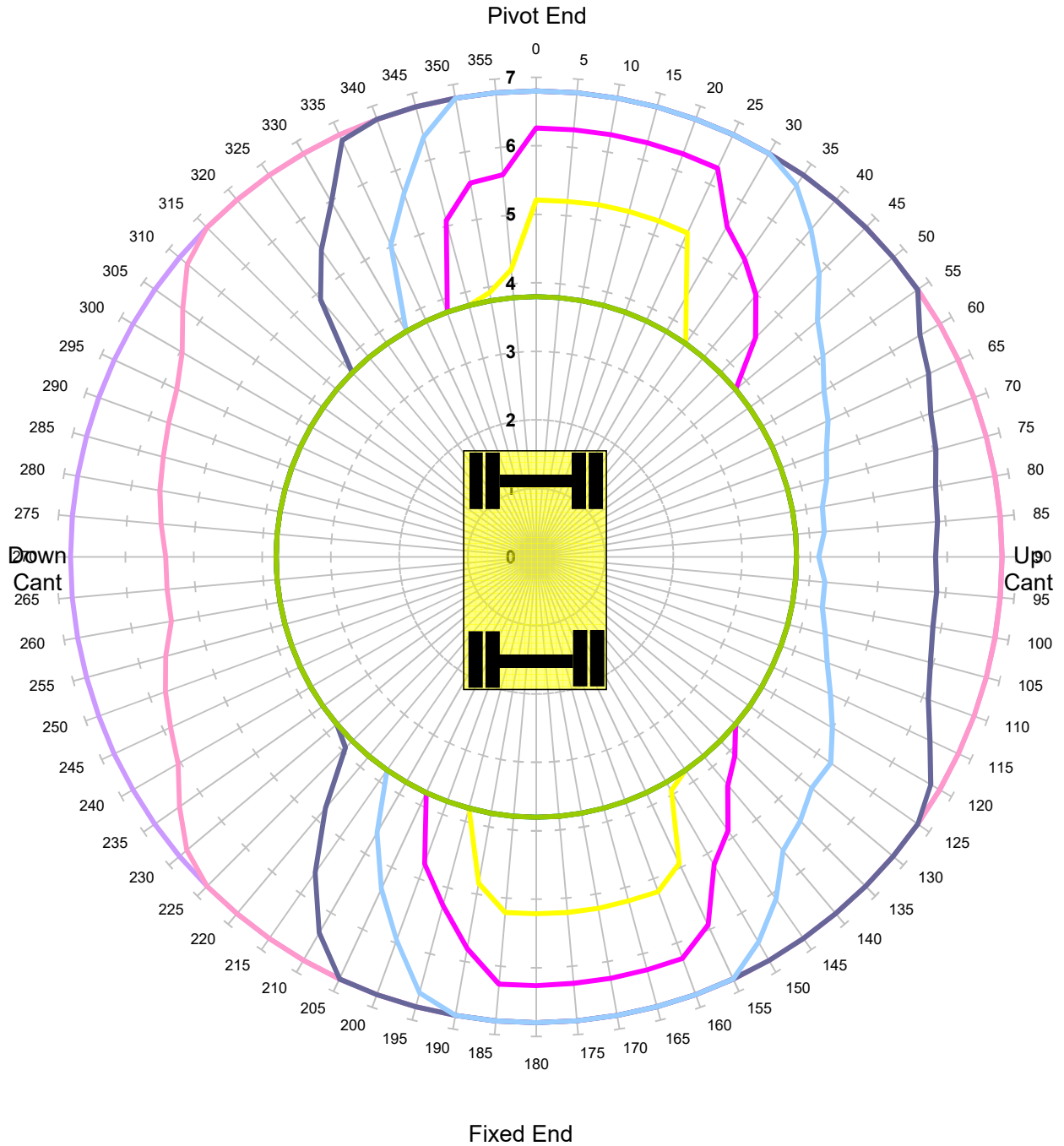

Units in Tonnes

- 1
 — 2
 — 3
 — 4
 — 5
 — 6
 — 7
 — 8
 — 9
 — 10

MACHINE & MODEL:	Colmar T10000FS	REFERENCE:	Dipper Extends by 1000mm
SERIAL No:	8443	DATE OF CHART:	29-May-2019
EQUIPMENT:	4.08m + 2.10m	SAFETY FACTOR:	60.0%
COMMENT:			

Colmar T1000FS

**Max Capacity Contours of Radius(m) Plots 2.1m Dipper Cwt Out
Level Ground Height 2m Lift BP
Unlocked Road - Tandem Lift**

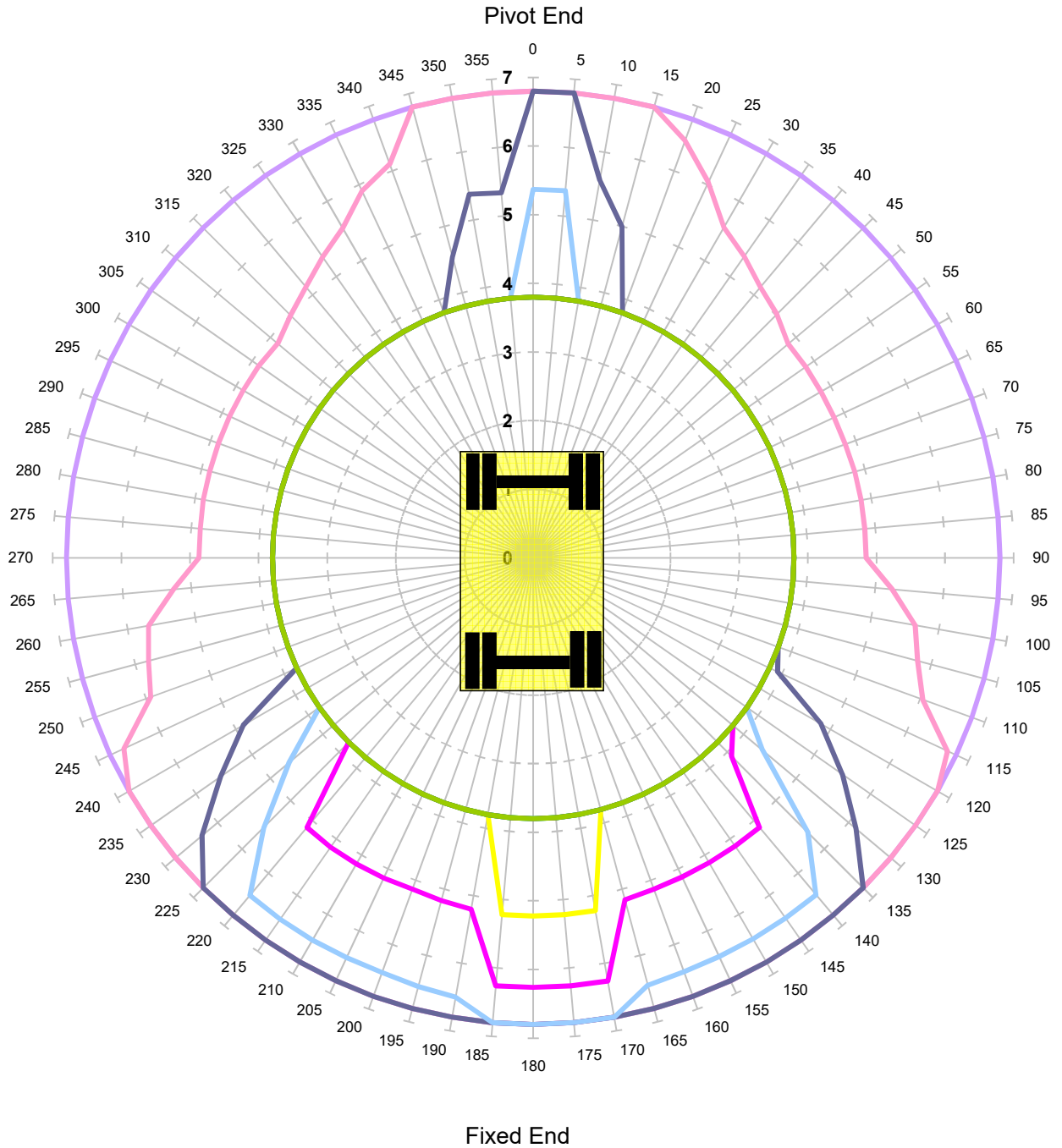

Units in Tonnes

- 1
 — 2
 — 3
 — 4
 — 5
 — 6
 — 7
 — 8
 — 9
 — 10

MACHINE & MODEL:	Colmar T1000FS	REFERENCE:	Dipper Extends by 1000mm
SERIAL No:	8443	DATE OF CHART:	29-May-2019
EQUIPMENT:	4.08m + 2.10m	SAFETY FACTOR:	47.0%
COMMENT:			

Colmar T1000FS
Max Capacity Contours of Radius(m) Plots 2.1m Dipper Cwt Out
Level Ground Height 2m Lift BP
Locked Road - Tandem Lift

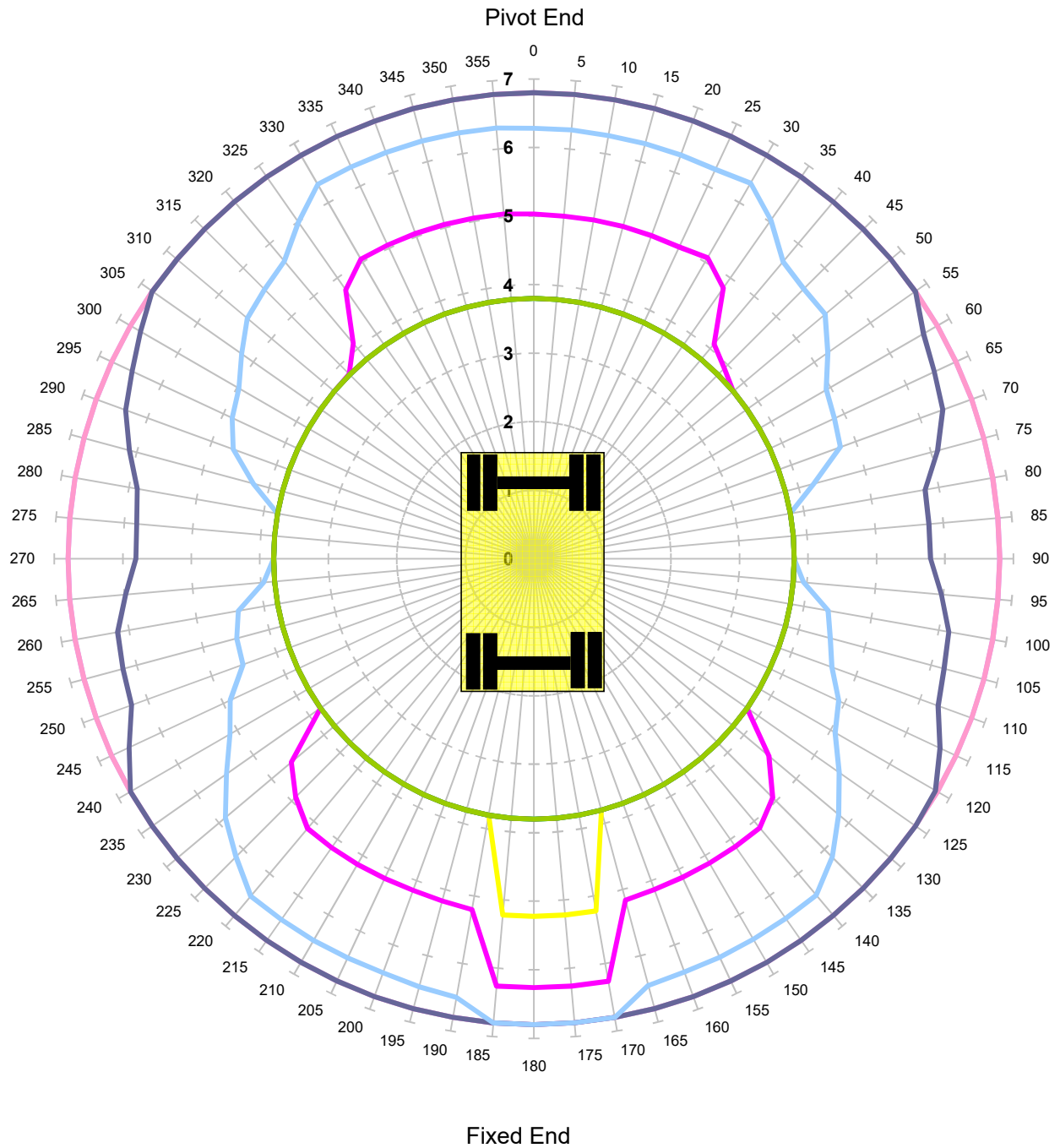

MACHINE & MODEL:	Colmar T1000FS	REFERENCE:	Dipper Extends by 1000mm
SERIAL No:	8443	DATE OF CHART:	29-May-2019
EQUIPMENT:	4.08m + 2.10m	SAFETY FACTOR:	47.0%
COMMENT:			

Colmar T10000FS

**Max Capacity Contours of Radius(m) Plots 3.1m Dipper Cwt Out
Gradient 1 in -25 Height 2m Lift BP
Unlocked Rail Cant -150mm**

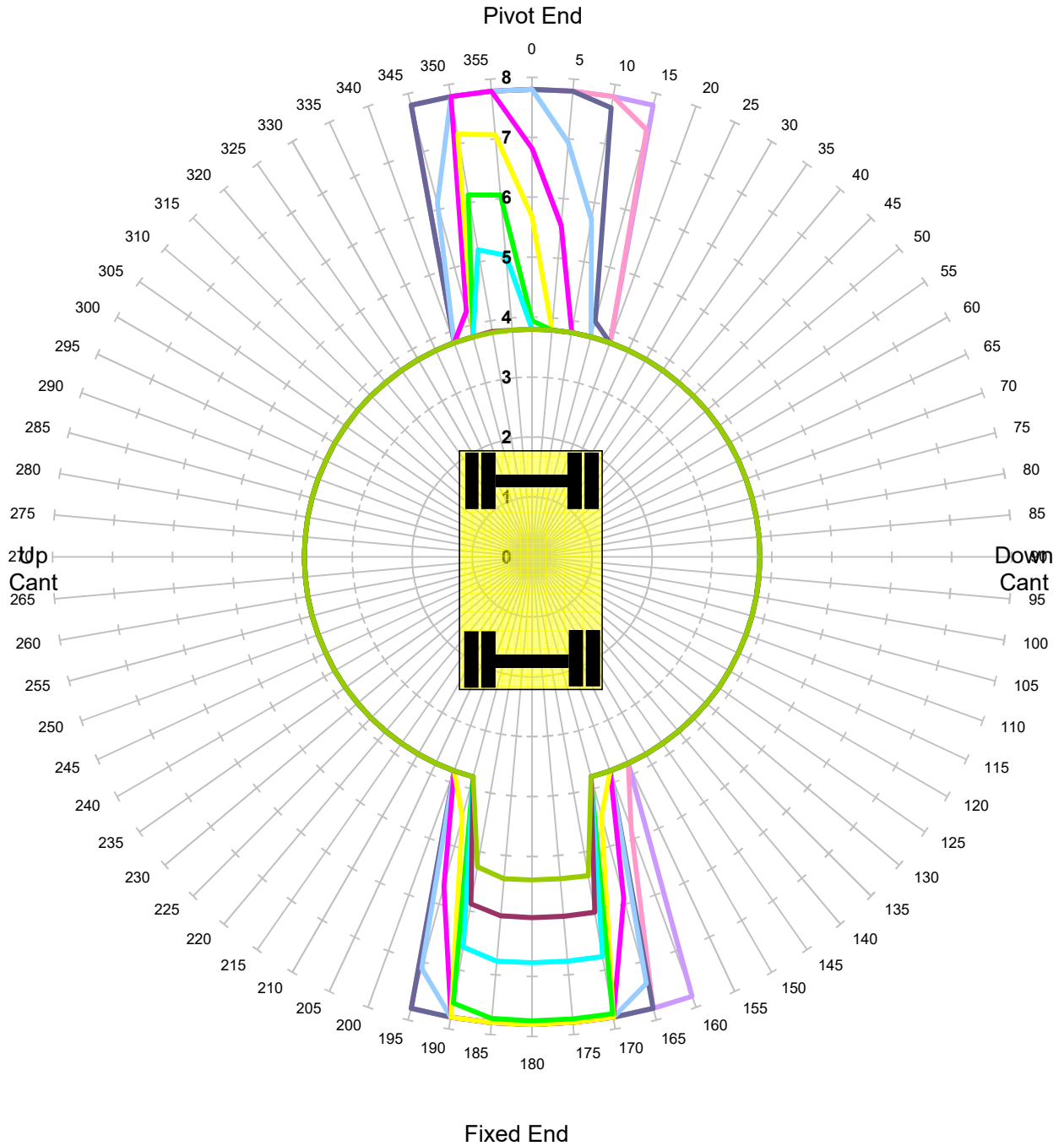

Units in Tonnes

- 1
- 2
- 3
- 4
- 5
- 6
- 7
- 8
- 9
- 10

MACHINE & MODEL:	Colmar T10000FS	REFERENCE:	Dipper Extends by 1000mm
SERIAL No:	8443	DATE OF CHART:	29-May-2019
EQUIPMENT:	4.08m + 2.10m	SAFETY FACTOR:	67.0%
COMMENT:			

Colmar T10000FS

**Max Capacity Contours of Radius(m) Plots 3.1m Dipper Cwt Out
Gradient 1 in -25 Height 2m Lift BP
Unlocked Rail Cant -50mm**

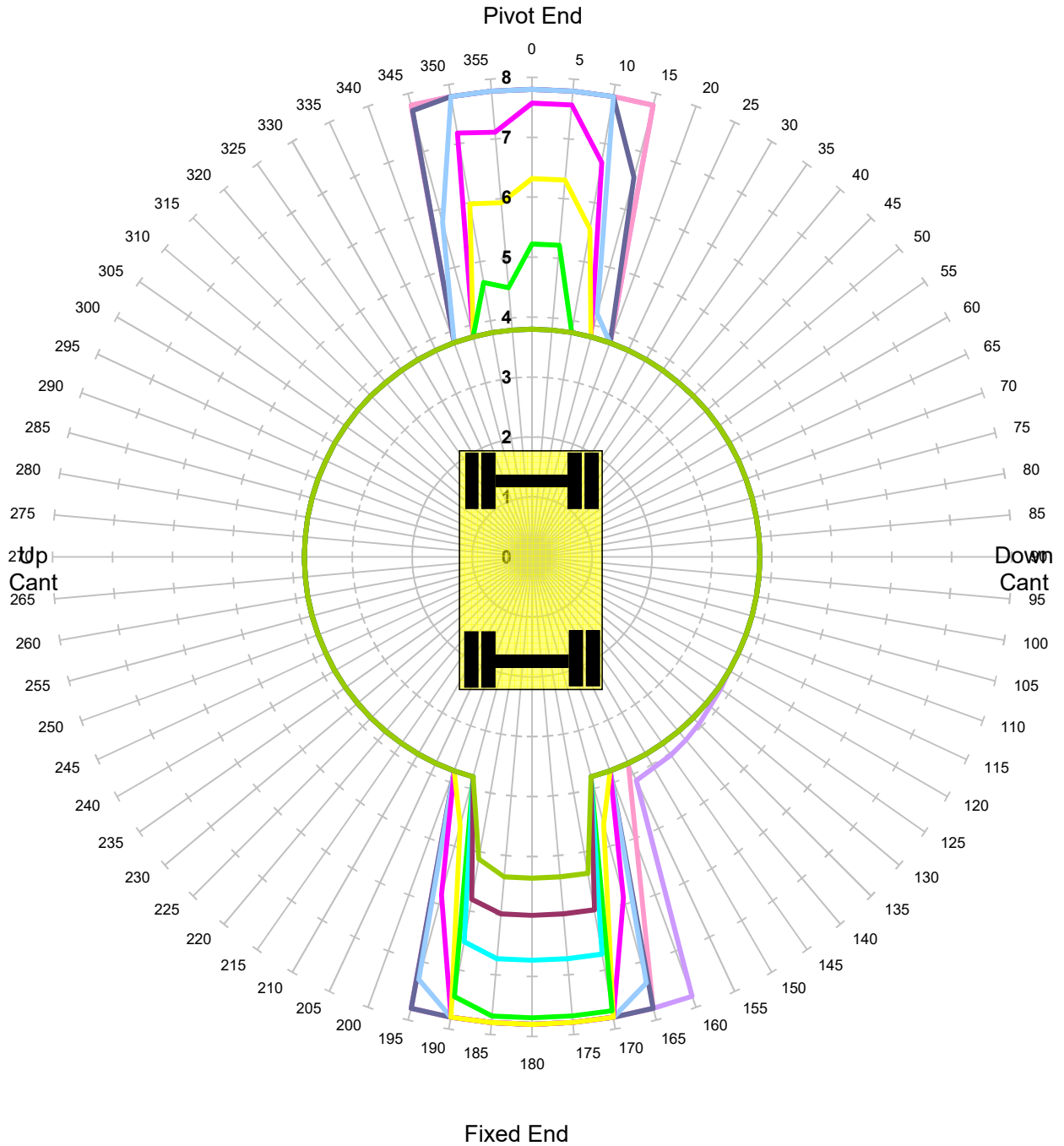

Units in Tonnes

- 1
 — 2
 — 3
 — 4
 — 5
 — 6
 — 7
 — 8
 — 9
 — 10

MACHINE & MODEL:	Colmar T10000FS	REFERENCE:	Dipper Extends by 1000mm
SERIAL No:	8443	DATE OF CHART:	29-May-2019
EQUIPMENT:	4.08m + 2.10m	SAFETY FACTOR:	67.0%
COMMENT:			

Colmar T10000FS
Max Capacity Contours of Radius(m) Plots 3.1m Dipper Cwt Out
Gradient 1 in -25 Height 2m Lift BP
Unlocked Rail Cant 50mm

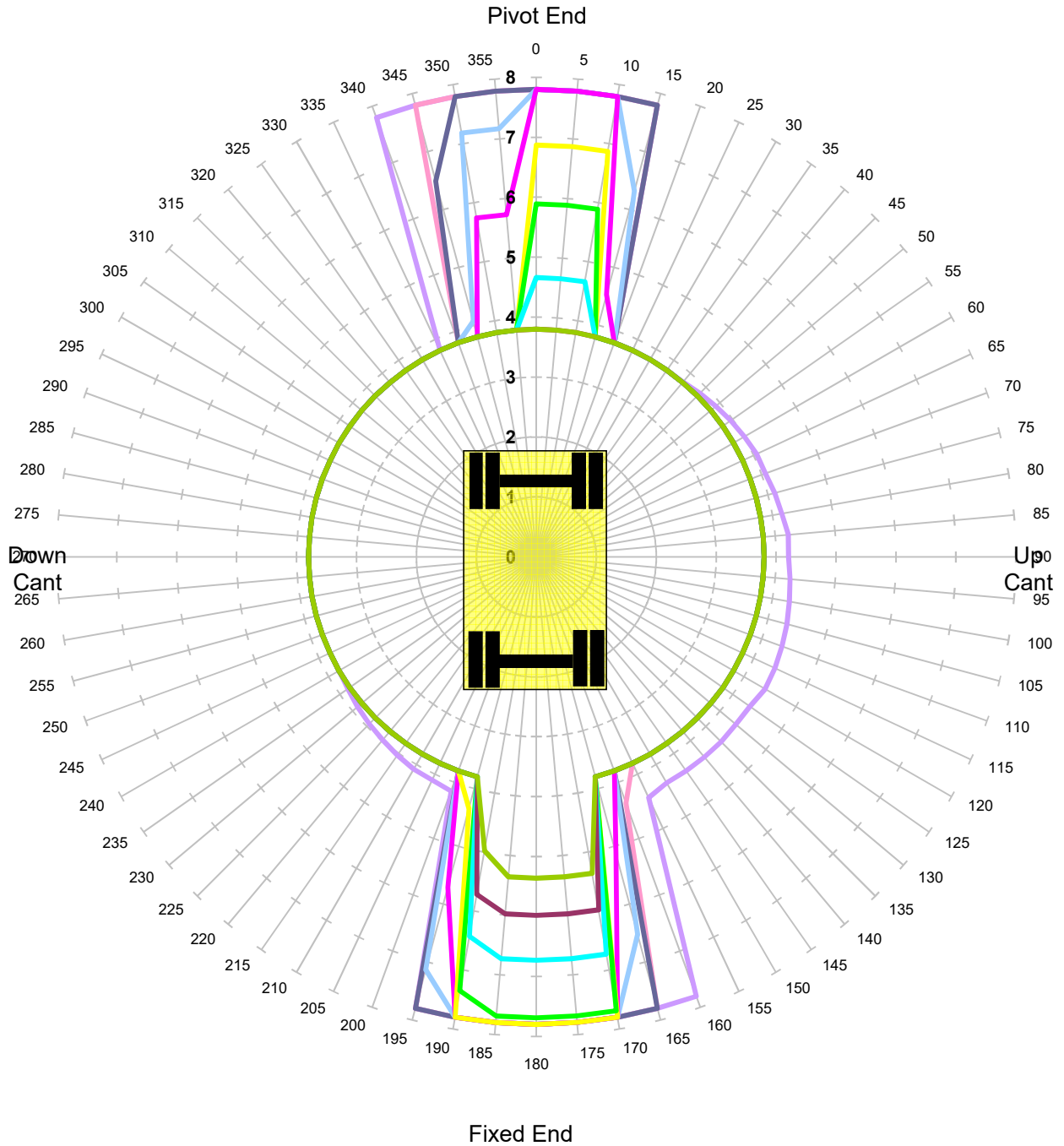

Units in Tonnes

- 1
- 2
- 3
- 4
- 5
- 6
- 7
- 8
- 9
- 10

MACHINE & MODEL:	Colmar T10000FS	REFERENCE:	Dipper Extends by 1000mm
SERIAL No:	8443	DATE OF CHART:	29-May-2019
EQUIPMENT:	4.08m + 2.10m	SAFETY FACTOR:	67.0%
COMMENT:			

Colmar T10000FS

**Max Capacity Contours of Radius(m) Plots 3.1m Dipper Cwt Out
Gradient 1 in -25 Height 2m Lift BP**

Unlocked Rail Cant 150mm

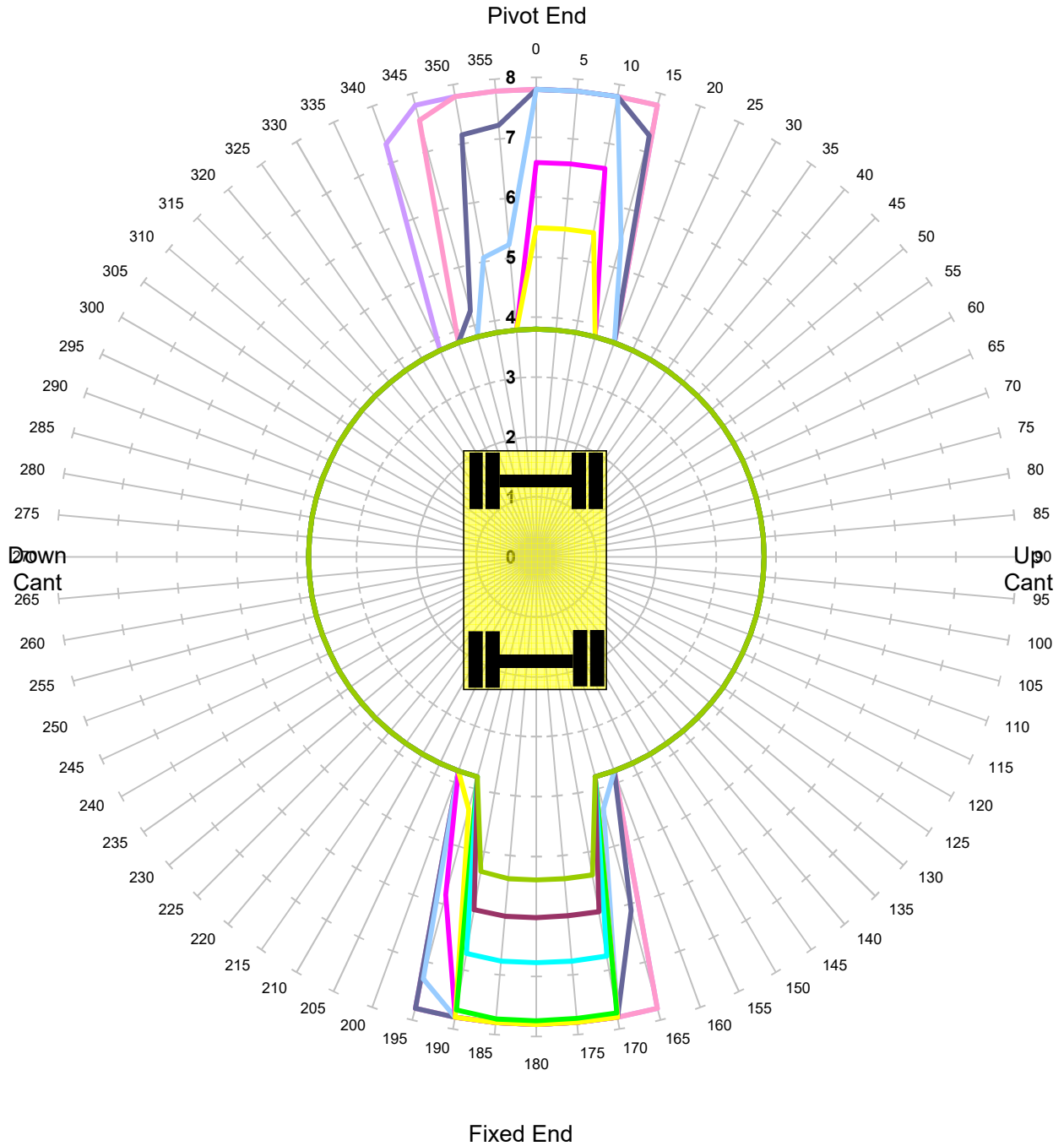

Units in Tonnes

- 1
 — 2
 — 3
 — 4
 — 5
 — 6
 — 7
 — 8
 — 9
 — 10

MACHINE & MODEL:	Colmar T10000FS	REFERENCE:	Dipper Extends by 1000mm
SERIAL No:	8443	DATE OF CHART:	29-May-2019
EQUIPMENT:	4.08m + 2.10m	SAFETY FACTOR:	67.0%
COMMENT:			

Colmar T1000FS
Max Capacity Contours of Radius(m) Plots 3.1m Dipper Cwt Out
Gradient 1 in -25 Height 2m Lift BP
Locked Rail Cant -150mm

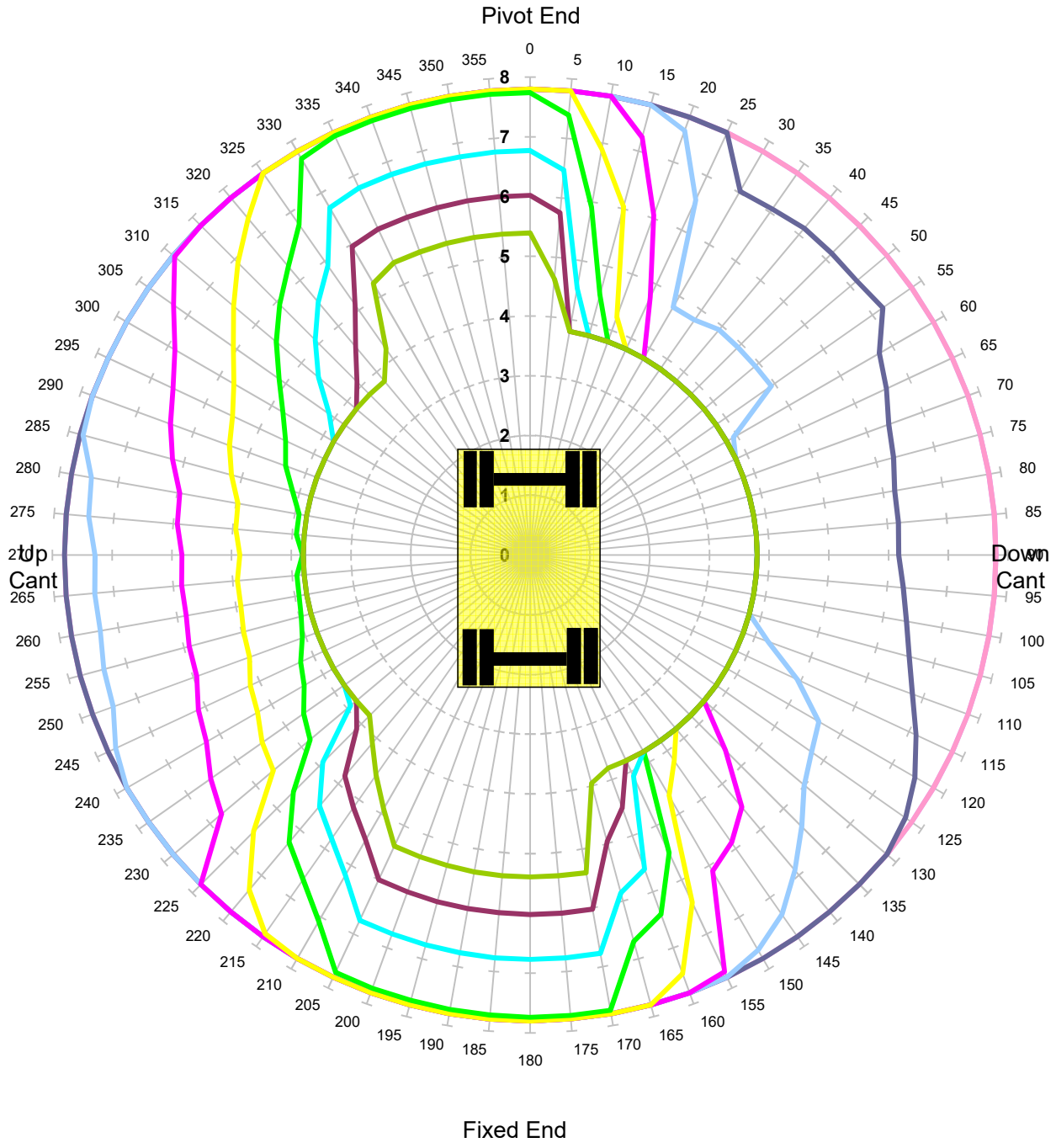

MACHINE & MODEL:	Colmar T1000FS	REFERENCE:	Dipper Extends by 1000mm
SERIAL No:	8443	DATE OF CHART:	29-May-2019
EQUIPMENT:	4.08m + 2.10m	SAFETY FACTOR:	90.0%
COMMENT:			

Colmar T10000FS
Max Capacity Contours of Radius(m) Plots 3.1m Dipper Cwt Out
Gradient 1 in -25 Height 2m Lift BP
Locked Rail Cant -50mm

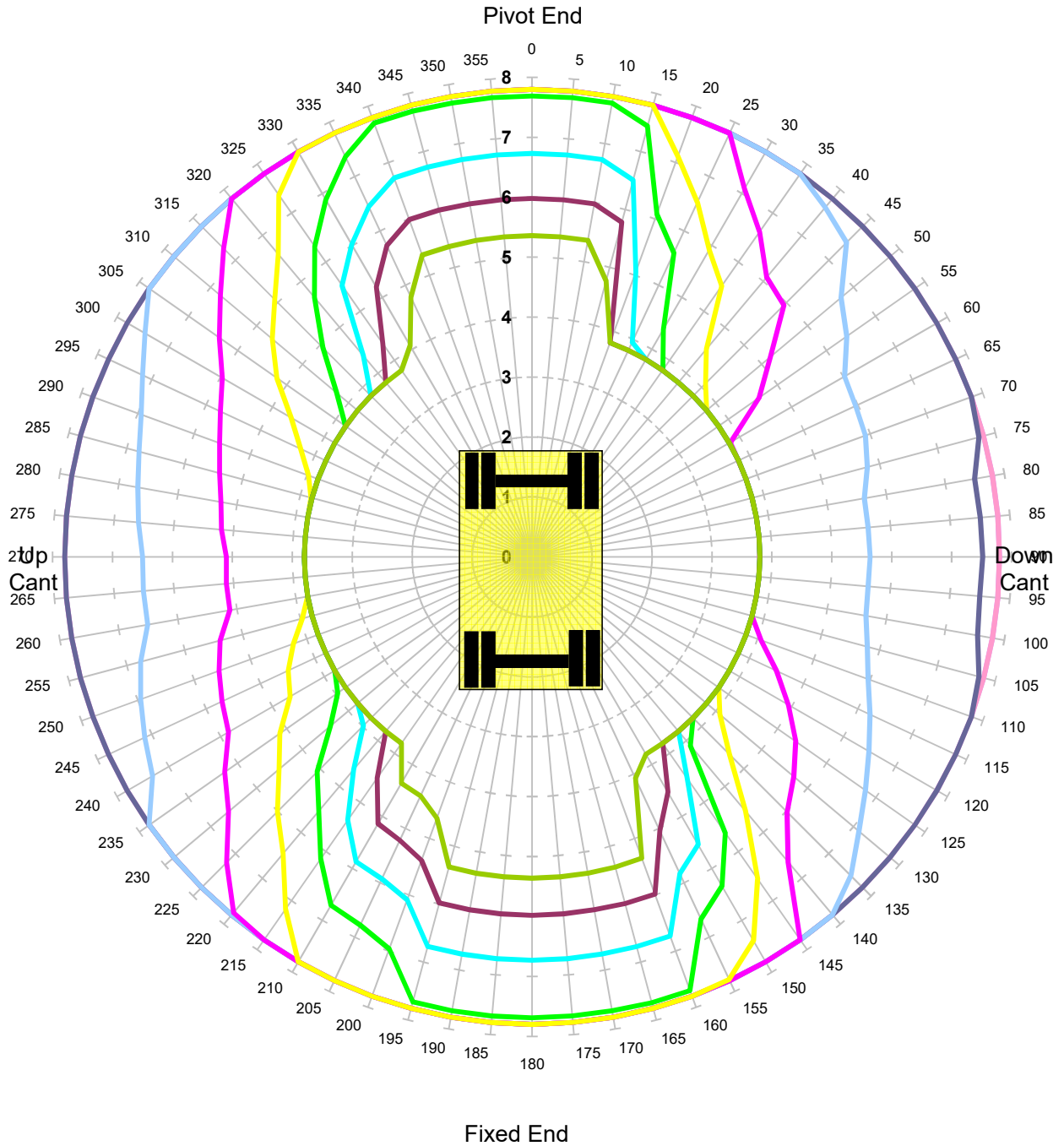

Units in Tonnes

- 1
- 2
- 3
- 4
- 5
- 6
- 7
- 8
- 9
- 10

MACHINE & MODEL:	Colmar T10000FS	REFERENCE:	Dipper Extends by 1000mm
SERIAL No:	8443	DATE OF CHART:	29-May-2019
EQUIPMENT:	4.08m + 2.10m	SAFETY FACTOR:	90.0%
COMMENT:			

Colmar T10000FS
Max Capacity Contours of Radius(m) Plots 3.1m Dipper Cwt Out
Gradient 1 in -25 Height 2m Lift BP
Locked Rail Cant 50mm

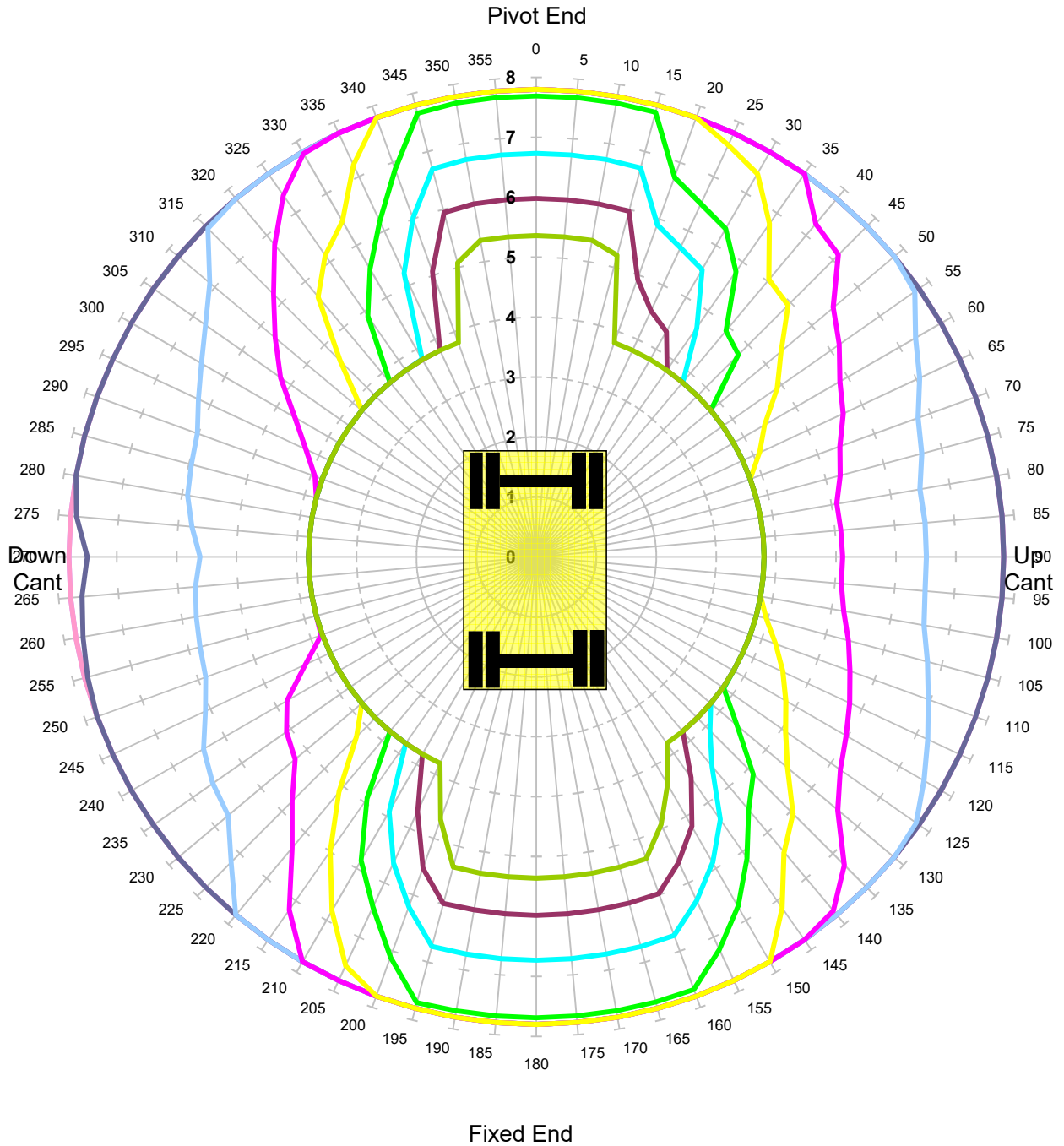

Units in Tonnes

- 1
- 2
- 3
- 4
- 5
- 6
- 7
- 8
- 9
- 10

MACHINE & MODEL:	Colmar T10000FS	REFERENCE:	Dipper Extends by 1000mm
SERIAL No:	8443	DATE OF CHART:	29-May-2019
EQUIPMENT:	4.08m + 2.10m	SAFETY FACTOR:	90.0%
COMMENT:			

Colmar T10000FS
Max Capacity Contours of Radius(m) Plots 3.1m Dipper Cwt Out
Gradient 1 in -25 Height 2m Lift BP
Locked Rail Cant 150mm

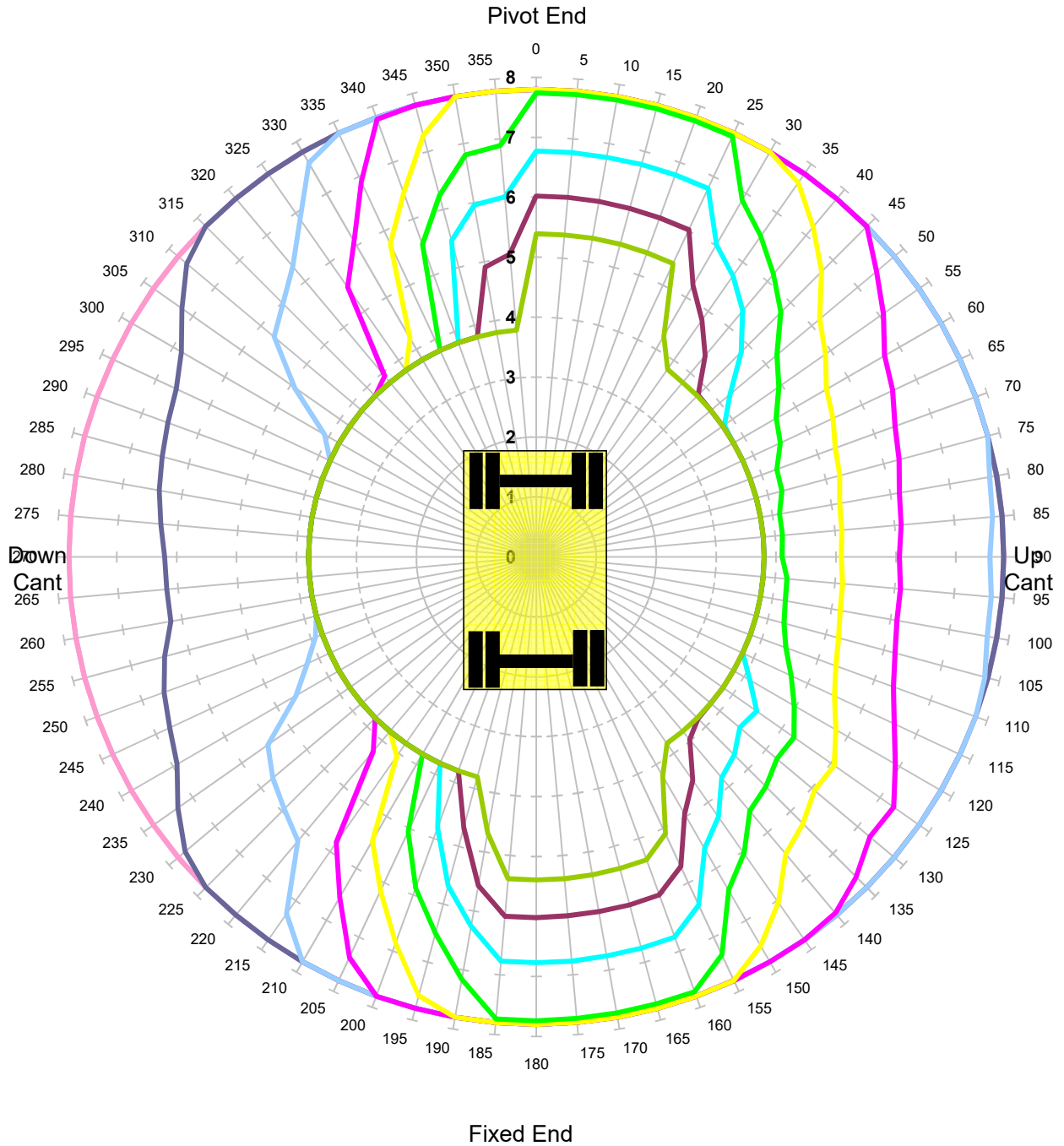

Units in Tonnes

- 1
- 2
- 3
- 4
- 5
- 6
- 7
- 8
- 9
- 10

MACHINE & MODEL:	Colmar T10000FS	REFERENCE:	Dipper Extends by 1000mm
SERIAL No:	8443	DATE OF CHART:	29-May-2019
EQUIPMENT:	4.08m + 2.10m	SAFETY FACTOR:	90.0%
COMMENT:			

Colmar T10000FS

**Max Capacity Contours of Radius(m) Plots 3.1m Dipper Cwt Out
Level Ground Height 2m Lift BP
Unlocked Road**

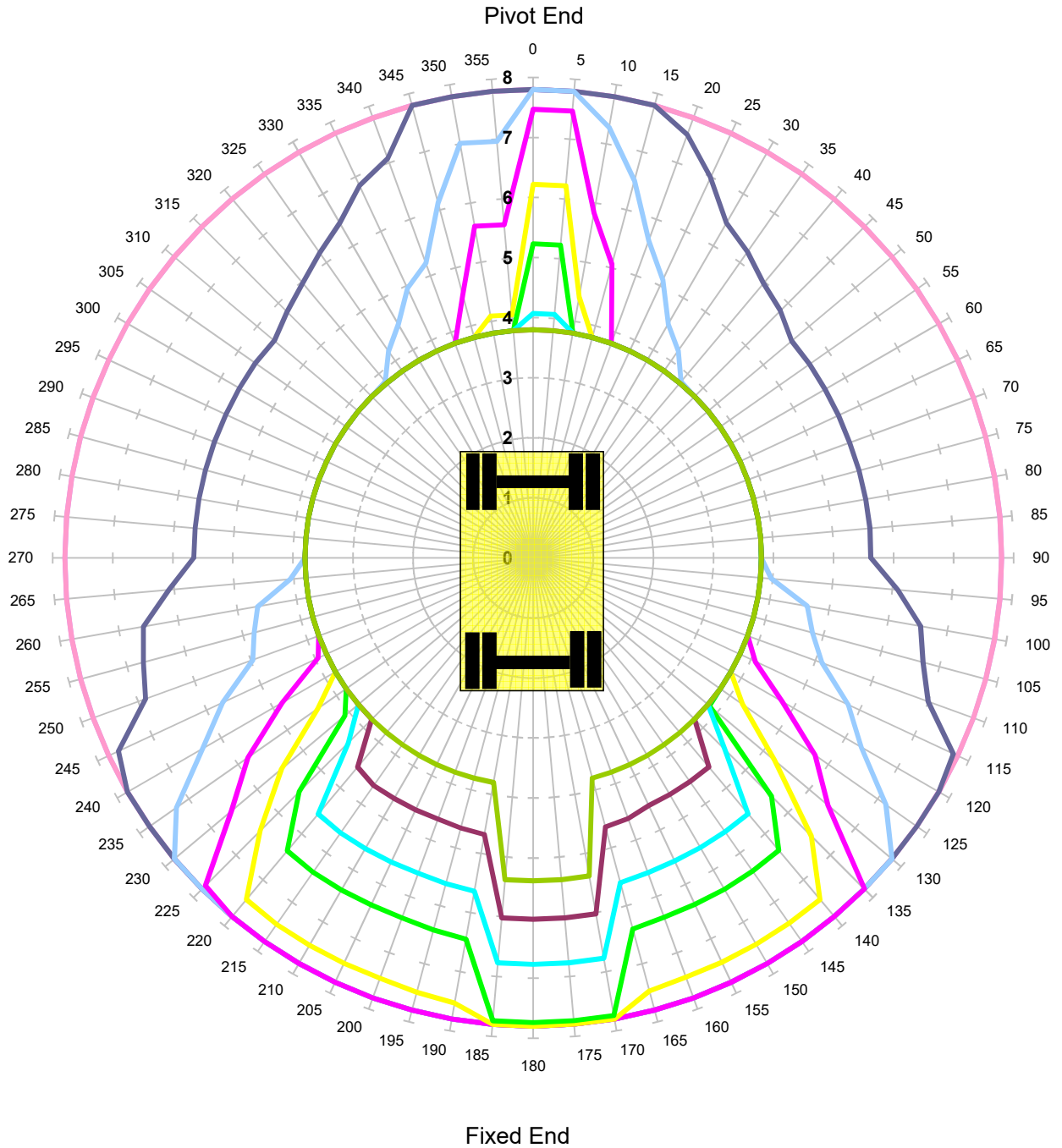

Units in Tonnes

- 1
 — 2
 — 3
 — 4
 — 5
 — 6
 — 7
 — 8
 — 9
 — 10

MACHINE & MODEL:	Colmar T10000FS	REFERENCE:	Dipper Extends by 1000mm
SERIAL No:	8443	DATE OF CHART:	29-May-2019
EQUIPMENT:	4.08m + 2.10m	SAFETY FACTOR:	71.0%
COMMENT:			

Colmar T1000FS

**Max Capacity Contours of Radius(m) Plots 3.1m Dipper Cwt Out
Level Ground Height 2m Lift BP
Locked Road**

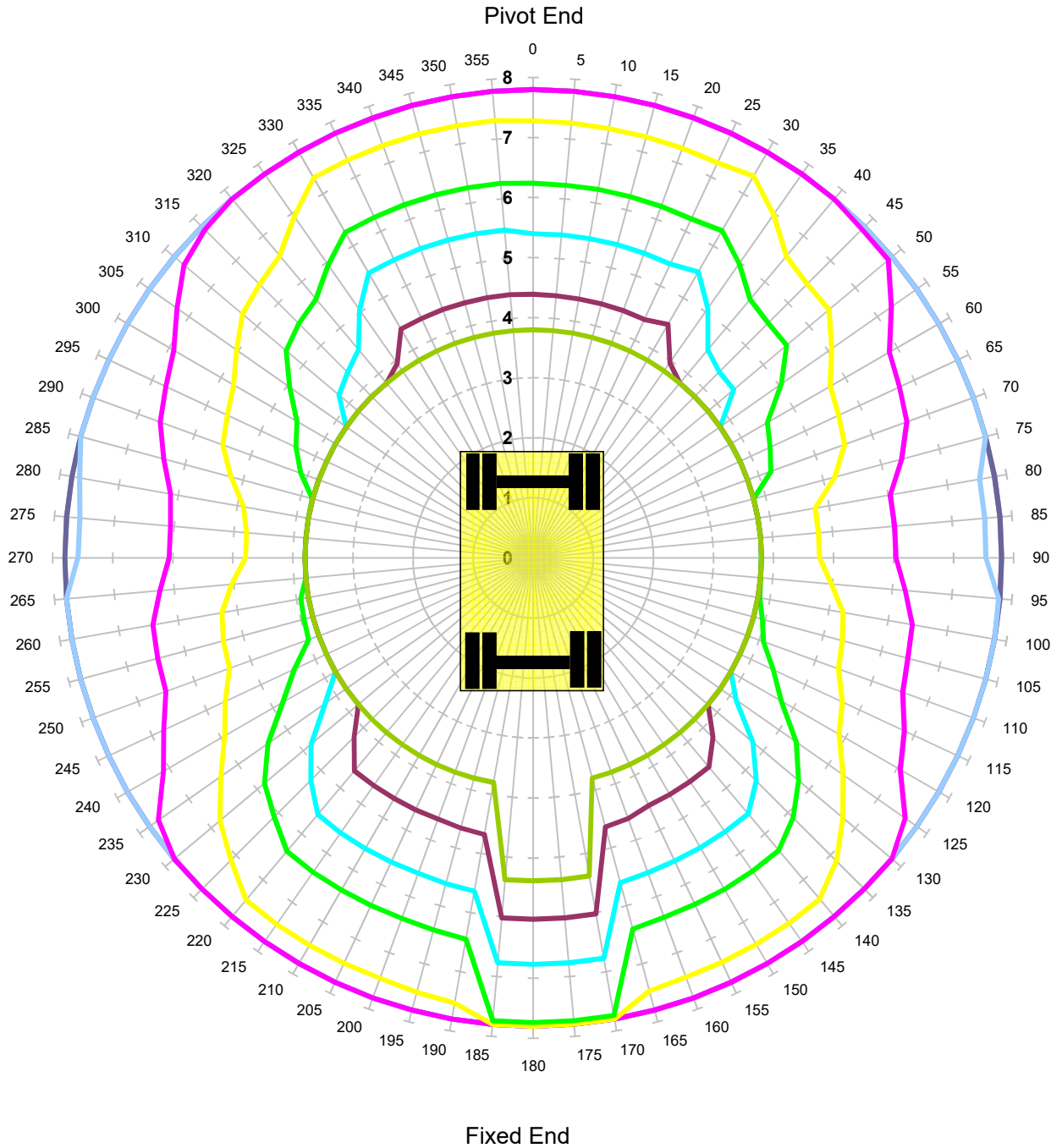

Units in Tonnes

- 1
- 2
- 3
- 4
- 5
- 6
- 7
- 8
- 9
- 10

MACHINE & MODEL:	Colmar T1000FS	REFERENCE:	Dipper Extends by 1000mm
SERIAL No:	8443	DATE OF CHART:	29-May-2019
EQUIPMENT:	4.08m + 2.10m	SAFETY FACTOR:	71.0%
COMMENT:			

Colmar T10000FS

**Max Capacity Contours of Radius(m) Plots 3.1m Dipper Cwt Out
Gradient 1 in -25 Height 2m Lift BP**

Unlocked Rail Cant -150mm - Tandem Lift

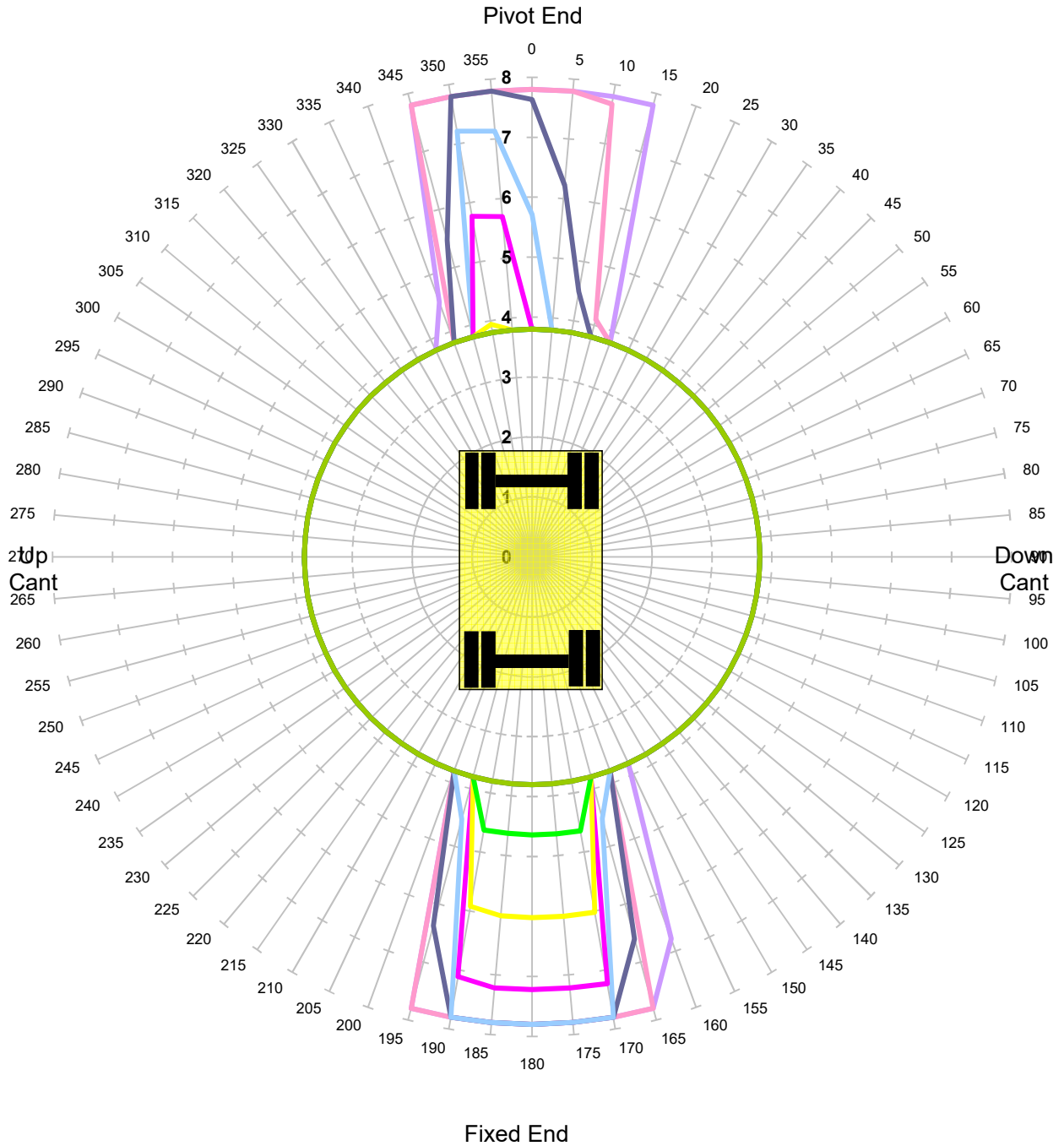

Units in Tonnes

- 1
 — 2
 — 3
 — 4
 — 5
 — 6
 — 7
 — 8
 — 9
 — 10

MACHINE & MODEL:	Colmar T10000FS	REFERENCE:	Dipper Extends by 1000mm
SERIAL No:	8443	DATE OF CHART:	29-May-2019
EQUIPMENT:	4.08m + 2.10m	SAFETY FACTOR:	45.0%
COMMENT:			

Colmar T10000FS

**Max Capacity Contours of Radius(m) Plots 3.1m Dipper Cwt Out
Gradient 1 in -25 Height 2m Lift BP**

Unlocked Rail Cant -50mm - Tandem Lift

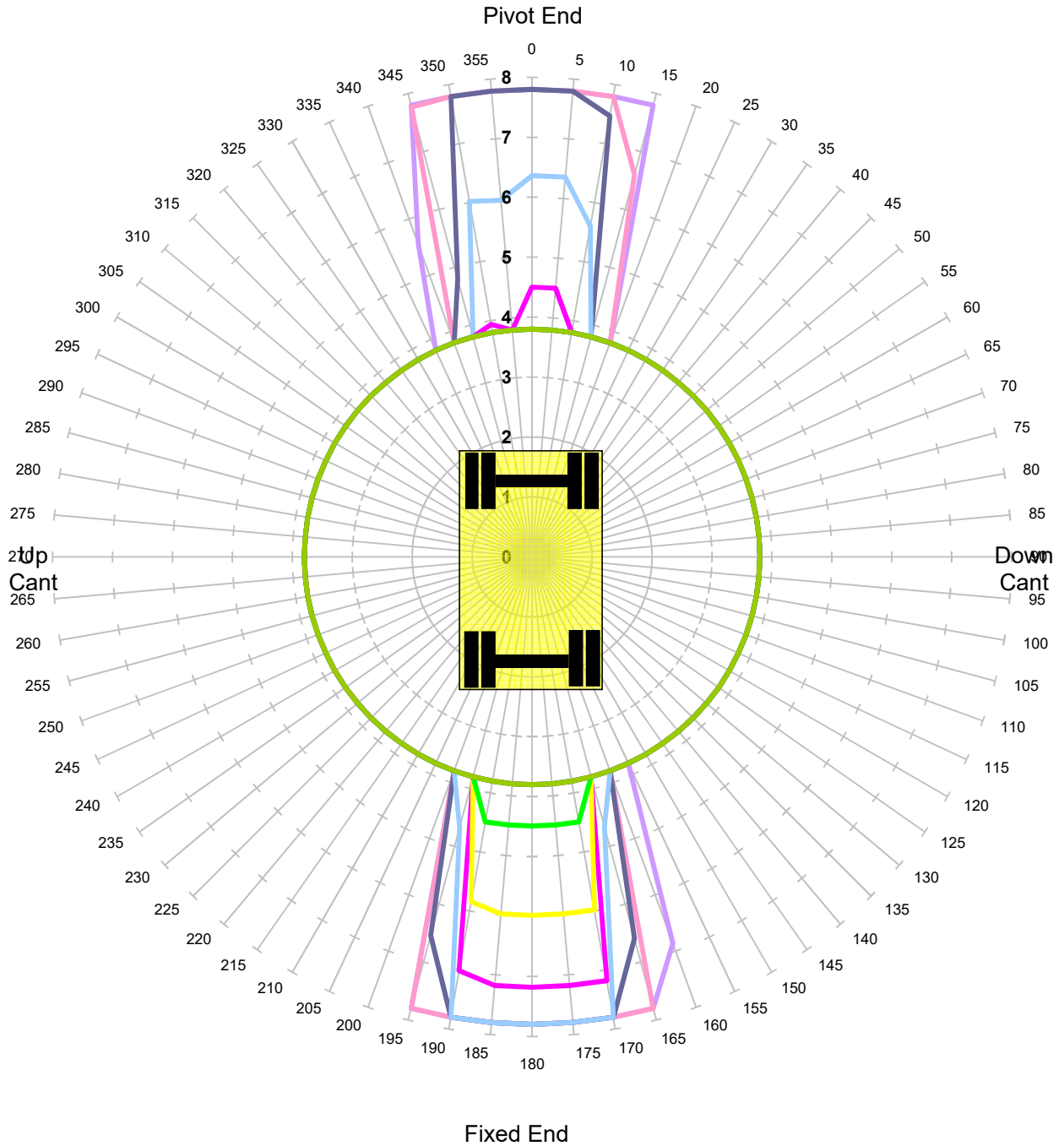

MACHINE & MODEL:	Colmar T10000FS	REFERENCE:	Dipper Extends by 1000mm
SERIAL No:	8443	DATE OF CHART:	29-May-2019
EQUIPMENT:	4.08m + 2.10m	SAFETY FACTOR:	45.0%
COMMENT:			

Colmar T10000FS

**Max Capacity Contours of Radius(m) Plots 3.1m Dipper Cwt Out
Gradient 1 in -25 Height 2m Lift BP**

Unlocked Rail Cant 50mm - Tandem Lift

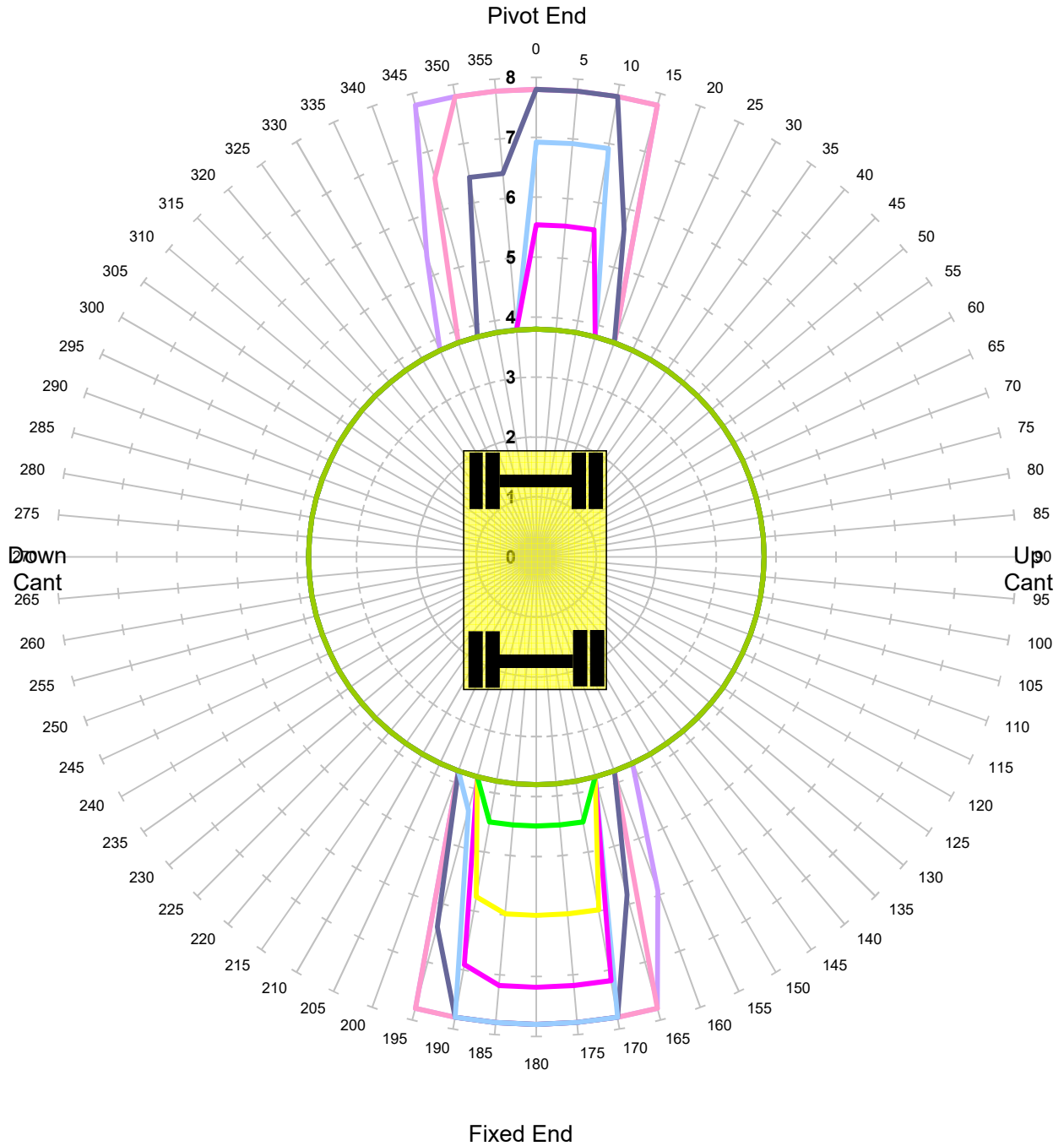

Units in Tonnes

- 1
- 2
- 3
- 4
- 5
- 6
- 7
- 8
- 9
- 10

MACHINE & MODEL:	Colmar T10000FS	REFERENCE:	Dipper Extends by 1000mm
SERIAL No:	8443	DATE OF CHART:	29-May-2019
EQUIPMENT:	4.08m + 2.10m	SAFETY FACTOR:	45.0%
COMMENT:			

Colmar T10000FS

**Max Capacity Contours of Radius(m) Plots 3.1m Dipper Cwt Out
Gradient 1 in -25 Height 2m Lift BP**

Unlocked Rail Cant 150mm - Tandem Lift

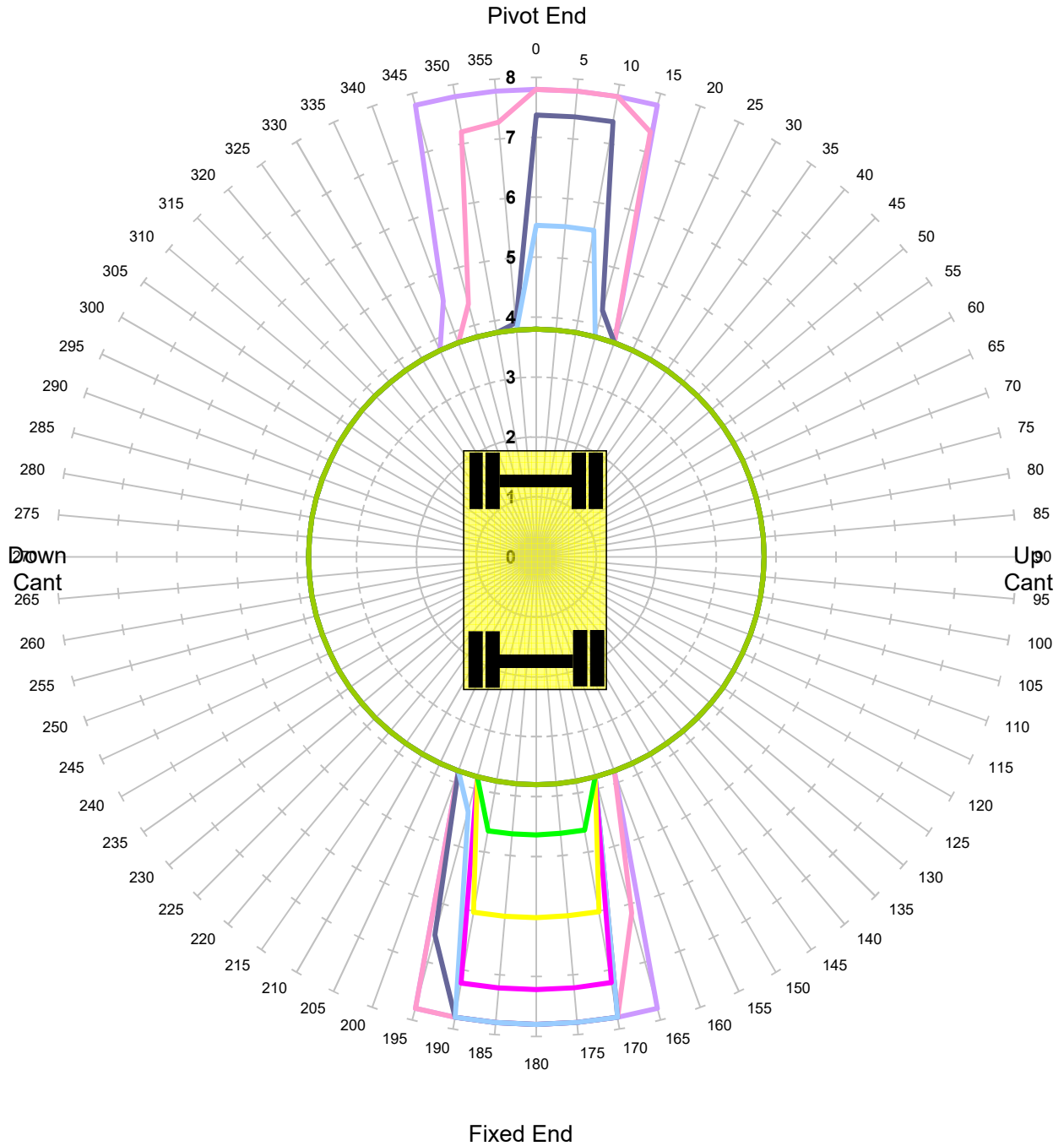

MACHINE & MODEL:	Colmar T10000FS	REFERENCE:	Dipper Extends by 1000mm
SERIAL No:	8443	DATE OF CHART:	29-May-2019
EQUIPMENT:	4.08m + 2.10m	SAFETY FACTOR:	45.0%
COMMENT:			

Colmar T10000FS

**Max Capacity Contours of Radius(m) Plots 3.1m Dipper Cwt Out
Gradient 1 in -25 Height 2m Lift BP**

Locked Rail Cant -150mm - Tandem Lift

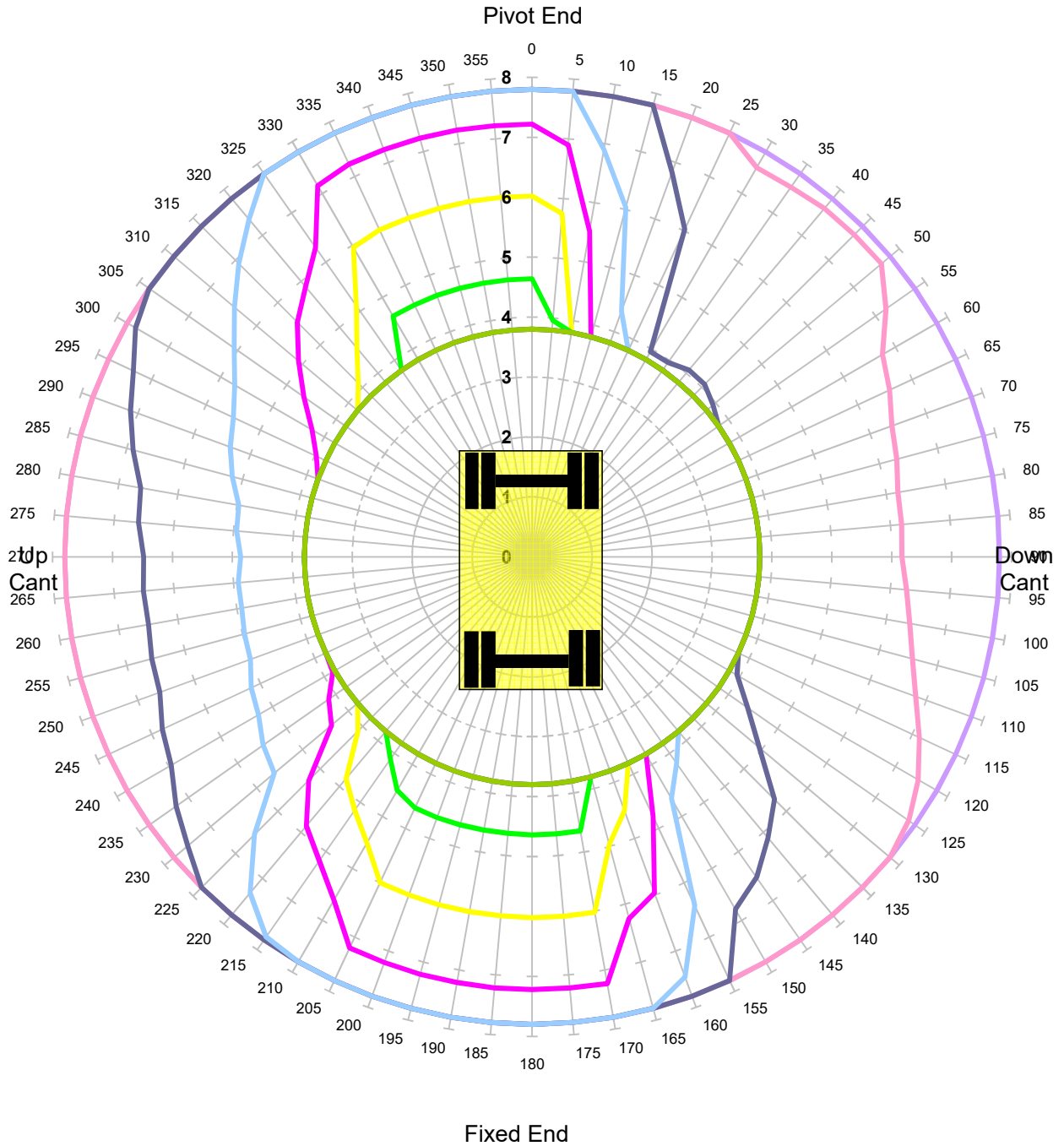

MACHINE & MODEL:	Colmar T10000FS	REFERENCE:	Dipper Extends by 1000mm
SERIAL No:	8443	DATE OF CHART:	29-May-2019
EQUIPMENT:	4.08m + 2.10m	SAFETY FACTOR:	60.0%
COMMENT:			

Colmar T10000FS

**Max Capacity Contours of Radius(m) Plots 3.1m Dipper Cwt Out
Gradient 1 in -25 Height 2m Lift BP
Locked Rail Cant -50mm - Tandem Lift**

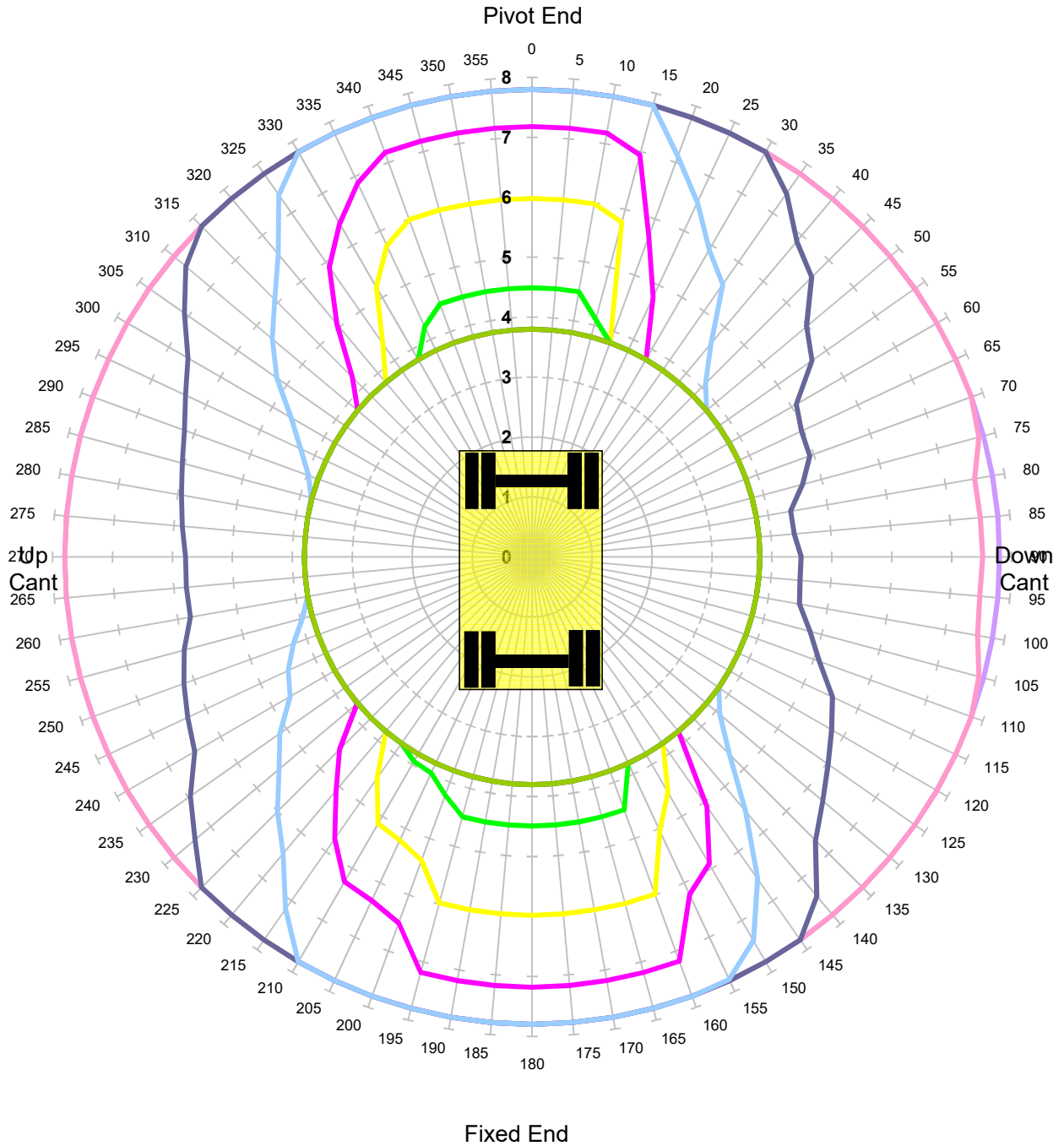

MACHINE & MODEL:	Colmar T10000FS	REFERENCE:	Dipper Extends by 1000mm
SERIAL No:	8443	DATE OF CHART:	29-May-2019
EQUIPMENT:	4.08m + 2.10m	SAFETY FACTOR:	60.0%
COMMENT:			

Colmar T10000FS

**Max Capacity Contours of Radius(m) Plots 3.1m Dipper Cwt Out
Gradient 1 in -25 Height 2m Lift BP
Locked Rail Cant 50mm - Tandem Lift**

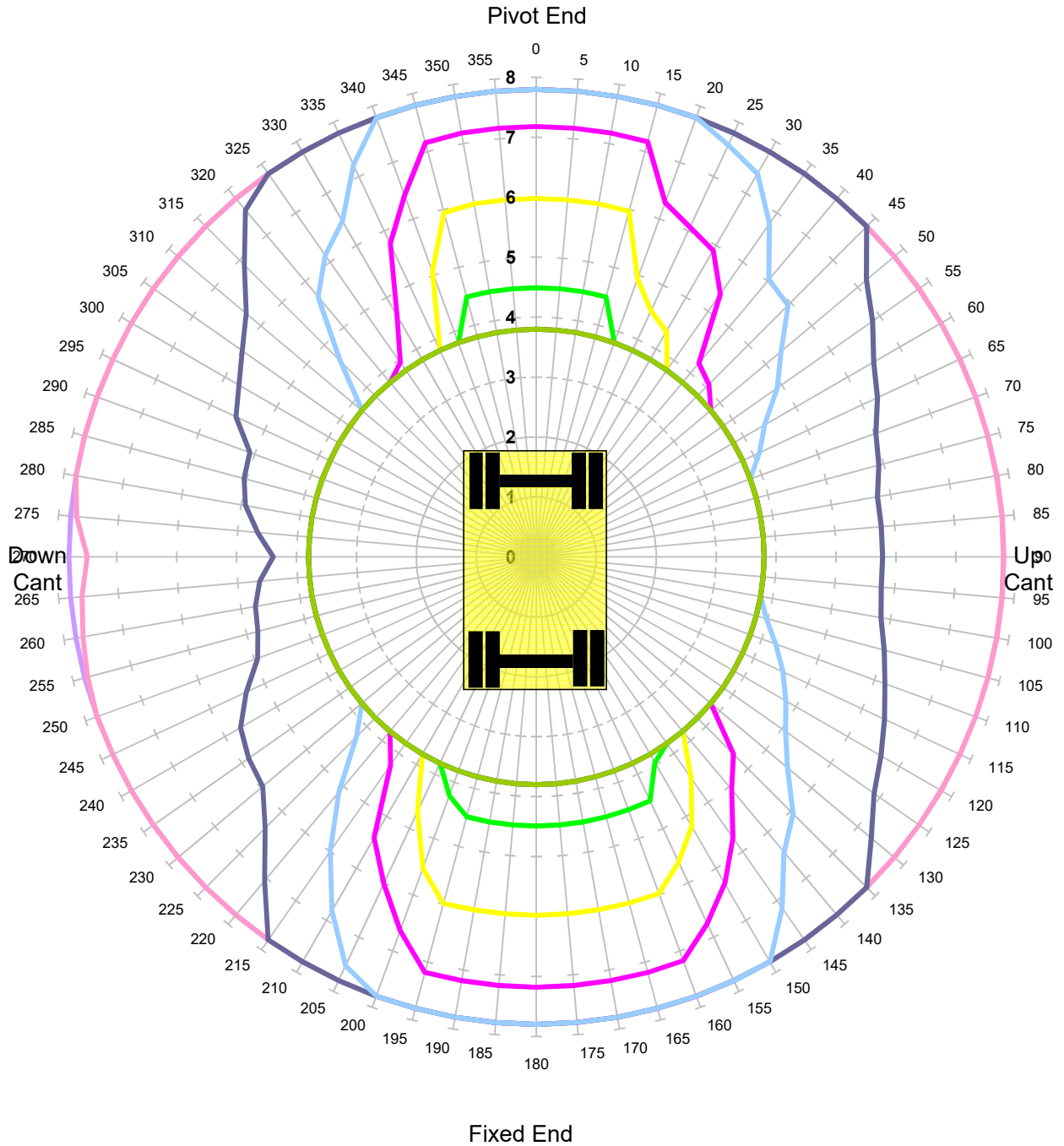

Units in Tonnes

- 1
 — 2
 — 3
 — 4
 — 5
 — 6
 — 7
 — 8
 — 9
 — 10

MACHINE & MODEL:	Colmar T10000FS	REFERENCE:	Dipper Extends by 1000mm
SERIAL No:	8443	DATE OF CHART:	29-May-2019
EQUIPMENT:	4.08m + 2.10m	SAFETY FACTOR:	60.0%
COMMENT:			

Colmar T10000FS

**Max Capacity Contours of Radius(m) Plots 3.1m Dipper Cwt Out
Gradient 1 in -25 Height 2m Lift BP
Locked Rail Cant 150mm - Tandem Lift**

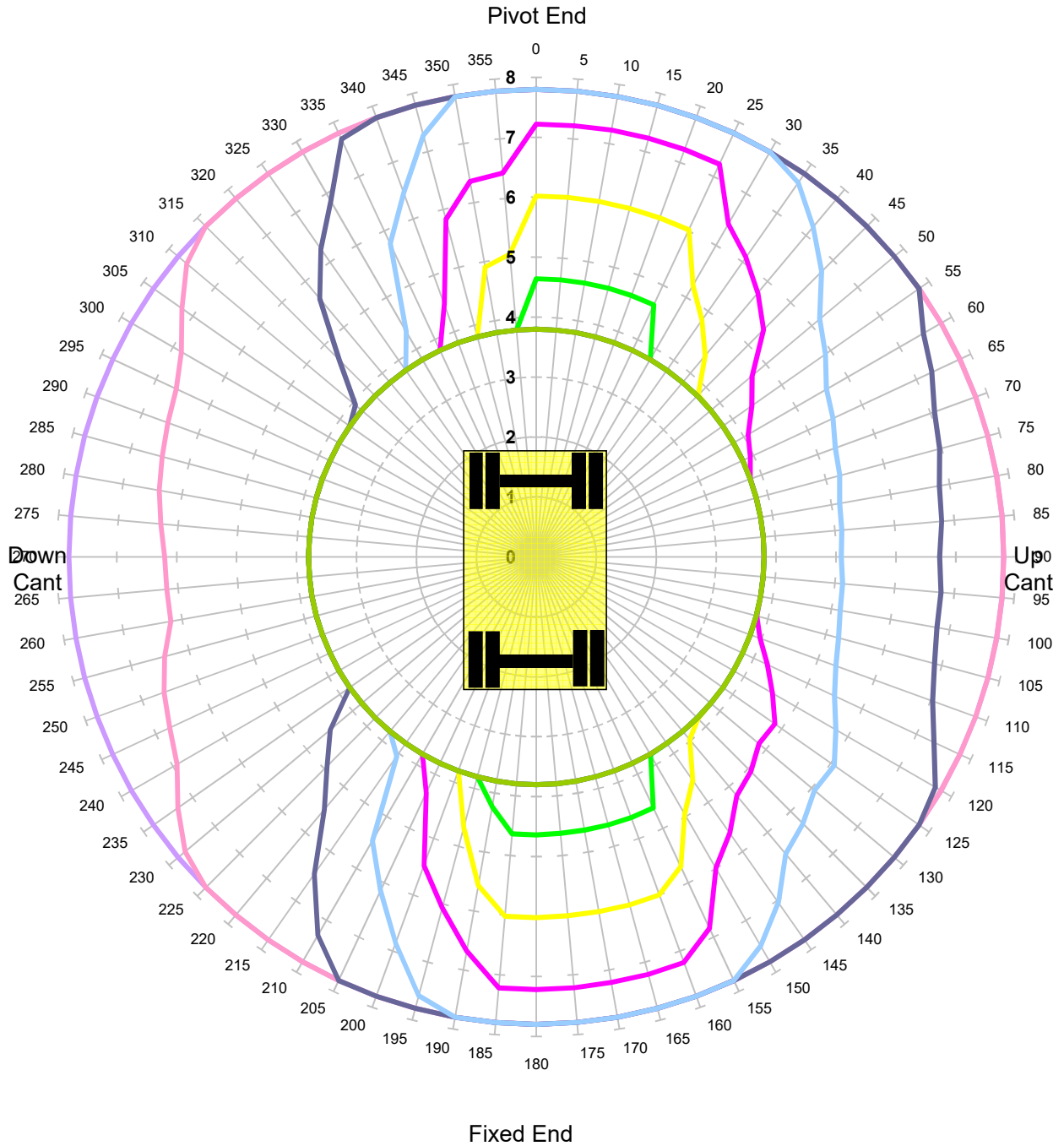

MACHINE & MODEL:	Colmar T10000FS	REFERENCE:	Dipper Extends by 1000mm
SERIAL No:	8443	DATE OF CHART:	29-May-2019
EQUIPMENT:	4.08m + 2.10m	SAFETY FACTOR:	60.0%
COMMENT:			

Colmar T1000FS
Max Capacity Contours of Radius(m) Plots 3.1m Dipper Cwt Out
Level Ground Height 2m Lift BP
Unlocked Road - Tandem Lift

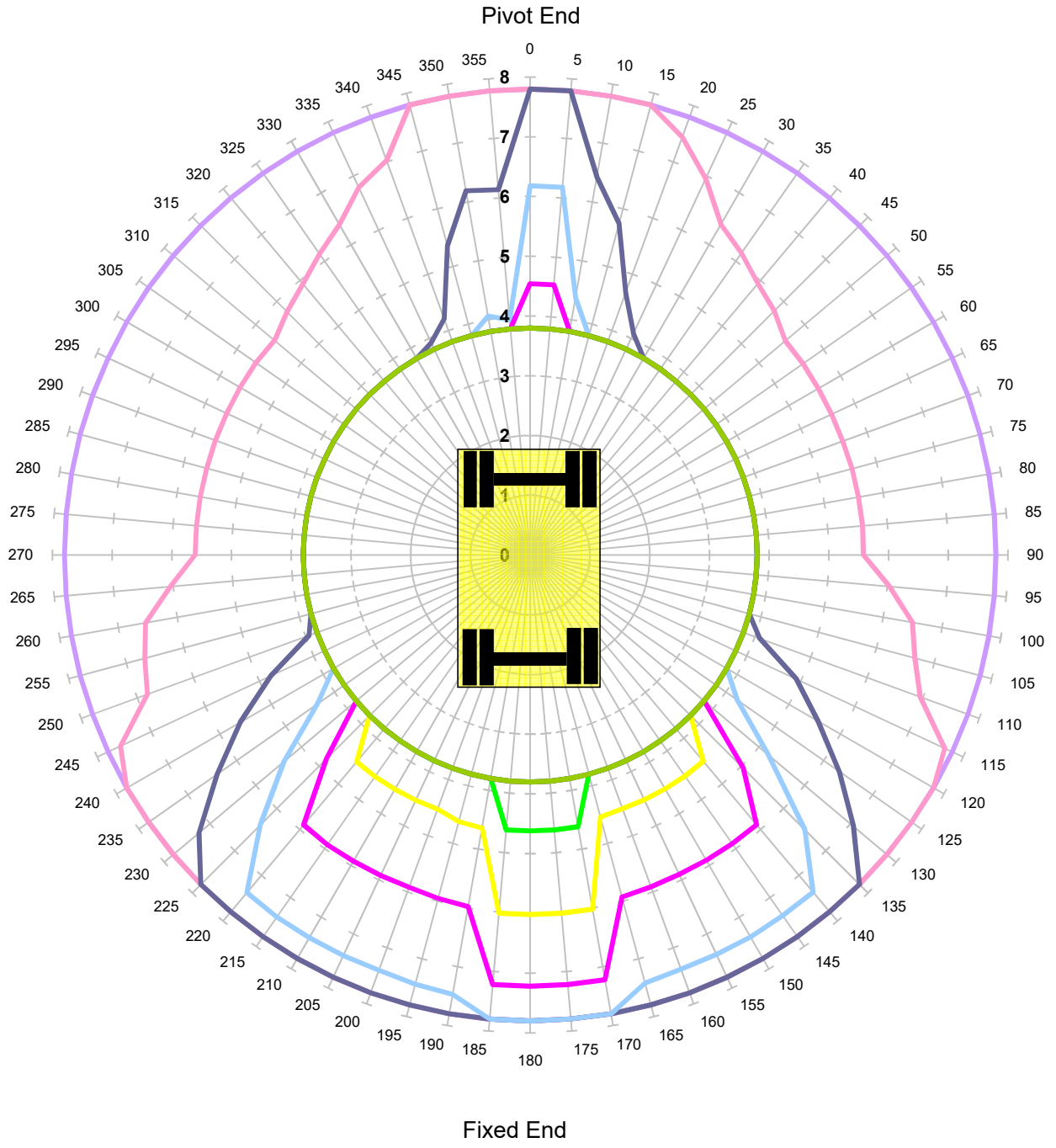

Units in Tonnes

- 1
- 2
- 3
- 4
- 5
- 6
- 7
- 8
- 9
- 10

MACHINE & MODEL:	Colmar T1000FS	REFERENCE:	Dipper Extends by 1000mm
SERIAL No:	8443	DATE OF CHART:	29-May-2019
EQUIPMENT:	4.08m + 2.10m	SAFETY FACTOR:	47.0%
COMMENT:			

Colmar T10000FS
Max Capacity Contours of Radius(m) Plots 3.1m Dipper Cwt Out
Level Ground Height 2m Lift BP
Locked Road - Tandem Lift

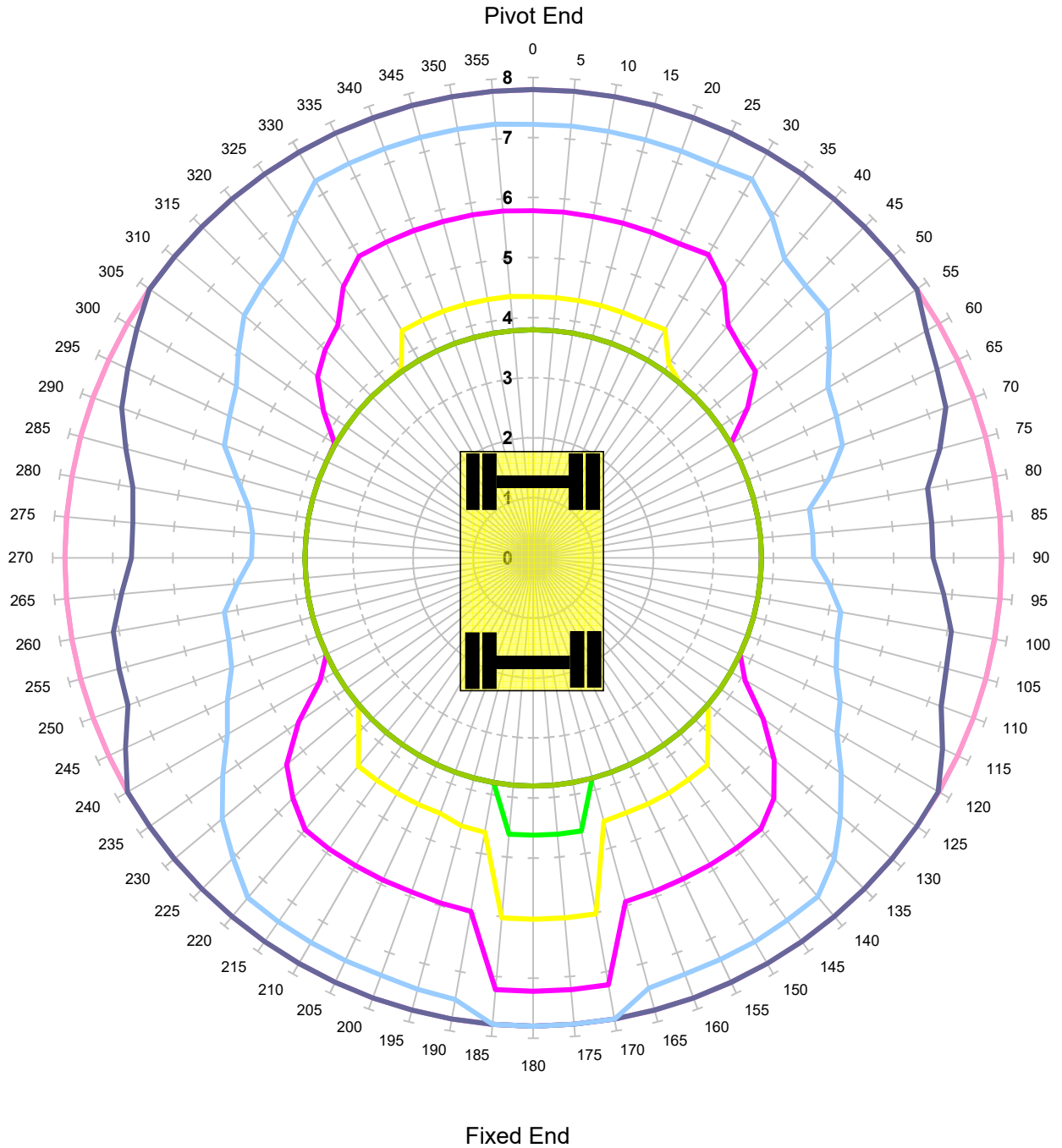

Units in Tonnes

- 1
- 2
- 3
- 4
- 5
- 6
- 7
- 8
- 9
- 10

MACHINE & MODEL:	Colmar T10000FS	REFERENCE:	Dipper Extends by 1000mm
SERIAL No:	8443	DATE OF CHART:	29-May-2019
EQUIPMENT:	4.08m + 2.10m	SAFETY FACTOR:	47.0%
COMMENT:			